

User Guide

# Davit Fall Arrest System

---

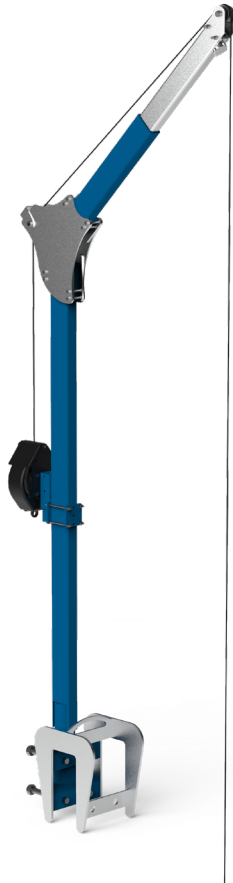

## Product Information

### **Overview**

---

A simple, robust, removable cantilevered fall arrest system designed to be fitted to trench shoring systems, including trench box systems and large trench sheets.

The system provides a suitable means of rescue for those working in trenches and confined places.

The system comprises of a Davit Clamp, a two-part Davit arm, a Fall Arrest Recovery Device and the relevant brackets to hold the recovery device in place.

### **Key Benefits**

- Provides a suitable means of rescue which satisfies the requirement of the Confined Spaces Regulation (1997).
- Lightweight and durable.
- Fall Arrest Recovery Device has a 15-metre galvanised steel cable on the pulley.

## Product Information Specification

Item	Product Code
Davit Fall Arrest System	PE136

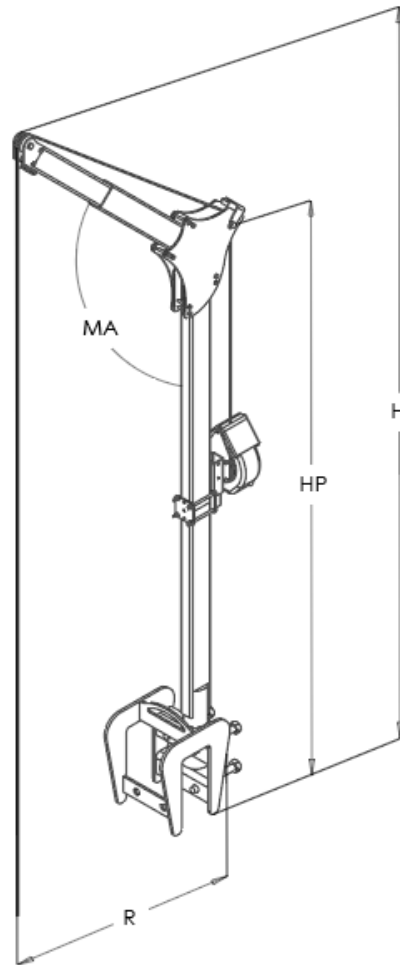

<sup>1</sup>Working Load Limit

Max Height	Min Height	Height to Pivot	Max Reach	Min Reach	Max Angle	Throat Width	Weight	WLL <sup>1</sup>
3023mm	2794mm	2235mm	737mm	495mm	135°	5 - 131mm	60kg	150kg

## Product Information Parts Diagram

### Davit Fall Arrest System

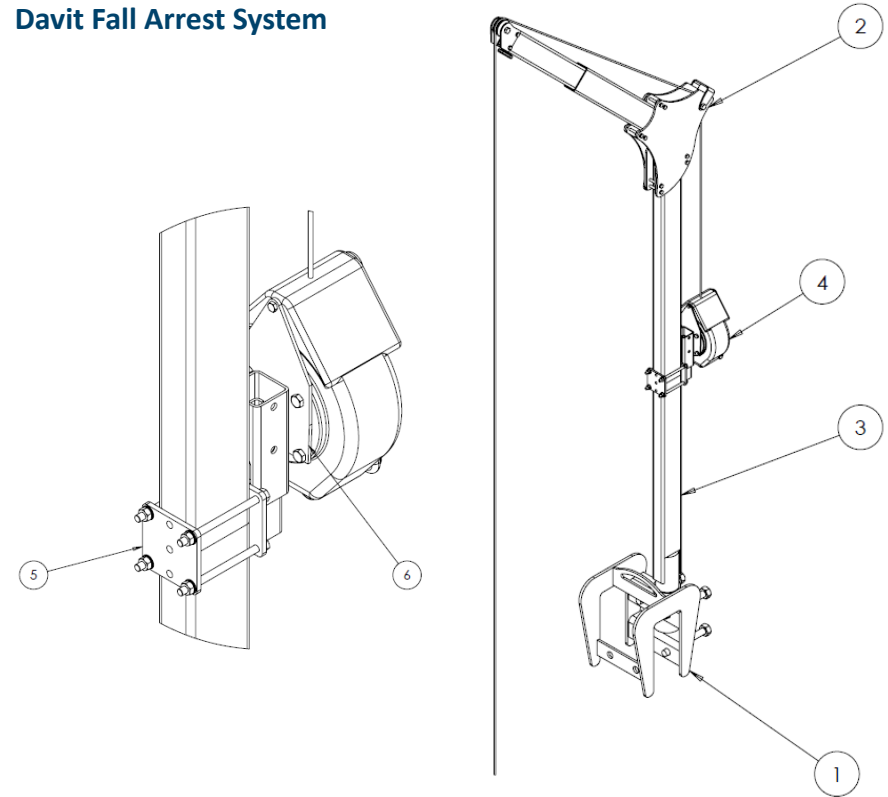

NOTE: These parts are for this model, they may differ for previous versions. Please contact Conquip with any queries.

Item Number	Part Number	Description	Quantity
1	PE130	Barrel Mount Base	1
2	PE131	Upper Davit	1
3	PE132	Lower Davit	1
4	PE133	Fall Arrest Recovery Device	1
5	PE134	Winch to Davit Bracket	1
6	PE135	Torq to Davit Bracket	1

## Original Working Instructions

# Usage Instructions

---

### Important Usage Notes

- The system is only designed for emergency use, lifting a single person in a harness. It is not designed for lifting tools or equipment.
- The winch has a 15-metre length of steel cable, do not use if you are working at a greater distance than 15 metres from the davit arm.
- If a fall happens and the fall arrest winch is activated, the winch should be removed from service or inspected in accordance with manufacturer's instructions.
- Assembly to be carried out by a competent person.

### Assembly Instructions

1. Install the base clamp, ideally next to the excavation access point.
2. Lower the clamp jaw over the sheet or box panel before clamping in place using 4 bolts. The barrel mount on the clamp should be on the outside of the excavation.
3. The integrated spanners allow the davit clamp bolts to be tightened without the need for any other tools. Check the clamp is level and properly secured.
4. Once fixed in position, check that the clamp is level and properly secured.
5. Insert the lower davit piece into the awaiting clamp. The lower davit section is already fitted with the winch connector.
6. Fit the Fall Arrest Recovery Winch to the winch connector and check it is fitted securely. Prior to use the winch should be examined for any sign of damage or wear and tear. Check the locking mechanism by pulling sharply and firmly on the winch.
7. Insert the upper davit arm into the lower davit arm. It slots in with no need for any extra pins.
8. To extend the Davit arm use the adjuster on the lower side of the upper arm. Undo the mechanism and simply extend. Then secure in place once at the desired length.
9. Once all the components are assembled feed the winch wire through both the integrated pulleys on the upper davit arm.
10. The unit must now be inspected and signed off as fit for use.

## Original Working Instructions

# Usage Instructions

---

### Usage Instructions

1. Fix the winch to a compatible harness before entering an excavation, such as a standard harness, so that it can be used as a fall arrest.
2. Enter the excavation. If in the case of a fall the winch mechanism will lock and prevent the operative from falling.
3. To safely retract the operative from the excavation other site personnel must lift and lower by manually operating the winch lever.

# Original Working Instructions

## Safety Instructions

### Basic Safety

A site-specific Risk Assessment, and lift plan where applicable, must be completed by the responsible person before using this equipment to control risks, produce a safe system of work and ensure safety for you, your colleagues and others. Your risk assessment will determine the correct Personal Protective Equipment (PPE) for the task you are doing. You must use it. Conquip recommends that you should wear:

- Suitable clothing
- Gloves
- Hard hat
- Protective footwear (steel toecaps)
- Safety glasses



### Important Safety Notes

- Read these instructions before using this equipment. If there is anything you do not understand or if you have any concerns do not use this equipment. Contact your supervisor or Conquip Engineering Group for advice.
- You must check that you have considered all the safety requirements for the task you are doing and that this equipment is suitable.
- You must protect bystanders and the general public by preventing access to the working area.
- Do not use this equipment if you are tired, unwell or under the influence of alcohol or drugs. If you are taking any medicine or undergoing treatment you should inform your supervisor.

### Usage & Transportation

- Never unevenly load this equipment.
- The weight of the equipment, together with its attachments, must be added to the weight of the load when calculating the total load that will be imposed on the lifting apparatus / operating machine.
- This equipment must be used in conjunction with the load ratings of the lifting apparatus / operating machine. (Refer to the manufacturers' load ratings and original working instructions).
- Make sure you know how to use this equipment and understand all aspects of its operation in case of emergency.
- This equipment weighs more than 25kg. Do not lift or manhandle without machine assistance.
- Do not operate this equipment near overhead power lines.
- Take care in confined spaces, near ceilings or similar hazards. This equipment was designed for vertical lifting. Do not drag, or swing.
- Before operating this equipment, check that you have enough space for you to work safely and make sure that the working area is clear of hazards, obstructions and personnel.
- Before lowering equipment make sure that the landing zone is clear and capable of accepting the size and weight of the load.
- Crush Risk. Keep hands and feet clear of the equipment at all times to avoid injury.
- Do not exceed the maximum Working Load Limit (WLL) shown on the serial plate. Ensure that the WLL on the individual lift points is not exceeded.

### Personnel

- All personnel must wear relevant personal protective equipment.
- Do not wear loose clothing or jewellery and tie back long hair to avoid becoming tangled or trapped in this equipment. You must make everyone in the work area aware of what you are doing.
- All personnel involved in the lifting operation must be competent to do so and must have been briefed in conjunction with this User Guide available from Conquip Engineering Group, the manufacturer.

### Equipment Maintenance & Cleaning

- It is mandatory that the equipment is thoroughly examined regularly, by a qualified engineer, to ensure compliance with relevant regulation/s.
- This product may incorporate various loose and detachable items of lifting gear. Refer to the separate requirements for the safe use of those items.
- When not being used, store the unit in a clean, upright condition and in a safe place where it will be protected from thieves and unauthorised users.
- This equipment must be inspected by the responsible person before each use and then regularly, as determined by your risk assessment or working practice. If you have any concerns about condition or suitability do not use.

## Disclaimer

### Warranty

The products supplied by Conquip Engineering Group are all guaranteed by a 12 month warranty.

Apart from where exceptions apply, Conquip Engineering Group promises to repair or replace any fault which the Company considers to be due to defective material or workmanship within 12 months of the date of sale, at no additional cost.

- Faults arising from unauthorised alterations (see modifications section below for full details).
- Damage caused by abuse, neglect, misuse or falling.
- Damage caused because of failure to follow transportation, storage, loading, cleaning or operating instructions.
- Replacement or repair of components due to fair wear and tear.
- Any consequential damage or wear arising from the use or fitting of additional or non-standard parts.

### Modifications

If any third-party modifications or alterations, involving drilling, welding, cutting or distortion of materials in any form, are to be carried out on the product, Conquip Engineering Group must provide full written approval prior to the work being carried out.

Alterations, modifications, additions or repairs must be carried out by Conquip Engineering Group's recognised distributors, if they are not carrying out the work themselves.

Conquip Engineering Group operate a continuous improvement policy and therefore reserve the right to alter technical specifications and user guide details at any point without notice.

Conquip Engineering Group will not cover or reimburse any transportation and/or shipment costs to and from their premises or their recognised agents, or any material and/or labour costs for repair, replacement or assessment against a warranty claim.

Conquip Engineering Group and/or their directors, employees, insurers or recognised agents will not be held liable for consequential damages, losses or expenses relating to the inability to use the product correctly for its purpose.

## EC Declaration of Conformity

### In accordance with EN ISO 17050-1:2004

Declaration: As defined by the Machinery Directive 2006/42/EC and subsequent amendments

We, CONQUIP ENGINEERING GROUP, herewith declare that the following indicated equipment meets the fundamental health and safety requirements concerning the EU guide line(s), due to their design and manufacture.

This declaration will be rendered null and void if the machine is changed without our approval.

Signed:



Dated: 2020

Garry Critchley, Managing Director

<b>Product Code(s):</b>	PE136
<b>EC Directive/Regulation:</b>	2006/42/EC, Lifting Operations and Lifting Equipment Regulations 1998 Provision and Use of Work Equipment Regulations 1998
<b>Harmonised Standards:</b>	BS EN ISO 12100:2010 BS EN 13155
<b>General Description/Designation:</b>	Davit Fall Arrest System – PE136
<b>WLL:</b>	PE136- 150kg

## Important Notes

- This User Guide is for this Conquip product only.
- Any movements of the product must be thoroughly planned before the work commences to identify potential hazards and assess risk.
- All personnel involved in lifting and transportation of this product must have read this User Guide and must be properly briefed.
- You must be competent, alert and medically fit when using this equipment. If you have a medical condition, a mental or physical disability, you must seek advice from a medical professional before using this equipment.

Talking to us is easy

**We're here to help**

Call us on 0845 520 1101

Email us at [sales@cqegroup.com](mailto:sales@cqegroup.com)

[www.cqegroup.com](http://www.cqegroup.com)

**Conquip Engineering Group**

Waterbrook Estate, Alton, Hampshire, GU34 2UD