

User Guide

Access Cage



Product Information Specification

Item	Product Code
1 Person Access Cage	CA126-00120
2 Person Access Cage	CA120AB-00240
4 Person Access Cage	CA123-00480
6 Person Access Cage	CA123-00720
12 Person Access Cage	CA123-01440

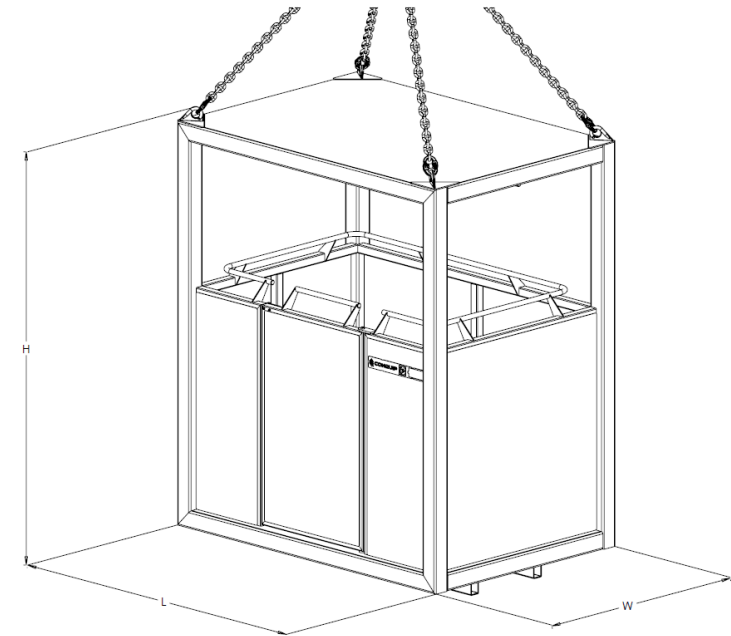

¹Working Load Limit

Product Code	Height	Width	Length	Weight	WLL ¹
CA126-00120	2300mm	700mm	700mm	170kg	120kg
CA120AB-00240	2210mm	1200mm	1450mm	400kg	240kg
CA123-00480	2500mm	1500mm	1450mm	590kg	480kg
CA123-00720	2550mm	1400mm	2000mm	730kg	720kg
CA123-01440	2550mm	2700mm	2000mm	1100kg	1440kg

Product Information Overview

The Conquip Access Cage are used to transport personnel around site, often used to reach confined spaces or to provide access to tunnels and shafts.

Manufactured to the highest standards, as relevant.

Key Benefits

- Wide range of sizes, from 1 person capacity to 12 person.
- Suitable for different applications, from personnel movement to access for working in a confined space.
- Manufactured with half height solid steel sides for maximum safety as well as offering good visibility for machine operator and personnel in the cage.
- Internal harness attachment points.
- Safety locking catch for secure door closure.

Product Information Parts Diagram

1 Person Access Cage

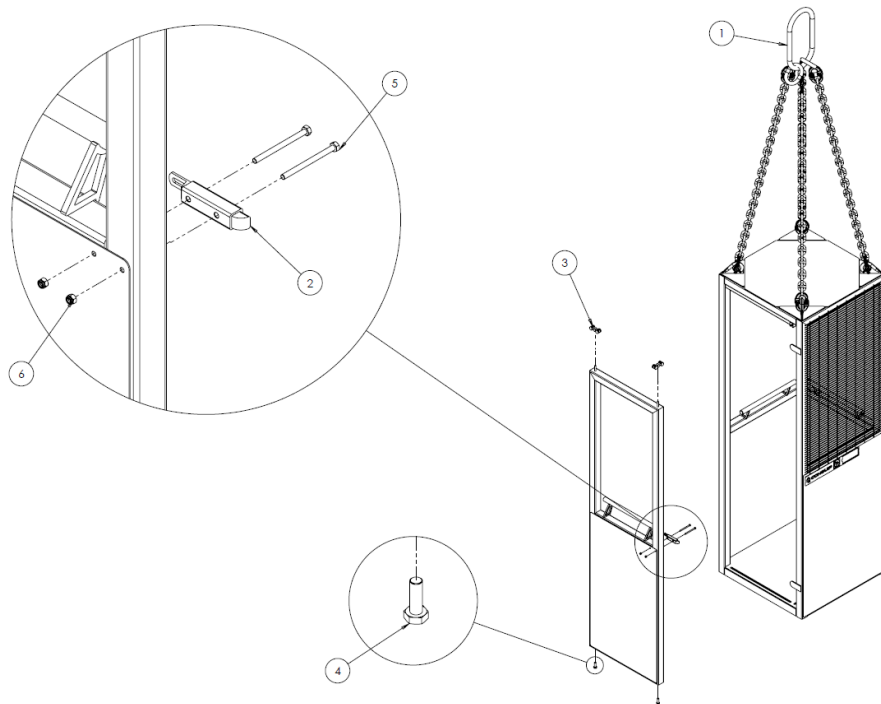

NOTE: These parts are for this model, they may differ for previous versions. Please contact Conquip with any queries.

Item Number	Part Number	Description	Quantity
1	CF1.5-8-6ZX8	Chain Assembly	1
2	ZZ170001	End Slam Locking Catch	1
3	ZZ960011	Sliding Door Hanger 4 Wheel	2
4	NS800666	M10 x 30 Hex Head Set Screw	2
5	NS800840	M6 x 80 Hex Head Set Screw	2
6	NS800826	M6 Nyloc Nut	2

Product Information Parts Diagram

2 Person Access Cage

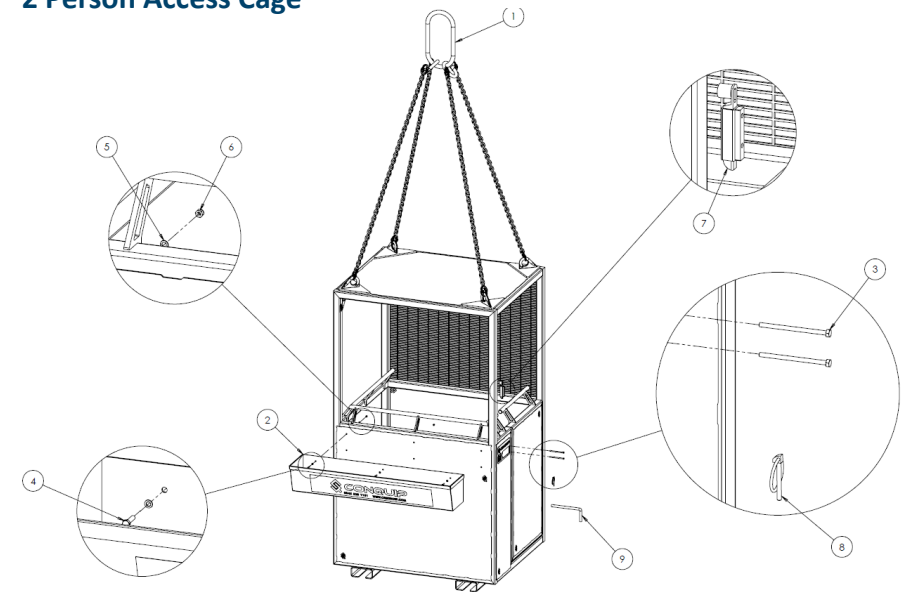

NOTE: These parts are for this model, they may differ for previous versions. Please contact Conquip with any queries.

Item Number	Part Number	Description	Quantity
1	CF1.5-10-4ZX8	Chain Assembly	1
2	CA120AB-00240-02	Cage Tray	1
3	NS800903	M6 x 100 Hex Head Set Screw	2
4	NS800881	M6 x 20 Hex Head Set Screw	6
5	NS800737	M6 Washer	12
6	NS800826	M6 Nyloc Nut	8
7	ZZ170001	End Slam Locking Catch	1
8	ZZ990009	6mm Linch Pin	2
9	ZZ990000	16mm Heel Pin	2

Product Information
Parts Diagram

4 Person Access Cage

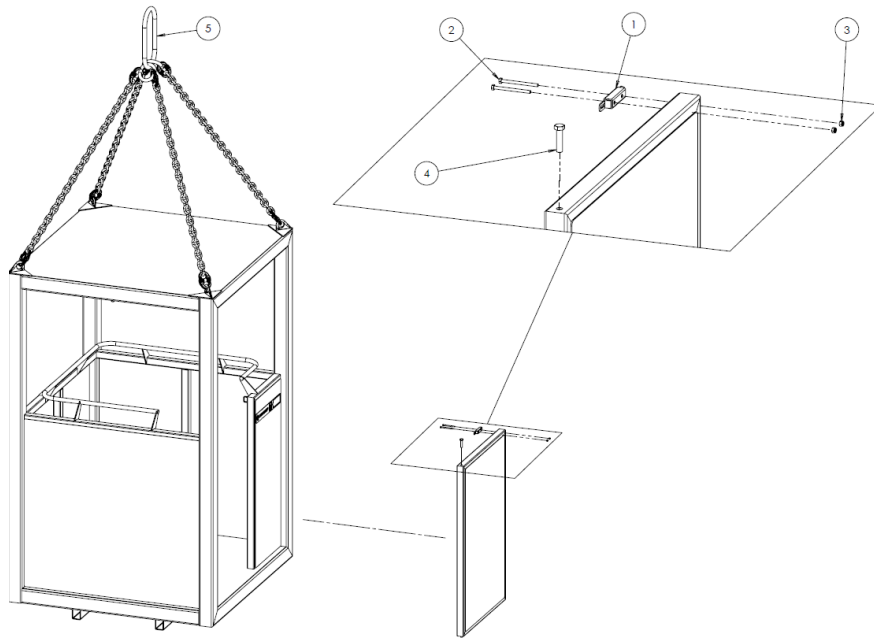

NOTE: These parts are for this model, they may differ for previous versions. Please contact Conquip with any queries.

Item Number	Part Number	Description	Quantity
1	ZZ170001	End Slam Locking Catch	1
2	NS800840	M6 x 80 Hex Head Set Screw	2
3	NS800826	M6 Nyloc Nut	2
4	NS800817	M12 x 50 Hex Head Set Screw	1
5	CF1.5-13-4ZX8	Chain Assembly	1

Product Information
Parts Diagram

6 Person Access Cage

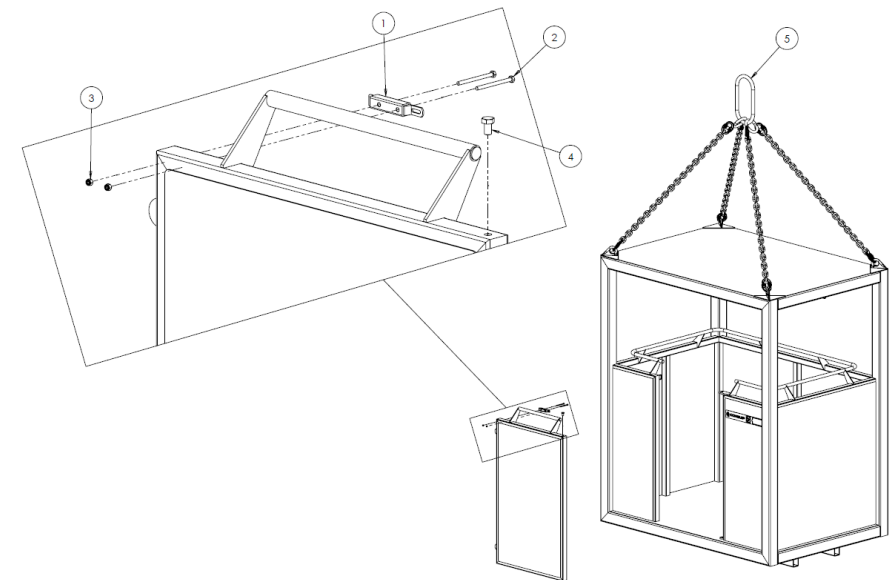

NOTE: These parts are for this model, they may differ for previous versions. Please contact Conquip with any queries.

Item Number	Part Number	Description	Quantity
1	ZZ170001	End Slam Locking Catch	1
2	NS800840	M6 x 80 Hex Head Set Screw	1
3	NS800826	M6 Nyloc Nut	2
4	NS800817	M12 x 50 Hex Head Set Screw	2
5	CF-2.1-13-4ZX8	Chain Assembly	1

12 Person Access Cage

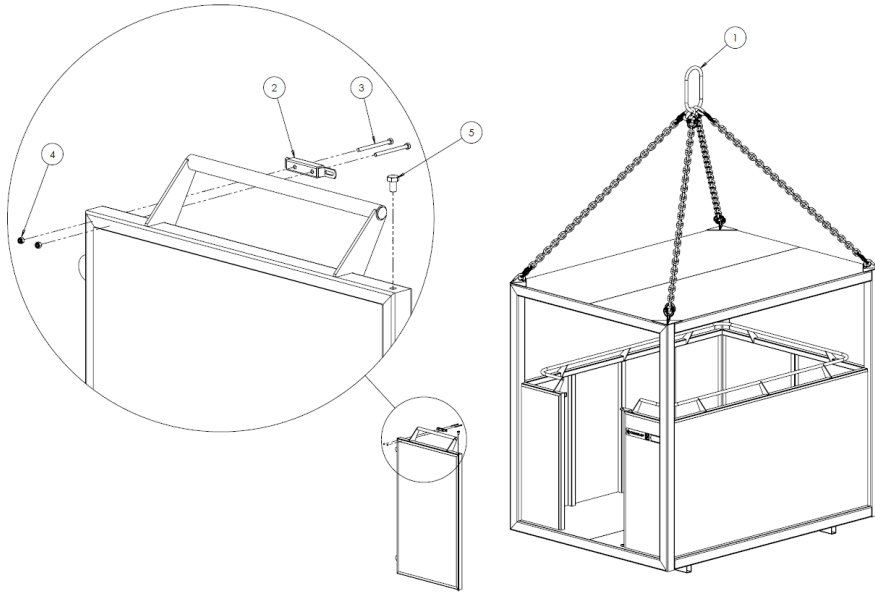

NOTE: These parts are for this model, they may differ for previous versions. Please contact Conquip with any queries.

Item Number	Part Number	Description	Quantity
1	CF2.4-16-4ZX1	Chain Assembly	1
2	ZZ170001	End Slam Locking Catch	1
3	NS800840	M6 x 80 Hex Head Set Screw	2
4	NS800826	M6 Nylloc Nut	2
5	NS800817	M12 x 50 Hex Head Set Screw	1

Important Usage Notes

- Each cage has been designed for a certain amount of people – refer to the specification details.
- Do not overload by volume or weight.
- Do not lean from the cage.
- Do not stand on the guardrails or place materials on platforms guardrails.
- Do not use boxes, steps or similar to gain extra height.
- Make sure all tools are tethered to relevant personnel or handrails.
- Do not use in high winds, storms, ice, snow, fog, sleet or other adverse weather conditions.
- Do not operate with other machinery simultaneously.
- Guide ropes and anchors should be used to prevent unintended movement.
- Comply with harness manufacturer’s usage instructions.

Using with a Forklift (2 Person Cages only)

1. To attach the Access Cage to a forklift, first release the heel pin by removing the linch pin and pulling from the attachment. Set the machine’s forks to the correct width for the Access Cage’s fork pockets. Make sure that they are equidistant from the centre.
2. Drive the forklift to the Access Cage aligning the forks with the Access Cage fork pockets.
3. Double check that all is correctly aligned, then move the forklift forward until the forks are fully inserted into the fork pockets.
4. Apply the park brake and switch off the forklift engine.
5. Insert the heel pin ensuring it passes behind the heel of the fork, use the linch pin to lock the heel pin in place. The Access Cage is now ready for use.
6. While the cage is elevated the forklift operator must remain at the controls and the forklift must not be capable of movement, including tilt or side shift and chassis or mast levelling. The cage is not suitable for use on variable reach trucks that can lift to a nominal height greater than 6 metres, in accordance with PM28 fourth edition.
7. See steps 2- 10 on the next page for instructions on how to use the cage.

Original Working Instructions Usage Instructions

Using with a Crane and Chain Sling

1. Attach the lifting apparatus' hook to the Access Cage's certified four leg lifting chain. Always ensure that the hook's gate is correctly closed.
2. Personnel should enter the cage only when fully lowered.
3. Open the entry gate, enter the cage, then close and the self latching gate. Do not allow more people to enter the cage than it has been designed for.
4. When wearing a harness and restraint lanyard, attach the lanyard from the harness to the anchorage point. Ensure the length of the lanyard restricts access from the cage.
5. Carefully raise the cage just off the ground and check for balance and security.
6. Carefully transport the cage to its required destination, taking care not to jolt the load.
7. When in position, the cage can be lowered onto firm, level ground.
8. Having lowered the platform to the ground, exit and close the gate behind you. Do not exit the platform unless at ground level. Do not exit unless the cage is stationary and stable.

1 Person Cage Harness Point

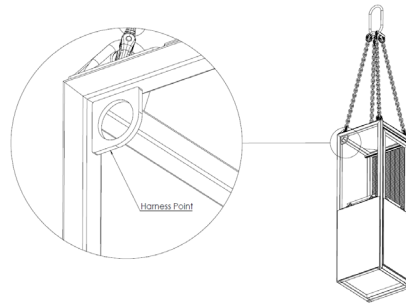

2 Person Cage Harness Point

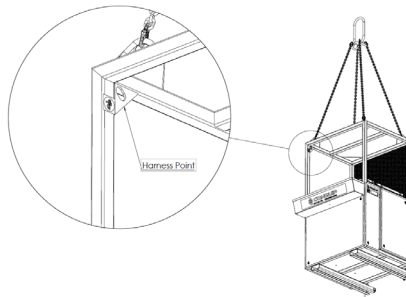

4 Person Cage Harness Point

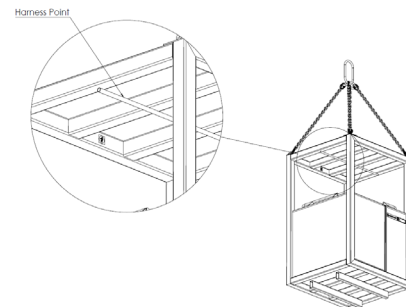

9. When you have finished with the cage, take it to its storage position and remove from the forklift or crane. If attached to a crane, lower the lifting hook and disconnect the cage's four leg lifting chain from the crane hook.
10. Do not remove the lifting chain from the cage.

6 Person Cage Harness Point

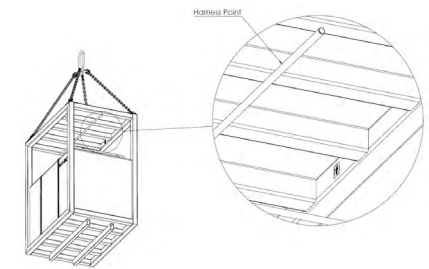

12 Person Cage Harness Point

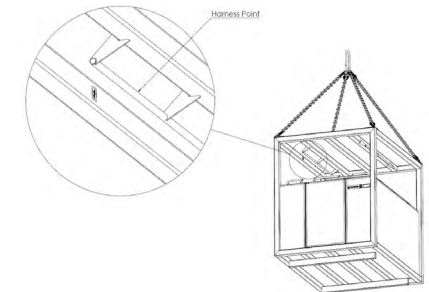

Original Working Instructions

Safety Instructions

Basic Safety

A site-specific Risk Assessment, and lift plan where applicable, must be completed by the responsible person before using this equipment to control risks, produce a safe system of work and ensure safety for you, your colleagues and others. Your risk assessment will determine the correct Personal Protective Equipment (PPE) for the task you are doing. You must use it. Conquip recommends that you should wear:

- Suitable clothing
- Gloves
- Hard hat
- Protective footwear (steel toecaps)
- Safety glasses
- Safety Harness



Important Safety Notes

- Read these instructions before using this equipment. If there is anything you do not understand or if you have any concerns do not use this equipment. Contact your supervisor or Conquip Engineering Group for advice.
- You must check that you have considered all the safety requirements for the task you are doing and that this equipment is suitable.
- You must protect bystanders and the general public by preventing access to the working area.
- Do not use this equipment if you are tired, unwell or under the influence of alcohol or drugs. If you are taking any medicine or undergoing treatment you should inform your supervisor.

Usage & Transportation

- Never unevenly load this equipment.
- The weight of the equipment, together with its attachments, must be added to the weight of the load when calculating the total load that will be imposed on the lifting apparatus / operating machine.
- This equipment must be used in conjunction with the load ratings of the lifting apparatus / operating machine. (Refer to the manufacturers' load ratings and original working instructions).
- Make sure you know how to use this equipment and understand all aspects of its operation in case of emergency.
- This equipment weighs more than 25kg. Do not lift or manhandle without machine assistance.
- Do not operate this equipment near overhead power lines.
- Take care in confined spaces, near ceilings or similar hazards. This equipment was designed for vertical lifting. Do not drag, or swing.
- Before operating this equipment, check that you have enough space for you to work safely and make sure that the working area is clear of hazards, obstructions and personnel.
- Before lowering equipment make sure that the landing zone is clear and capable of accepting the size and weight of the load.
- Crush Risk. Keep hands and feet clear of the equipment at all times to avoid injury.
- Do not exceed the maximum Working Load Limit (WLL) shown on the serial plate. Ensure that the WLL on the individual lift points is not exceeded.
- Before lifting, check that the load is secured, balanced and stable. Allow space for the equipment to move if the load shifts.
- Manoeuvre loaded or raised equipment carefully. Travel and turn slowly to avoid unit becoming unstable.

Personnel

- All personnel must wear relevant personal protective equipment.
- Do not wear loose clothing or jewellery and tie back long hair to avoid becoming tangled or trapped in this equipment. You must make everyone in the work area aware of what you are doing.
- All personnel involved in the lifting operation must be competent to do so and must have been briefed in conjunction with this User Guide available from Conquip Engineering Group, the manufacturer.

Equipment Maintenance & Cleaning

- It is mandatory that the equipment is thoroughly examined regularly, by a qualified engineer, to ensure compliance with relevant regulation/s. (Conquip recommend to carry out thorough examination every six months).
- This product may incorporate various loose and detachable items of lifting gear. Refer to the separate requirements for the safe use of those items.
- When not being used, store the unit in a clean, upright condition and in a safe place where it will be protected from thieves and unauthorised users.
- This equipment must be inspected by the responsible person before each use and then regularly, as determined by your risk assessment or working practice. If you have any concerns about condition or suitability do not use.

Disclaimer

Warranty

The products supplied by Conquip Engineering Group are all guaranteed by a 12 month warranty.

Apart from where exceptions apply, Conquip Engineering Group promises to repair or replace any fault which the Company considers to be due to defective material or workmanship within 12 months of the date of sale, at no additional cost.

- Faults arising from unauthorised alterations (see modifications section below for full details).
- Damage caused by abuse, neglect, misuse or falling.
- Damage caused because of failure to follow transportation, storage, loading, cleaning or operating instructions.
- Replacement or repair of components due to fair wear and tear.
- Any consequential damage or wear arising from the use or fitting of additional or non-standard parts.

Modifications

If any third-party modifications or alterations, involving drilling, welding, cutting or distortion of materials in any form, are to be carried out on the product, Conquip Engineering Group must provide full written approval prior to the work being carried out.

Alterations, modifications, additions or repairs must be carried out by Conquip Engineering Group's recognised distributors, if they are not carrying out the work themselves.

Conquip Engineering Group operate a continuous improvement policy and therefore reserve the right to alter technical specifications and user guide details at any point without notice.

Conquip Engineering Group will not cover or reimburse any transportation and/or shipment costs to and from their premises or their recognised agents, or any material and/or labour costs for repair, replacement or assessment against a warranty claim.

Conquip Engineering Group and/or their directors, employees, insurers or recognised agents will not be held liable for consequential damages, losses or expenses relating to the inability to use the product correctly for its purpose.

EC Declaration of Conformity

In accordance with EN ISO 17050-1:2004

Declaration: As defined by the Machinery Directive 2006/42/EC and subsequent amendments

We, CONQUIP ENGINEERING GROUP, herewith declare that the following indicated equipment meets the fundamental health and safety requirements concerning the EU guide line(s), due to their design and manufacture.

This declaration will be rendered null and void if the machine is changed without our approval.

Signed:



Dated: 2018

Garry Critchley, Managing Director

Product Code(s):

CA126-00120 / CA120AB-00240 / CA123-00480 / CA123-00720 / CA123-01440

EC Directive/Regulation:

2006/42/EC,
CA123-00480 / CA123-00720 / CA123-01440 = Lifting Operations and Lifting Equipment Regulations 1998
Provision and Use of Work Equipment Regulations 1998

Harmonised Standards:

CA126-00120 / CA120AB-00240 / CA123-00480 / CA123-00720 / CA123-01440 = BS EN ISO 12100:2010
CA123-00720 / CA123-01440 = BS EN ISO 14502

General Description/Designation:

Access Cage – CA126-00120 / CA120AB-00240 / CA123-00480 / CA123-00720 / CA123-01440

WLL:

CA126-00120 = 120kg
CA120AB-00240 = 240kg
CA123-00480 = 480kg
CA123-00720 = 720kg
CA123-01440 = 1440kg

Important Notes

- This User Guide is for this Conquip product only.
- Any movements of the product must be thoroughly planned before the work commences to identify potential hazards and assess risk.
- All personnel involved in lifting and transportation of this product must have read this User Guide and must be properly briefed.
- You must be competent, alert and medically fit when using this equipment. If you have a medical condition, a mental or physical disability, you must seek advice from a medical professional before using this equipment.

Talking to us is easy

We're here to help

Call us on 0845 520 1101

Email us at sales@cqegroup.com

www.cqegroup.com

Conquip Engineering Group

Waterbrook Estate, Alton, Hampshire, GU34 2UD

Copyright © 2018 Conquip Engineering Group. All Rights Reserved.
Access Cage User Guide - Issue 2