

USER GUIDE

MECHANICAL PRECAST GRAB

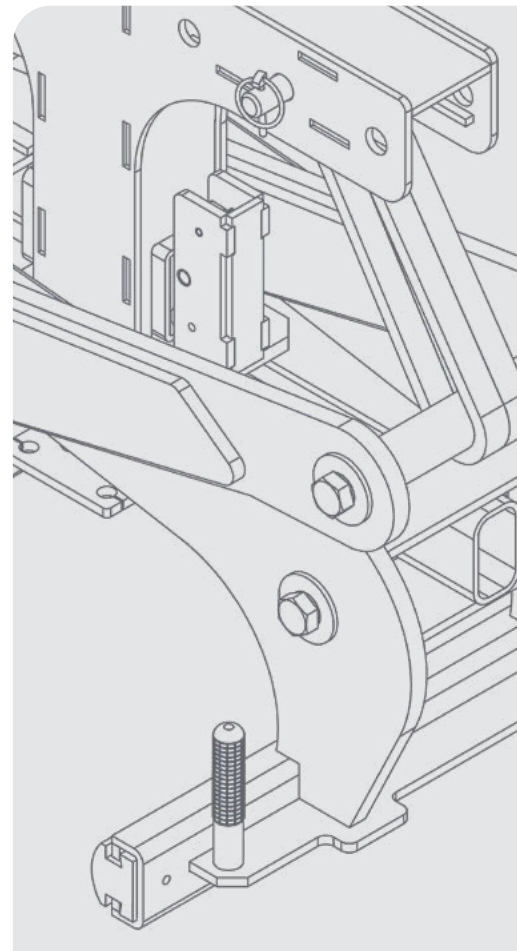
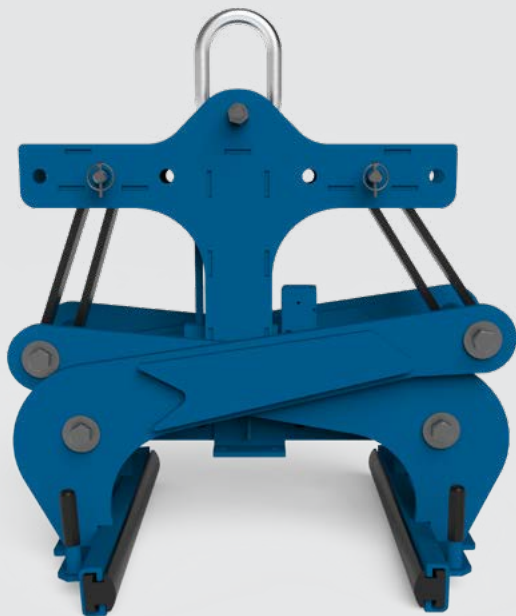

DISCLAIMER

Do not attempt to handle or operate this equipment before you have received sufficient training. Before use, operatives must have carried out all checks featured on the Visual Inspection Sheet on page 09. It is imperative that you have read the General Safety Instructions on page 10 and sufficiently familiarised yourself with the Operational Procedures in this document.

Note that this item is compliant only to the standards specified in this User Guide and it is therefore the duty of the responsible person(s) to review and ensure compliance.

CONTENTS

PRODUCT INFORMATION

INTRODUCTION	04
SPECIFICATION	05

INTENDED USE

LIFTING AND CARRYING	07
----------------------	----

OPERATIONAL PROCEDURES

IMPORTANT USAGE NOTES	08
PREPARING THE MECHANICAL PRECAST GRAB	08
CRANE LIFTING	09

MAINTENANCE & INSPECTION

MAINTENANCE REGIME	10
VISUAL INSPECTION SHEET	11

GENERAL SAFETY INSTRUCTIONS

SAFETY INSTRUCTIONS	12
GENERAL NOTES	13

LEGAL

TERMS AND CONDITIONS	14
EC DESIGN CONFORMITY	18
STANDARDS AND REGULATIONS APPLICABLE	19

INTRODUCTION

OVERVIEW

The Conquip [Mechanical Precast Grab](#) is a crane attachment, also known as a Jersey grab, that is designed to transport and place precast kerbs and concrete barriers. It is fully automatic and has a wide opening width.

KEY BENEFITS

- Automatic load and release mechanism for quick and easy material movement.
- Wide opening width allows usage with large kerbs and barriers.
- Easily adjusted by means of a locating pin.
- Handles included on the grab for accurate placement of blocks.

SPECIFICATION

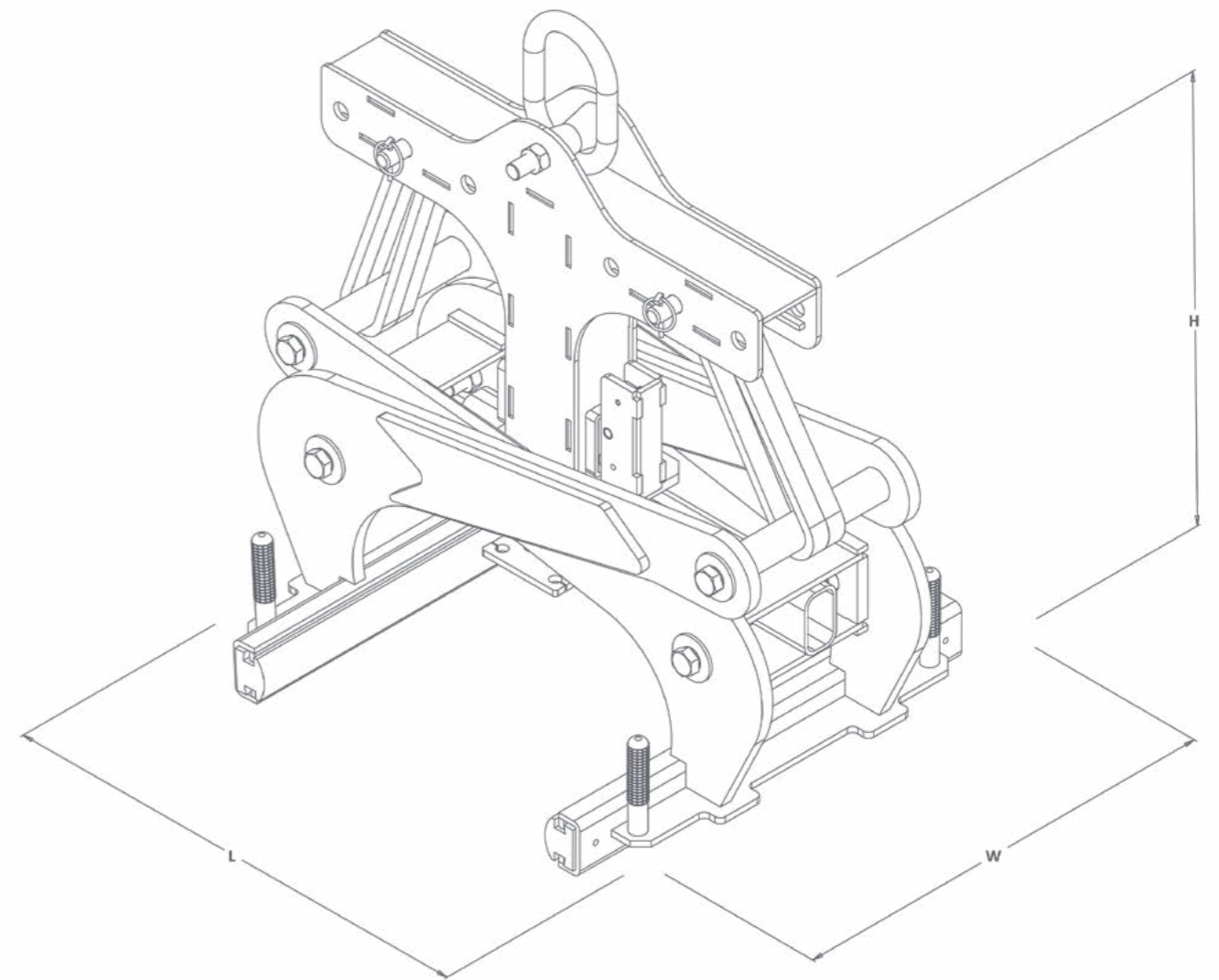

CODE	LENGTH (mm)	WIDTH (mm)	HEIGHT (mm)	WEIGHT (kg)	WLL* (kg)
CA205	950	730	910	235	4000

*Working Load Limit

INTENDED USE

LIFTING AND CARRYING

Excavators are primarily intended for the excavation and handling of loose materials and are not designed for lifting or suspending loads. The employment of excavators fitted with attachments for lifting operations, where such use is outside of standard earth-moving activities, must be properly planned, adequately supervised, and executed safely in strict compliance with Regulation 8 of the Lifting Operations and Lifting Equipment Regulations 1998 (LOLER), which requires that lifting equipment is used only for its intended purpose, inspected prior to use, and operated by competent personnel.

Furthermore, it is the responsibility of the end-user to ensure that the excavator complies with all applicable safety and design requirements, including:

- Machinery Directive 2006/42/EC, Clause 4.2.2 – requires machinery to be designed to eliminate risks during intended use and reasonably foreseeable misuse, ensuring structural integrity and operational safety when lifting attachments are employed.
- EN 474-1, Clause 4.12 – specifies requirements for stability, structural strength, and safety systems in earth-moving machinery. Compliance ensures that the excavator can safely accommodate lifting attachments without risk of overturning, structural failure, or loss of control.
- EN 474-5, Clause 4.8 – governs requirements for additional equipment and attachments, including lifting devices, ensuring mechanical compatibility, secure attachment, and safe operation within the machine's operational limits.
- Provision and Use of Work Equipment Regulations 1998 (PUWER), Regulation 4 – requires that work equipment, including attachments, is suitable for its intended task. This ensures that any lifting attachments are appropriately rated and safe for use with the excavator.
- BS 7121-1:2016 (Code of Practice for Safe Use of Cranes and Lifting Equipment), Parts on Mobile Plant Lifting – provides guidance on safe lifting practices using mobile machinery, including risk assessment, lifting planning, and operator competency, reinforcing compliance with LOLER.
- ISO 12100:2010 – Safety of Machinery: General Principles for Design – requires that machinery be designed to eliminate hazards or reduce risks to a minimum. For excavators, this ensures that any lifting operation does not compromise the original machine safety features.

End-users must verify that the excavator and any attachments are fully compliant with these provisions before undertaking any lifting operations, thereby ensuring regulatory compliance and the safety of personnel, equipment, and property.

OPERATIONAL PROCEDURES

IMPORTANT USAGE NOTES

- The Mechanical Precast Grab relies upon a 'crushing' force to grip the load prior to and during the lift. You should inspect each load prior to lifting to ensure its suitability and prevent load damage.
- Do not allow hands or feet to come between or below the lifter and the load.
- Do not attempt to adjust or manhandle a load whilst it is in a raised position.
- Do not drag the load; this equipment is for lifting the load clear of the ground.
- Ensure the Mechanical Precast Grab is kept at a sensible height and is guided by a slinger/signaller at all times to avoid personnel injury.
- Ensure the destination of the kerbs/load is stable and firm, and can take the load of the materials and the Mechanical Precast Grab.
- Do not try and attempt to lift multiple kerbs at one time.

PREPARING THE MECHANICAL PRECAST GRAB

01. Take the gripper to the material and adjust the grip faces to suit the load.
02. Adjustment is achieved by removing the linch pin and locating pin and sliding the grip faces together or apart, as required, as close to the length of the materials as possible, ensuring each grip is equidistant from the centre.
03. Replace the locating pin and linch pin.

CRANE LIFTING

01. Attach a suitable chain sling to the crane or other suitable lifting apparatus.
02. Attach the chain to the lifting point at the top of the Mechanical Precast Grab. Always ensure that the hook's gate is correctly closed.
03. Raise the grab and position over the load, checking that it is centrally aligned before lowering.
04. Lower the grab until the rest plate is resting on the load and position the grab faces either side of the material.
05. Carefully raise the load just off the ground and check for balance and security. The grab's jaws will automatically close tight on the load as it is lifted.
06. Carefully transport the load to its required destination, taking care not to jolt the load.
07. When in position, lower the load until in contact with the ground. The lifter's grips will automatically release and allow you to raise the Mechanical Precast Grab clear of the load.
08. You can now proceed to the next load, or lower the Mechanical Precast Grab to the ground and detach from the lifting chain and lifting apparatus.
09. An unloaded lifter could alter between grip and release each time it receives a jolt. This may cause the jaws to be out of sync when you next attempt to 'grab a load'. If this is the case, lower the empty Mechanical Precast Grab to the ground to alter to the release position before reloading.

MAINTENANCE & INSPECTION

MAINTENANCE REGIME

- It is mandatory that the machinery equipment is thoroughly examined regularly, by a qualified engineer, to ensure compliance with relevant regulations. Conquip recommend carrying out a thorough examination every six months.
- This machinery may incorporate various loose and detachable items including, but not limited to pins, bolt assemblies and adaption plates. Refer to the separate requirements for the safe use of those items.
- When not being used, store the unit in a clean, upright condition and in a safe place where it will be protected from thieves and unauthorised users.
- This machinery must be inspected by the responsible person before each use and then regularly, as determined by your risk assessment or working practice. If you have any concerns about the machinery's condition or suitability, do not use it.

VISUAL INSPECTION CHECKLIST

INSPECTION ITEMS	RESULTS		COMMENTS
	SATISFACTORY	UNSATISFACTORY	
Serial Number			CQ.....
Product Code			
Working Load Limit (Kg)			
Conforms to user guide specification			
Master link damaged			
Locating pins secure			
Adjustment pins secure			
Lift chains damaged			
Operation of catch mechanism			
Rubber grippers for damage and wear			
Handles damaged / bent			
General visual frame work condition			
SIGNATURE			
Name	Position	Qualification	Signature & Date

GENERAL SAFETY INSTRUCTIONS

The machinery should be properly operated and maintained to keep it in a safe, efficient operating condition. Be sure that all fixings and components are free of mud or other matter that might cause issues hazardous to the operator, serviceman, or other personnel or equipment. Report all malfunctions to those responsible for maintenance, and do not operate the equipment until corrected. Normal service or maintenance performed as required can prevent unexpected and unnecessary downtime.

This operations manual describes general inspections, servicing and operation with the normal safety precautions required for normal servicing and operating conditions. It is not a guide, however, for abnormal conditions or situations, and therefore, servicemen and operators must be safety conscious and alert to recognise potential servicing or operating safety hazards at all times, and take necessary precautions to assure safe servicing and operation of the machine.



M002
Refer to instructions manual



M004
Wear eye protection



M008
Wear safety footwear



M009
Wear protective gloves



M010
Wear protective clothing



M014
Wear head protection



M015
Wear high-visibility clothing

GENERAL NOTES

- Read this operations manual and learn the operating characteristics and limitations of the machinery. Know what operating clearances the machine requires.
- Read and understand all the safety signs prior to operation.
- If the safety signs are obstructed by dirt or debris, clean them using mild soap and water prior to operation.
- If the safety signs are damaged or illegible, replace them immediately, prior to operation.
- Be aware of operating hazards that weather changes can create on the job. Know proper procedures to follow when a severe rain or electrical storm strikes.
- Never attempt to operate or work on machinery when not feeling physically fit.
- Never wear loose clothing, rings, watches, heavy gloves etc., that might catch and result in injury.
- Know what safety equipment is required and use it. Such equipment may be: hard hat, safety glasses, reflector type vests, protective gloves and safety footwear.

TERMS & CONDITIONS

CONQUIP ENGINEERING GROUP STANDARD PRODUCT WARRANTY

01. COMMENCEMENT

1.1 This Warranty shall commence on the Commencement Date and shall continue until the earlier of:

- (a) the Expiry Date; or
- (b) the date on which it may be voided in accordance with clause 4.1(b)

when it shall terminate automatically without notice.

02. DUTY OF GOOD FAITH

2.1 The Purchaser shall in the exercise of its rights under this Warranty and in the compliance with its obligations under this Warranty be subject to and shall in all respects owe and comply with a duty of good faith to the Warrantor.

03. NATURE AND EXTENT OF COVER

3.1 Subject to clause 3.2 the Warrantor agrees and undertakes to the Purchaser that it shall be liable to the Purchaser under and in accordance with the terms of this Warranty in the event that:

- (a) prior to the Expiry Date the Purchaser shall notify a Warranty Claim to the Warrantor; and
- (b) the Equipment or any relevant part of the Equipment shall have become unusable as the result of defective material or defective workmanship prior to the Expiry Date.

3.2 The Warrantor's obligation under clause 3.1 shall be expressly subject to the provisions of clauses 4, 5 and 6 and conditional upon the Purchaser's compliance in full with the provisions of clause 7.

04. RESTRICTIONS

4.1 The following restrictions apply to this Warranty:

(a) This Warranty is personal to the Purchaser and neither the legal benefit nor legal burden of this warranty may be assigned or novated or otherwise transferred by the Purchaser to any other party. Any purported assignment, novation or transfer shall not be binding upon the Warrantor.

(b) This Warranty shall be void in the event that the Purchaser:

(i) cannot provide authentic and original documentary evidence that the Purchaser has during the period between the Commencement Date and the Expiry Date complied with the Maintenance and Servicing Requirements; and/or

(ii) has, during the period between the Commencement Date and the Expiry Date, exceeded the Purchaser's Usage Cycle Parameters; and/or

(iii) has, during the period between the Commencement Date and the Expiry Date, exceeded the Purchaser's Use Parameters; and/or

(iv) has carried out, or procured the carrying out by any third party of, any repair to the Equipment or any part of the Equipment which is not an Authorised Repair; and/or

(v) has operated the Equipment after having replaced any part of the Equipment with a part which has not been supplied and fitted by the Warrantor; and/or

(vi) has modified the Equipment in any way prior to use.

05. EXCLUSIONS

5.1 The following are excluded from the scope of this Warranty:

(a) Loss of and/ or damage to the Equipment or any part of it resulting from any collision between the Equipment and any other fixed or stationary or mobile object whatsoever, irrespective of whether that collision was or was not caused by the Purchaser; and/or

(b) Loss of and/or damage to any personal property and/or possessions or other equipment not forming part of the Equipment but which is present in or about the Equipment; and/or

(c) loss and/or damage which is covered by any other insurance policy taken out and maintained by the Purchaser or in respect of which the Purchaser has a contractual obligation to do so; and/or

(d) loss and/or damage to the equipment which is consistent with the use by the Purchaser of the Equipment:

(i) in compliance with the Maintenance and Servicing Requirements; and

(ii) in compliance with the Usage Cycle Parameters; and

(iii) in compliance with the Use Parameters; and

(iv) having only carried out Authorised Repairs to the Equipment; and

(v) having all and any replacement parts fitted by the Warrantor; and

(vi) in unmodified form.

06. LIMITATION OF LIABILITY

6.1 The Warrantor's liability to the Purchaser shall be limited as follows:

- (a) The Warrantor shall not in any circumstances be liable to the Purchaser for indirect and/or consequential and/or economic loss suffered and/or incurred as the case may be by the Purchaser; and
- (b) The Warrantor shall only be liable to the Purchaser for the reasonable and proper costs reasonably and properly incurred by the Purchaser directly in connection with the repair and/or replacement (at the Warrantor's absolute discretion) of the Equipment or any part of the Equipment; and
- (c) The Warrantor's liability to the Purchaser shall notwithstanding any other provision of this Warranty, not in any circumstances exceed the Purchase Price of the Equipment.

07. WARRANTY CLAIMS

7.1 The Purchaser shall in respect of any claim against the Warrantor under this Warranty and within 24 hours of the occurrence of the subject matter of the Warranty Claim:

- (a) Complete in full and submit to the Warrantor a Warranty Claim in the form annexed to Schedule 4;
- (b) Provide date stamped or date identifiable photographs evidencing the claim; and
- (c) Make the Equipment or the relevant part of the Equipment available to the Warrantor for inspection within 48 hours of notification of the relevant Warranty Claim.

08. ENTIRE AGREEMENT

8.1 This Warranty constitutes the entire agreement between the parties and supersedes and extinguishes all previous promises, assurances, warranties, representations and understandings between them, whether written or oral, relating to its subject matter.

8.2 Each party agrees that it shall have no remedies in respect of any statement, representation, assurance or warranty (whether made innocently or negligently) that is not set out in this Warranty. Each party agrees that it shall have no claim for innocent or negligent misrepresentation or negligent misstatement based on any statement in this Warranty.

No variation of this Warranty shall be effective unless it is in writing and signed by the parties (or their authorised representatives).

09. WAIVER

No failure or delay by a party to exercise any right or remedy provided under this Warranty or by law shall constitute a waiver of that or any other right or remedy, nor shall it prevent or restrict the further exercise of that or any other right or remedy. No single or partial exercise of such right or remedy shall prevent or restrict the further exercise of that or any other right or remedy.

10. SEVERANCE

10.1 If any provision or part-provision of this Warranty is or becomes invalid, illegal or unenforceable, it shall be deemed deleted, but that shall not affect the validity and enforceability of the rest of this Warranty.

10.2 If any provision or part-provision of this Warranty is deemed deleted under clause 10.1 the parties shall negotiate in good faith to agree a replacement provision that, to the greatest extent possible, achieves the intended commercial result of the original provision.

11. THIRD PARTY RIGHTS

11.1 This Warranty does not give rise to any rights under the Contracts (Rights of Third Parties) Act 1999 to enforce any term of this Warranty.

12. GOVERNING LAW

12.1 This Warranty and any dispute or claim (including non-contractual disputes or claims) arising out of or in connection with it or its subject matter or formation shall be governed by and construed in accordance with the law of England and Wales.

13. JURISDICTION

13.1 Each party irrevocably agrees that the courts of England and Wales shall have exclusive jurisdiction to settle any dispute or claim (including non-contractual disputes or claims) arising out of or in connection with this Warranty or its subject matter or formation.

DESIGN CONFORMITY (EC & UK)

- (01) This certificate meets the requirements of the Machinery Directive 2023/42/EC of the European Parliament and Council.
- (02) This certificate meets the requirements of the Supply of Machinery (Safety) Regulations 2008.

DETAILS

NAME & ADDRESS OF MANUFACTURER:
Conquip Engineering Group Ltd, Unit 4, Waterbrook Estate, Alton, Hampshire. GU34 2UD
NAME & ADDRESS OF PERSON TO COMPILE TECHNICAL FILE:
Name: Daniel Critchley Address: Conquip Engineering Group, Unit 4, Waterbrook Estate, Alton, Hampshire. GU34 2UD
NAME & ADDRESS OF AUTHORISED REPRESENTATIVE IF ONE HAS BEEN MANDATED BY THE MANUFACTURER:
N/A
NAME, ADDRESS, AND IDENTIFICATION NUMBER OF THE NOTIFIED BODY (01) OR APPROVED BODY (02), WHERE APPLICABLE:
N/A

EQUIPMENT DESCRIPTION

PRODUCT CODES	GENERAL DESCRIPTION / DESIGNATION	WORKING LOAD LIMIT
CA205	Mechanical Precast Grab	4000kg

HARMONISED STANDARDS & REGULATIONS

ITEM	CODE	DESCRIPTION
EC DIRECTIVE/REGULATION	2023/42/EC	Directive 2023/42/EC- new machinery directive
HARMONISED STANDARDS	BS EN ISO 12100:2010	Safety of machinery General principles for design Risk assessment and risk reduction
OTHER REGULATIONS	LOLER 1998	Lifting Operations and Lifting Equipment Regulations 1998 (LOLER)
	PUWER 1998	Provision and Use of Work Equipment Regulations 1998 (PUWER)

DECLARATION

PLACE OF DECLARATION:
Alton
DATE OF DECLARATION:
February 2026

I declare that the above equipment meets the Essential Health and Safety requirements of the
 (01) Machinery Directive 2023/42/EC of the European Parliament and Council.
 (02) Supply of Machinery (Safety) Regulations 2008 and Section 6 of the Health and Safety at Work Etc. Act 1974.

NAME:	POSITION:	SIGNATURE:
Daniel Critchley	Managing Director	

TALKING TO US IS EASY
WE'RE HERE TO HELP

Call us on 0333 300 3470
Email us at sales@cqegroup.com
www.cqegroup.com

