

USER GUIDE

EXCAVATOR PIPE LAYING HOOK

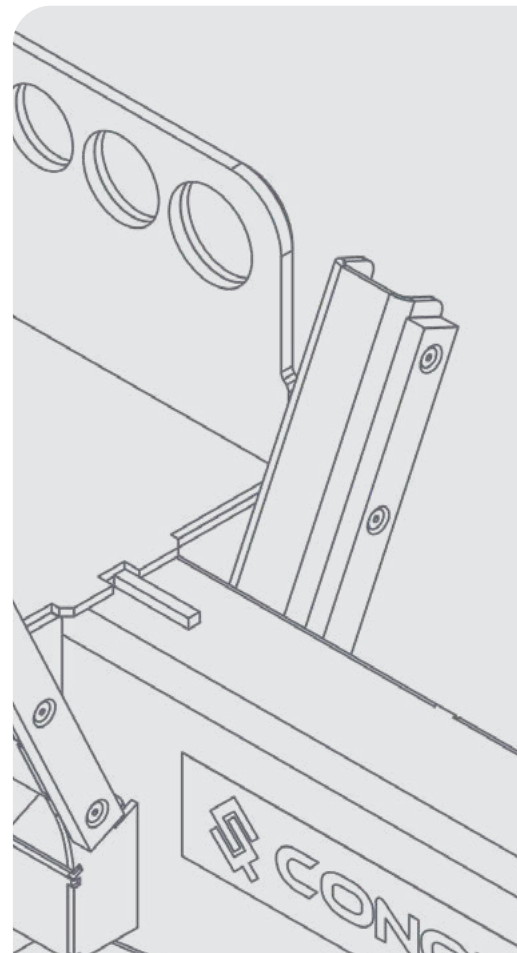
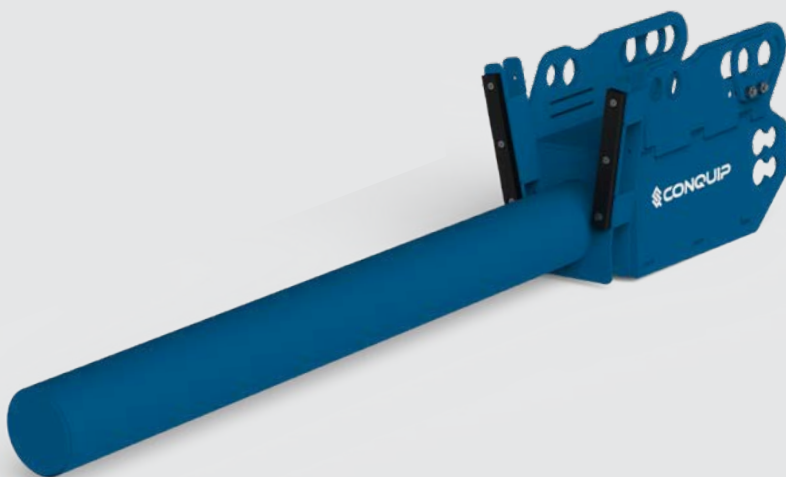

DISCLAIMER

Do not attempt to handle or operate this equipment before you have received sufficient training. Before use, operatives must have carried out all checks featured on the Visual Inspection Sheet on page 15. It is imperative that you have read the General Safety Instructions on page 16 and sufficiently familiarised yourself with the Operational Procedures in this document.

Note that this item is compliant only to the standards specified in this User Guide and it is therefore the duty of the responsible person(s) to review and ensure compliance.

CONTENTS

PRODUCT INFORMATION

INTRODUCTION	04
SPECIFICATION	05
PARTS DIAGRAM	08

INTENDED USE

LIFTING AND CARRYING	11
----------------------	----

OPERATIONAL PROCEDURES

IMPORTANT USAGE NOTES	12
SET UP	12
TO LIFT A PIPE	13

MAINTENANCE & INSPECTION

MAINTENANCE REGIME	14
VISUAL INSPECTION SHEET	15

GENERAL SAFETY INSTRUCTIONS

SAFETY INSTRUCTIONS	16
GENERAL NOTES	17

LEGAL

TERMS AND CONDITIONS	18
EC DESIGN CONFORMITY	22
STANDARDS AND REGULATIONS APPLICABLE	23

INTRODUCTION

OVERVIEW

The Conquip [Excavator Pipe Laying Hook](#) is an excavator attachment used for fast and safe handling of pipe sections. This device can be used for unloading from delivery vehicles, transporting around site and placement. It avoids the need for ground workers to be in the trench during pipe installation, and replaces traditional slinging methods for unloading trucks.

KEY BENEFITS

- Rubber stops on the back plate act as a buffer to prevent pipes from breaking when sliding into the back plate.
- The 4T Excavator Pipe Laying Hook can lift pipes with diameters from 300mm due to its cylindrical design.
- The 6T and 8.5T models can lift pipes with diameters from 375mm.
- Adjustable pin centres to fit the quick hitch of most types of excavator.
- Can be supplied with 65mm or 80mm pins to suit 13 to 22 tonne excavators or 90mm, 100mm or 110mm pins to suit 30-50 tonne excavators.
- Available in three sizes to suit varying site requirements.

SPECIFICATION

THE RANGE



PRODUCT CODE	TYPE	WEIGHT (kg)	WLL (kg)
EA012AP-04000	Excavator Pipe Laying Hook 4000	290	4000
EA012AK-06000	Excavator Pipe Laying Hook 6000	380	6000
EA012AN-08500	Excavator Pipe Laying Hook 8500	400	8500

*Working Load Limit

SPECIFICATION

ITEM	PRODUCT CODE
Excavator Pipe Laying Hook 4000	EA012AP-04000

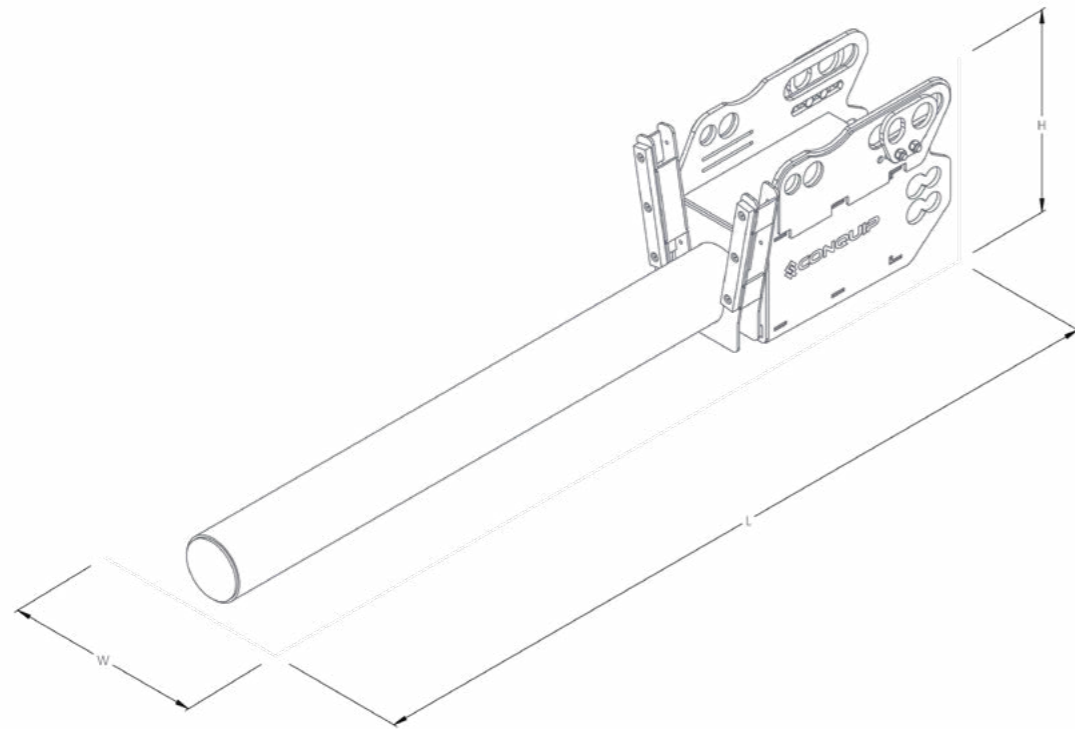

LENGTH (mm)	WIDTH (mm)	HEIGHT (mm)
2910	500	600

SPECIFICATION

ITEM	PRODUCT CODE
Excavator Pipe Laying Hook 6000	EA012AK-06000
Excavator Pipe Laying Hook 8500	EA012AN-08500

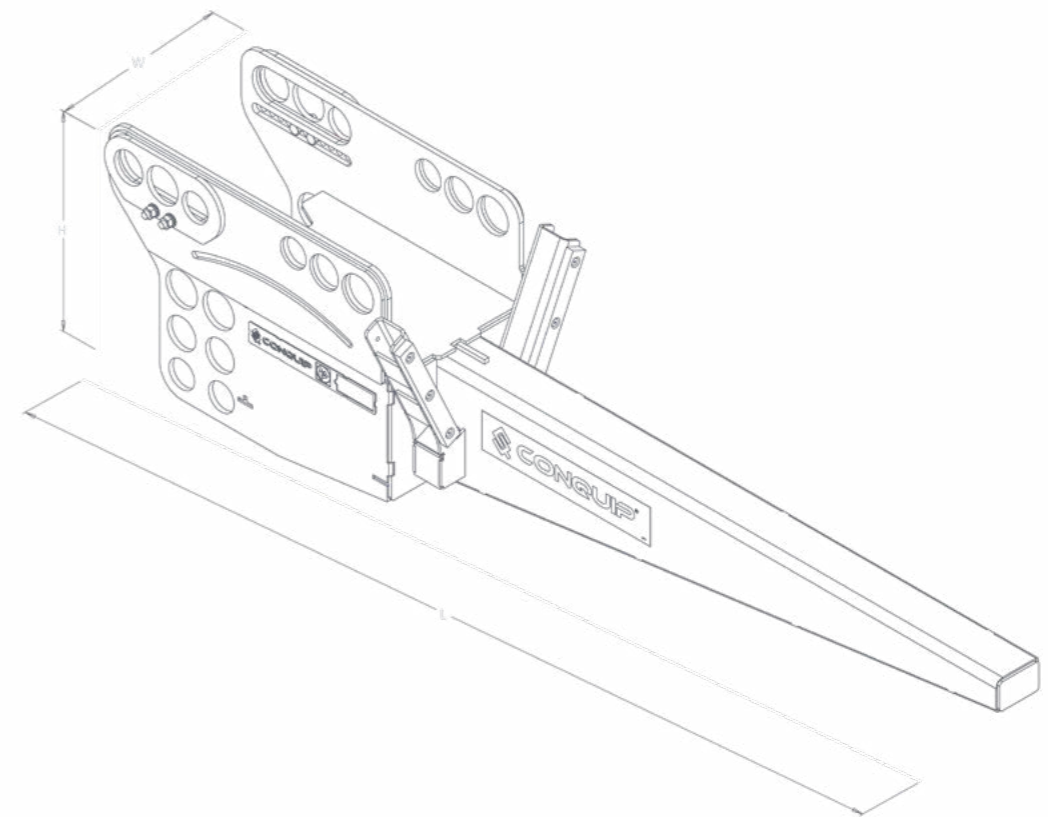

LENGTH (mm)	WIDTH (mm)	HEIGHT (mm)
2998	666	740
3010	690	750

PARTS DIAGRAM

EXCAVATOR PIPE LAYING HOOK 4000

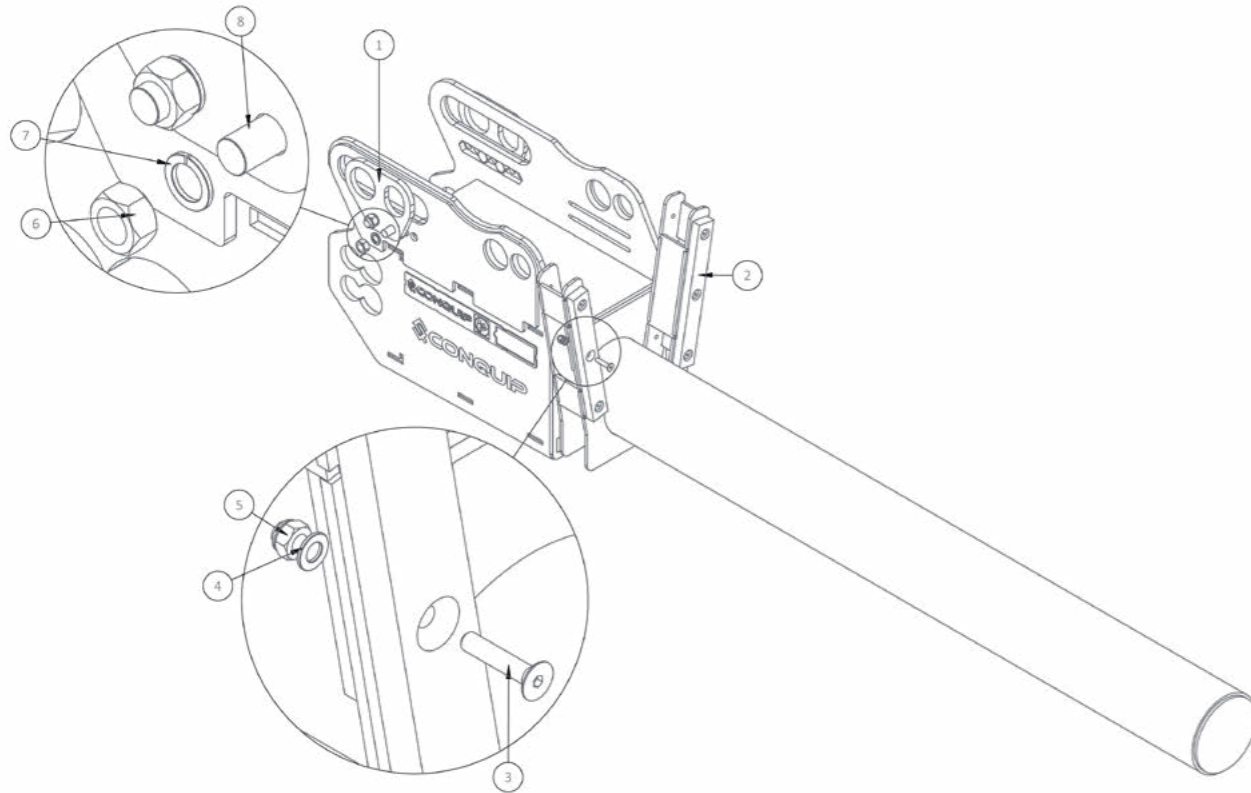

ITEM NUMBER	PART	DESCRIPTION	QUANTITY
1	ZZ130137	Adjustment Plate for Type 2 Hitch	2
2	ZZ990509	Polyurethane Buffer	2
3	Head Screw	M10x50 Socket Countersunk Head Screw	6
4	NS800018	M10 Flat Washer	6
5	NS800013	M10 Nyloc Nut	6
6	NS800280	M20 Full Nut	4
7	NS800886	M20 Spring Washer	4
8	NS800878	M20x50 Hex Head Set Screw 8.8	4

NOTE: These parts are for this model, they may differ for previous versions. Please contact Conquip with any queries.

*Working Load Limit

PARTS DIAGRAM

EXCAVATOR PIPE LAYING HOOK 6000

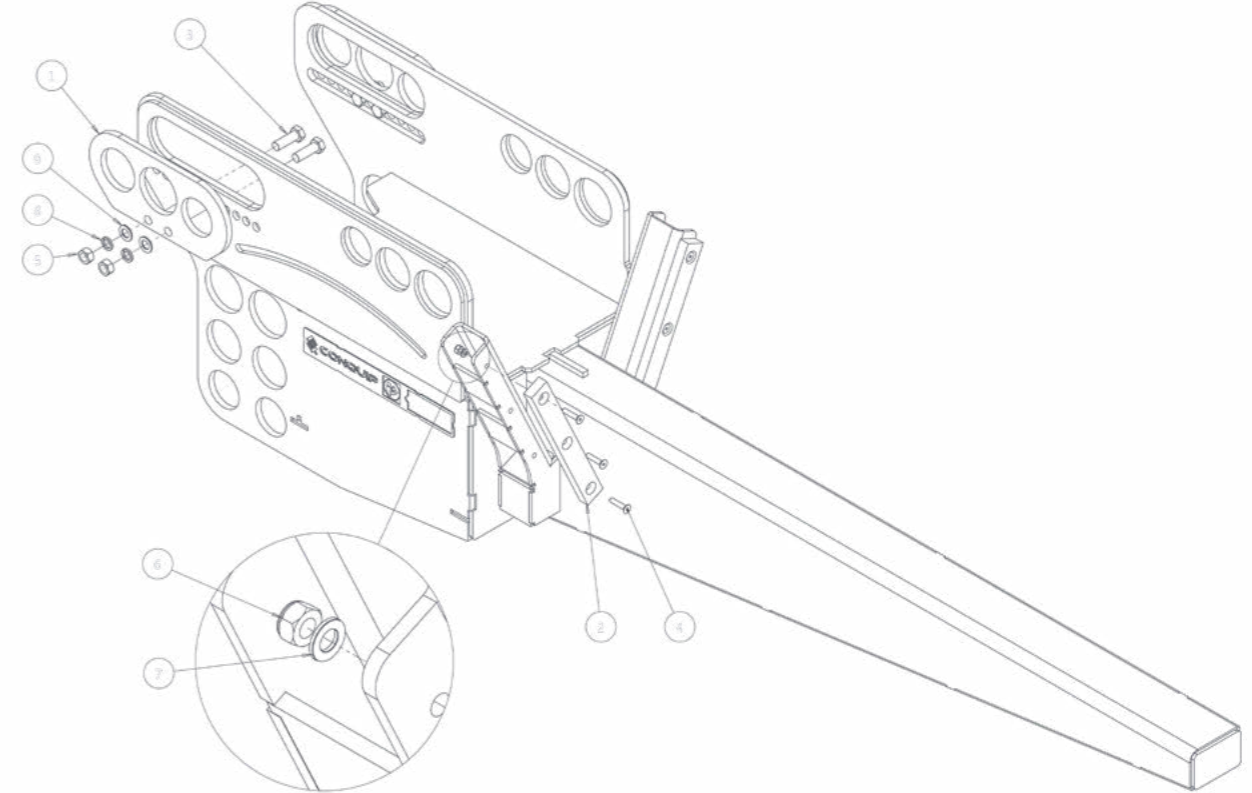

ITEM NUMBER	PART	DESCRIPTION	QUANTITY
1	EA012AF-06000-03	Adjuster Plate	2
2	ZZ990509	Rubber Buffer 400 x 50 x 24mm	2
3	M20 x 60 Hex Head Bolt	M20 x 60 Hex Head Bolt	4
4	NS800828	M10 x 50 Countersunk Bolt	6
5	M20 Full Nut	M20 Full Nut	4
6	NS800013	M10 Nyloc Nut	6
7	NS800262	M10 Washer	6
8	M20 Spring Washer	M20 Spring Washer	4
9	M20 Washer	M20 Washer	4

NOTE: These parts are for this model, they may differ for previous versions. Please contact Conquip with any queries.

PARTS DIAGRAM

EXCAVATOR PIPE LAYING HOOK 8500

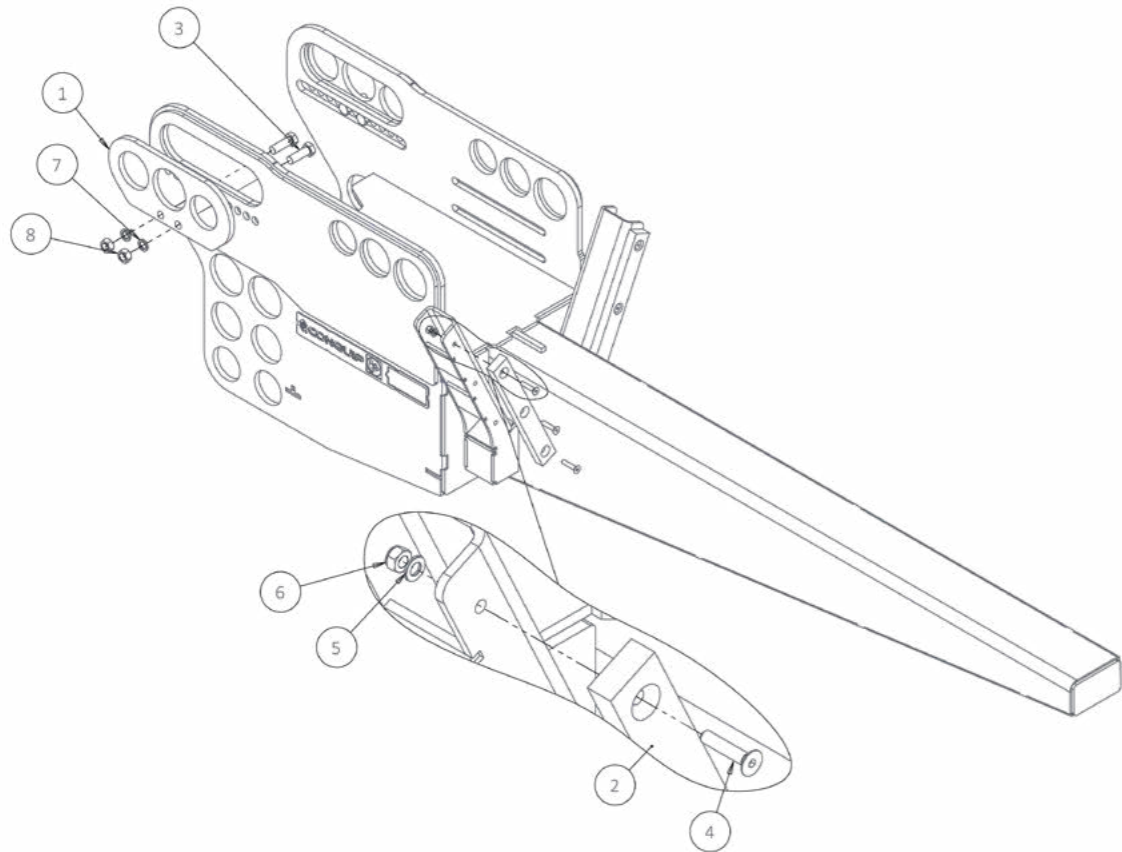

ITEM NUMBER	PART	DESCRIPTION	QUANTITY
1	EA012AN-08500-03	Adjustment Plate	2
2	ZZ990509	Polyurethane Buffer	2
3	NS800406	M20x60 Hex Head Bolt 8.8 Grade	4
4	NS800828	M10x50 Socket Countersunk Head Screw	6
5	NS800262	M10 Washer	6
6	NS800013	M10 Nyloc Nut	6
7	NS800249	M20 Spring Washer	4
8	NS800280	M20 Full Nut	4

NOTE: These parts are for this model, they may differ for previous versions. Please contact Conquip with any queries.

INTENDED USE

LIFTING AND CARRYING

Excavators are primarily intended for the excavation and handling of loose materials and are not designed for lifting or suspending loads. The employment of excavators fitted with attachments for lifting operations, where such use is outside of standard earth-moving activities, must be properly planned, adequately supervised, and executed safely in strict compliance with Regulation 8 of the Lifting Operations and Lifting Equipment Regulations 1998 (LOLER), which requires that lifting equipment is used only for its intended purpose, inspected prior to use, and operated by competent personnel.

Furthermore, it is the responsibility of the end-user to ensure that the excavator complies with all applicable safety and design requirements, including:

- Machinery Directive 2006/42/EC, Clause 4.2.2 – requires machinery to be designed to eliminate risks during intended use and reasonably foreseeable misuse, ensuring structural integrity and operational safety when lifting attachments are employed.
- EN 474-1, Clause 4.12 – specifies requirements for stability, structural strength, and safety systems in earth-moving machinery. Compliance ensures that the excavator can safely accommodate lifting attachments without risk of overturning, structural failure, or loss of control.
- EN 474-5, Clause 4.8 – governs requirements for additional equipment and attachments, including lifting devices, ensuring mechanical compatibility, secure attachment, and safe operation within the machine’s operational limits.
- Provision and Use of Work Equipment Regulations 1998 (PUWER), Regulation 4 – requires that work equipment, including attachments, is suitable for its intended task. This ensures that any lifting attachments are appropriately rated and safe for use with the excavator.
- BS 7121-1:2016 (Code of Practice for Safe Use of Cranes and Lifting Equipment), Parts on Mobile Plant Lifting – provides guidance on safe lifting practices using mobile machinery, including risk assessment, lifting planning, and operator competency, reinforcing compliance with LOLER.
- ISO 12100:2010 – Safety of Machinery: General Principles for Design – requires that machinery be designed to eliminate hazards or reduce risks to a minimum. For excavators, this ensures that any lifting operation does not compromise the original machine safety features.

End-users must verify that the excavator and any attachments are fully compliant with these provisions before undertaking any lifting operations, thereby ensuring regulatory compliance and the safety of personnel, equipment, and property.

OPERATIONAL PROCEDURES

IMPORTANT USAGE NOTES

- Ensure the work area is firm and level and clear of all obstructions with adequate room around the unit for the operator to work safely.
- Maximum load capacity of this piece of equipment is 4000kg, 6000kg or 8500kg, depending on the model. Do not exceed the maximum load.
- The lifting arm of the Excavator Pipe Laying Hook 4000 is 1.8 metres in length and can lift pipes up to a maximum length of 2.5 metres.
- Be careful not to apply too much force when pushing pipe sections together to avoid breakage of pipes.
- Check that the quick hitch is securely attached to the excavator arm following the manufacturer's instructions and giving special attention to any safety features.
- Only lift one pipe section at a time.

SET UP

01. Select the correct size pins for your machine's quick hitch.
02. Fit the front pin to the correct sized hole on the attachment.
03. Adjust the position of the rear pin to suit the quick hitch - follow the quick hitch operating guidelines and set the pins to the maximum centres for the unit.
04. Ensure the quick hitch pins have the retaining bolts correctly fitted.
05. Check for debris in the quick hitch locking mechanism and check the fit of the unit on the quick hitch, do not use if not secure.
06. When moving pipes, operators should be aware that the pipes may roll and should have a method prepared for securing the pipes.

TO LIFT A PIPE

01. When it is safe to proceed, raise the pipe lifter until the tip is just below the crown of the pipe section, then fully insert the boom into the bore as straight as possible and slightly tilted back.
02. Lift the bar carefully and keep it level so that it fully contacts the crown.
03. Lift the pipe clear of the delivery vehicle or ground.
04. When travelling with a load, tilt the pipe lifter back by 10 to 20 degrees to secure the pipe on the hook. Keep it in the lowest practicable position, to maintain driver visibility.
05. Operators should allow for any rough or sloping ground when assessing the method of operating.
06. Carefully lower the pipe onto the ground or storage location. Take care of edges or other items on hard ground. Use suitable measures to prevent the pipe from rolling.
07. When laying the pipe sections, manoeuvre into position and use the rubber buffers to push the pipe sections together.

MAINTENANCE & INSPECTION

MAINTENANCE REGIME

- It is mandatory that the equipment is thoroughly examined regularly, by a qualified engineer, to ensure compliance with relevant regulations. Conquip recommend carrying out a thorough examination every six months.
- This equipment may incorporate various loose and detachable items including, but not limited to pins, bolt assemblies and adaption plates. Refer to the separate requirements for the safe use of those items.
- When not being used, store the unit in a clean, upright condition and in a safe place where it will be protected from thieves and unauthorised users.
- This equipment must be inspected by the responsible person before each use and then regularly, as determined by your risk assessment or working practice. If you have any concerns about the equipment's condition or suitability, do not use it.

VISUAL INSPECTION CHECKLIST

INSPECTION ITEMS	RESULTS		COMMENTS
	SATISFACTORY	UNSATISFACTORY	
Serial Number			CQ.....
Product Code			
Working Load Limit (kg)			
Conforms to user guide specification			
Check adjuster plate bolts are tight			
Check excavator pins are secure			
Check rubber stops for wear or damage			
General visual body inspection			
SIGNATURE			
Name	Position	Qualification	Signature & Date

GENERAL SAFETY INSTRUCTIONS

The equipment should be properly operated and maintained to keep it in a safe, efficient operating condition. Be sure that all fixings and components are free of mud or other matter that might cause issues hazardous to the operator, serviceman, or other personnel or equipment. Report all malfunctions to those responsible for maintenance, and do not operate the equipment until corrected. Normal service or maintenance performed as required can prevent unexpected and unnecessary downtime.

This operations manual describes general inspections, servicing and operation with the normal safety precautions required for normal servicing and operating conditions. It is not a guide, however, for abnormal conditions or situations, and therefore, servicemen and operators must be safety conscious and alert to recognise potential servicing or operating safety hazards at all times, and take necessary precautions to assure safe servicing and operation of the equipment.



M002
Refer to instructions manual



M004
Wear eye protection



M008
Wear safety footwear



M009
Wear protective gloves



M010
Wear protective clothing



M014
Wear head protection



M015
Wear high-visibility clothing

GENERAL NOTES

- Read this operations manual and learn the operating characteristics and limitations of the equipment. Know what operating clearances the machine requires.
- Read and understand all the safety signs prior to operation.
- If the safety signs are obstructed by dirt or debris, clean them using mild soap and water prior to operation.
- If the safety signs are damaged or illegible, replace them immediately, prior to operation.
- Be aware of operating hazards that weather changes can create on the job. Know proper procedures to follow when a severe rain or electrical storm strikes.
- Never attempt to operate or work on machinery when not feeling physically fit.
- Never wear loose clothing, rings, watches, heavy gloves etc., that might catch and result in injury.
- Know what safety equipment is required and use it. Such equipment may be: hard hat, safety glasses, reflector type vests, protective gloves and safety footwear.

TERMS & CONDITIONS

CONQUIP ENGINEERING GROUP STANDARD PRODUCT WARRANTY

01. COMMENCEMENT

1.1 This Warranty shall commence on the Commencement Date and shall continue until the earlier of:

- (a) the Expiry Date; or
- (b) the date on which it may be voided in accordance with clause 4.1(b)

when it shall terminate automatically without notice.

02. DUTY OF GOOD FAITH

2.1 The Purchaser shall in the exercise of its rights under this Warranty and in the compliance with its obligations under this Warranty be subject to and shall in all respects owe and comply with a duty of good faith to the Warrantor.

03. NATURE AND EXTENT OF COVER

3.1 Subject to clause 3.2 the Warrantor agrees and undertakes to the Purchaser that it shall be liable to the Purchaser under and in accordance with the terms of this Warranty in the event that:

- (a) prior to the Expiry Date the Purchaser shall notify a Warranty Claim to the Warrantor; and
- (b) the Equipment or any relevant part of the Equipment shall have become unusable as the result of defective material or defective workmanship prior to the Expiry Date.

3.2 The Warrantor's obligation under clause 3.1 shall be expressly subject to the provisions of clauses 4, 5 and 6 and conditional upon the Purchaser's compliance in full with the provisions of clause 7.

04. RESTRICTIONS

4.1 The following restrictions apply to this Warranty:

(a) This Warranty is personal to the Purchaser and neither the legal benefit nor legal burden of this warranty may be assigned or novated or otherwise transferred by the Purchaser to any other party. Any purported assignment, novation or transfer shall not be binding upon the Warrantor.

(b) This Warranty shall be void in the event that the Purchaser:

(i) cannot provide authentic and original documentary evidence that the Purchaser has during the period between the Commencement Date and the Expiry Date complied with the Maintenance and Servicing Requirements; and/or

(ii) has, during the period between the Commencement Date and the Expiry Date, exceeded the Purchaser's Usage Cycle Parameters; and/or

(iii) has, during the period between the Commencement Date and the Expiry Date, exceeded the Purchaser's Use Parameters; and/or

(iv) has carried out, or procured the carrying out by any third party of, any repair to the Equipment or any part of the Equipment which is not an Authorised Repair; and/or

(v) has operated the Equipment after having replaced any part of the Equipment with a part which has not been supplied and fitted by the Warrantor; and/or

(vi) has modified the Equipment in any way prior to use.

05. EXCLUSIONS

5.1 The following are excluded from the scope of this Warranty:

(a) Loss of and/ or damage to the Equipment or any part of it resulting from any collision between the Equipment and any other fixed or stationary or mobile object whatsoever, irrespective of whether that collision was or was not caused by the Purchaser; and/or

(b) Loss of and/or damage to any personal property and/or possessions or other equipment not forming part of the Equipment but which is present in or about the Equipment; and/or

(c) loss and/or damage which is covered by any other insurance policy taken out and maintained by the Purchaser or in respect of which the Purchaser has a contractual obligation to do so; and/or

(d) loss and/or damage to the equipment which is consistent with the use by the Purchaser of the Equipment:

(i) in compliance with the Maintenance and Servicing Requirements; and

(ii) in compliance with the Usage Cycle Parameters; and

(iii) in compliance with the Use Parameters; and

(iv) having only carried out Authorised Repairs to the Equipment; and

(v) having all and any replacement parts fitted by the Warrantor; and

(vi) in unmodified form.

06. LIMITATION OF LIABILITY

6.1 The Warrantor's liability to the Purchaser shall be limited as follows:

- (a) The Warrantor shall not in any circumstances be liable to the Purchaser for indirect and/or consequential and/or economic loss suffered and/or incurred as the case may be by the Purchaser; and
- (b) The Warrantor shall only be liable to the Purchaser for the reasonable and proper costs reasonably and properly incurred by the Purchaser directly in connection with the repair and/or replacement (at the Warrantor's absolute discretion) of the Equipment or any part of the Equipment; and
- (c) The Warrantor's liability to the Purchaser shall notwithstanding any other provision of this Warranty, not in any circumstances exceed the Purchase Price of the Equipment.

07. WARRANTY CLAIMS

7.1 The Purchaser shall in respect of any claim against the Warrantor under this Warranty and within 24 hours of the occurrence of the subject matter of the Warranty Claim:

- (a) Complete in full and submit to the Warrantor a Warranty Claim in the form annexed to Schedule 4;
- (b) Provide date stamped or date identifiable photographs evidencing the claim; and
- (c) Make the Equipment or the relevant part of the Equipment available to the Warrantor for inspection within 48 hours of notification of the relevant Warranty Claim.

08. ENTIRE AGREEMENT

8.1 This Warranty constitutes the entire agreement between the parties and supersedes and extinguishes all previous promises, assurances, warranties, representations and understandings between them, whether written or oral, relating to its subject matter.

8.2 Each party agrees that it shall have no remedies in respect of any statement, representation, assurance or warranty (whether made innocently or negligently) that is not set out in this Warranty. Each party agrees that it shall have no claim for innocent or negligent misrepresentation or negligent misstatement based on any statement in this Warranty.

No variation of this Warranty shall be effective unless it is in writing and signed by the parties (or their authorised representatives).

09. WAIVER

No failure or delay by a party to exercise any right or remedy provided under this Warranty or by law shall constitute a waiver of that or any other right or remedy, nor shall it prevent or restrict the further exercise of that or any other right or remedy. No single or partial exercise of such right or remedy shall prevent or restrict the further exercise of that or any other right or remedy.

10. SEVERANCE

10.1 If any provision or part-provision of this Warranty is or becomes invalid, illegal or unenforceable, it shall be deemed deleted, but that shall not affect the validity and enforceability of the rest of this Warranty.

10.2 If any provision or part-provision of this Warranty is deemed deleted under clause 10.1 the parties shall negotiate in good faith to agree a replacement provision that, to the greatest extent possible, achieves the intended commercial result of the original provision.

11. THIRD PARTY RIGHTS

11.1 This Warranty does not give rise to any rights under the Contracts (Rights of Third Parties) Act 1999 to enforce any term of this Warranty.

12. GOVERNING LAW

12.1 This Warranty and any dispute or claim (including non-contractual disputes or claims) arising out of or in connection with it or its subject matter or formation shall be governed by and construed in accordance with the law of England and Wales.

13. JURISDICTION

13.1 Each party irrevocably agrees that the courts of England and Wales shall have exclusive jurisdiction to settle any dispute or claim (including non-contractual disputes or claims) arising out of or in connection with this Warranty or its subject matter or formation.

DESIGN CONFORMITY (EC & UK)

- (01) This certificate meets the requirements of the Machinery Directive 2023/42/EC of the European Parliament and Council.
- (02) This certificate meets the requirements of the Supply of Machinery (Safety) Regulations 2008.

DETAILS

NAME & ADDRESS OF MANUFACTURER:
Conquip Engineering Group Ltd, Unit 4, Waterbrook Estate, Alton, Hampshire. GU34 2UD
NAME & ADDRESS OF PERSON TO COMPILE TECHNICAL FILE:
Name: Daniel Critchley Address: Conquip Engineering Group, Unit 4, Waterbrook Estate, Alton, Hampshire. GU34 2UD
NAME & ADDRESS OF AUTHORISED REPRESENTATIVE IF ONE HAS BEEN MANDATED BY THE MANUFACTURER:
N/A
NAME, ADDRESS, AND IDENTIFICATION NUMBER OF THE NOTIFIED BODY (01) OR APPROVED BODY (02), WHERE APPLICABLE:
N/A

EQUIPMENT DESCRIPTION

PRODUCT CODE(S)	GENERAL DESCRIPTION	WORKING LOAD LIMIT
EA012AP-04000	Excavator Pipe Laying Hook 4000	4000kg
EA012AK-06000	Excavator Pipe Laying Hook 6000	6000kg
EA012AN-08500	Excavator Pipe Laying Hook 8500	8500kg

HARMONISED STANDARDS & REGULATIONS

ITEM	CODE	DESCRIPTION
EC DIRECTIVE/REGULATION	2023/42/EC	Directive 2023/42/EC- new machinery directive
HARMONISED STANDARDS	BS EN ISO 12100:2010	Safety of machinery General principles for design Risk assessment and risk reduction
OTHER REGULATIONS	LOLER 1998	Lifting Operations and Lifting Equipment Regulations 1998 (LOLER)
	PUWER 1998	Provision and Use of Work Equipment Regulations 1998 (PUWER)

DECLARATION

PLACE OF DECLARATION:
Alton
DATE OF DECLARATION:
February 2026

I declare that the above equipment meets the Essential Health and Safety requirements of the

- (01) Machinery Directive 2023/42/EC of the European Parliament and Council.
- (02) Supply of Machinery (Safety) Regulations 2008 and Section 6 of the Health and Safety at Work Etc. Act 1974.

NAME:	POSITION:	SIGNATURE:
Daniel Critchley	Managing Director	

TALKING TO US IS EASY
WE'RE HERE TO HELP

Call us on 0333 300 3470
Email us at sales@cqegroup.com
www.cqegroup.com

