

USER GUIDE

FORMWORK RACK

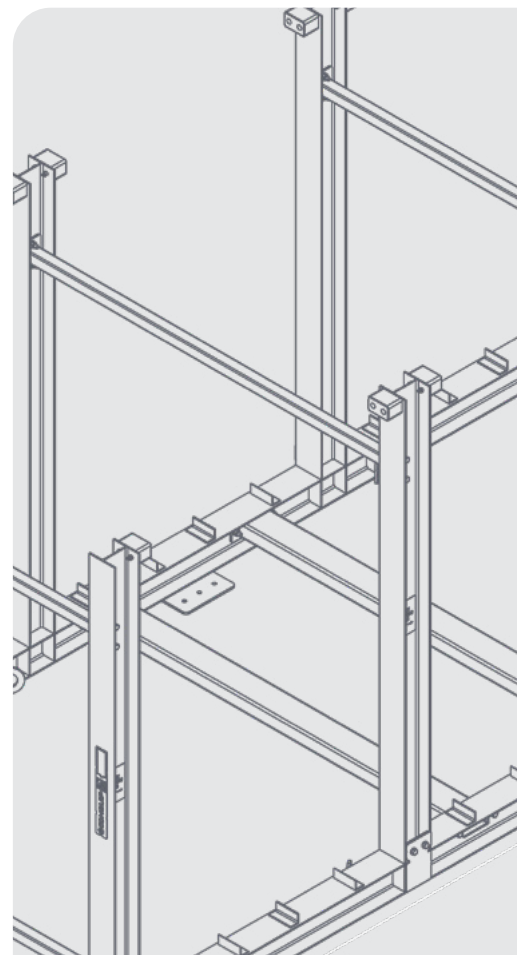

DISCLAIMER

Do not attempt to handle or operate this equipment before you have received sufficient training. Before use, operatives must have carried out all checks featured on the Visual Inspection Sheet on page 19. It is imperative that you have read the General Safety Instructions on page 20 and sufficiently familiarised yourself with the Operational Procedures in this document.

Note that this item is compliant only to the standards specified in this User Guide and it is therefore the duty of the responsible person(s) to review and ensure compliance.

CONTENTS

PRODUCT INFORMATION

INTRODUCTION	04
SPECIFICATION	05
PARTS DIAGRAM	06

OPERATIONAL PROCEDURES

IMPORTANT USAGE NOTES	08
LIFTING WITH A FORKLIFT	09
LIFTING WITH A CRANE	10
USAGE INSTRUCTIONS	10
LOADING THE RACK	10
UNLOADING THE RACK	12
PANEL COMPATIBILITY	13

MAINTENANCE & INSPECTION

MAINTENANCE REGIME	18
VISUAL INSPECTION SHEET	19

GENERAL SAFETY INSTRUCTIONS

SAFETY INSTRUCTIONS	20
GENERAL NOTES	21

LEGAL

TERMS AND CONDITIONS	22
EC DESIGN CONFORMITY	26
STANDARDS AND REGULATIONS APPLICABLE	27

INTRODUCTION

OVERVIEW

The Conquip [Formwork Rack](#) is a framework stillage designed for storing formwork panels. Available in two variations, 15kN and 8kN, it is suitable for a range of different formwork panel shapes and sizes.

Multiple panels can be stored within each bay of the rack and the rubber stops at the top of each upright hold panels in place when the rack is loaded, preventing damage to them.

Its 'toast rack' design provides easy access to the panels and fork pockets ensure the Formwork Rack can be manoeuvred around site by a forklift or telehandler when it is empty.

KEY BENEFITS

- Large capacity for storing multiple formwork panels of different shapes and sizes.
- Safe storage method that provides easy access to formwork panels.
- Fitted with rubber stops at the top of the rack to ensure panels do not slide and are held firmly in place.
- Available in two sizes to accommodate varying sizes of formwork.
- Manufactured from high-quality steel for a longer product lifecycle.
- Fork pockets allow for easy manoeuvre around site when empty.

SPECIFICATION

ITEM	PRODUCT CODE
Formwork Rack - 15kN	ST127AA-05400
Formwork Rack - 8kN	ST127AB-05400

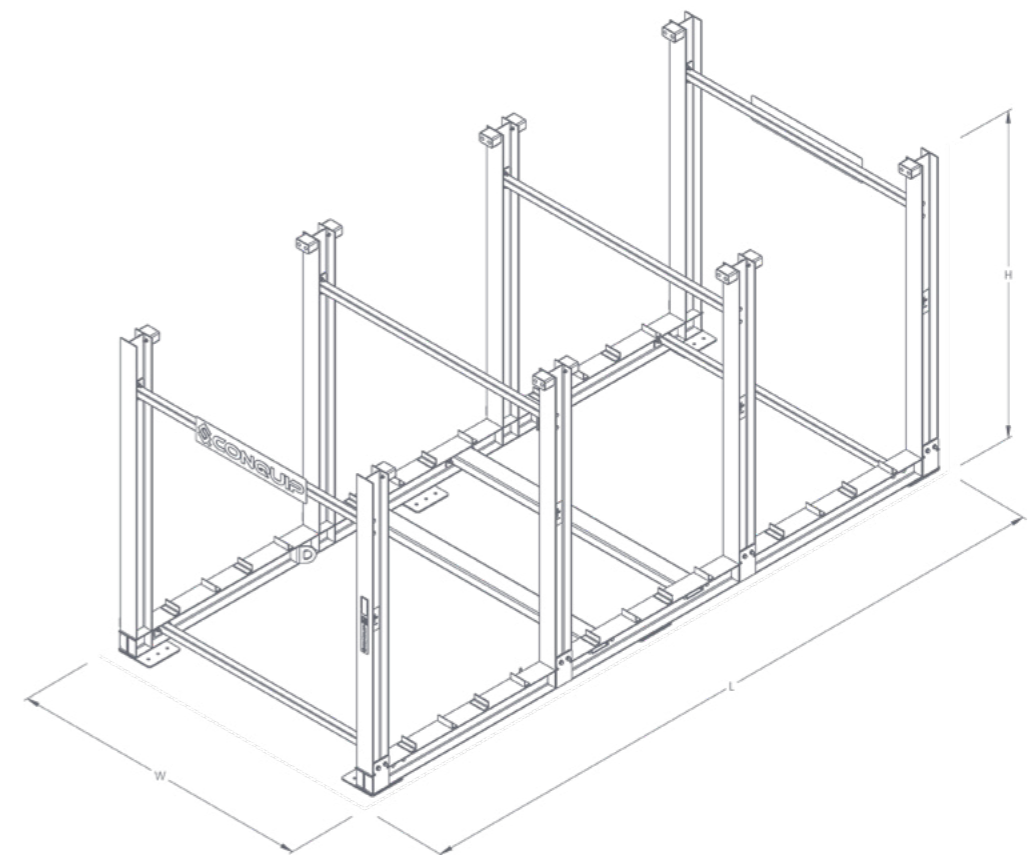

CODE	LENGTH (mm)	WIDTH (mm)	BAY WIDTH (mm)	HEIGHT (mm)	WEIGHT (kg)	LIFTING POINTS
ST127AA-05400	5400	2420	1570	2570	1590	4
ST127AB-05400	5400	2420	1570	2570	1000	4

PARTS DIAGRAM

FORMWORK RACK - 15KN

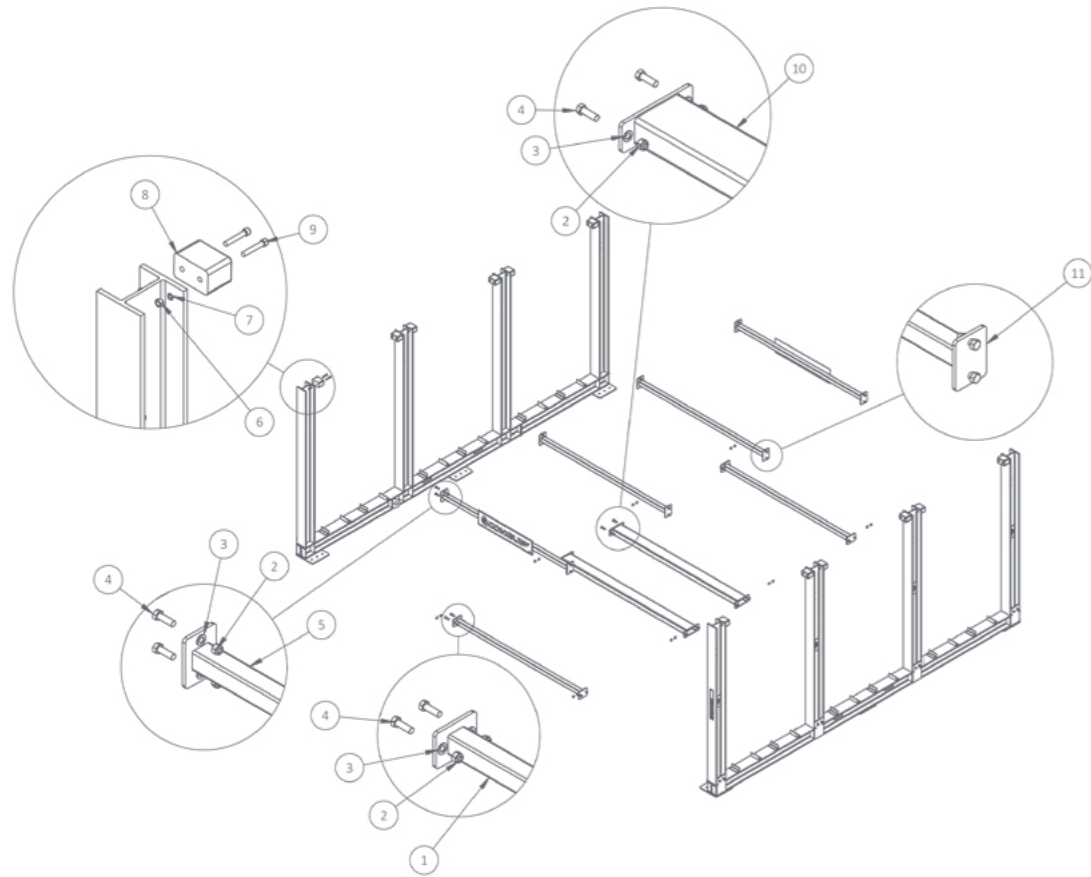

ITEM NUMBER	PART	DESCRIPTION	QUANTITY
1	ST127AA-05400-06	Lower Cross Beam Assembly	2
2	NS800121	M16 Nyloc Nut	32
3	NS800347	M16 Flat Washer	32
4	NS800646	M16x50 Hex Head Bolt 8.8	32
5	ST127AA-05400-08	Cross Beam Assembly	2
6	NS800542	M12 Full Nut	24
7	NS800887	M12 Spring Washer	24
8	ZZ990407	Rubber Buffer 120 x 75 x 80	12
9	NS800983	M12 x 70 Socket Cap Screw	24
10	ST127AA-05400-07	Fork Pocket Assembly	2
11	ST127AA-05400-04	Cross Beam Assembly	2

NOTE: These parts are for this model, they may differ for previous versions. Please contact Conquip with any queries.

PARTS DIAGRAM

FORMWORK RACK - 8KN

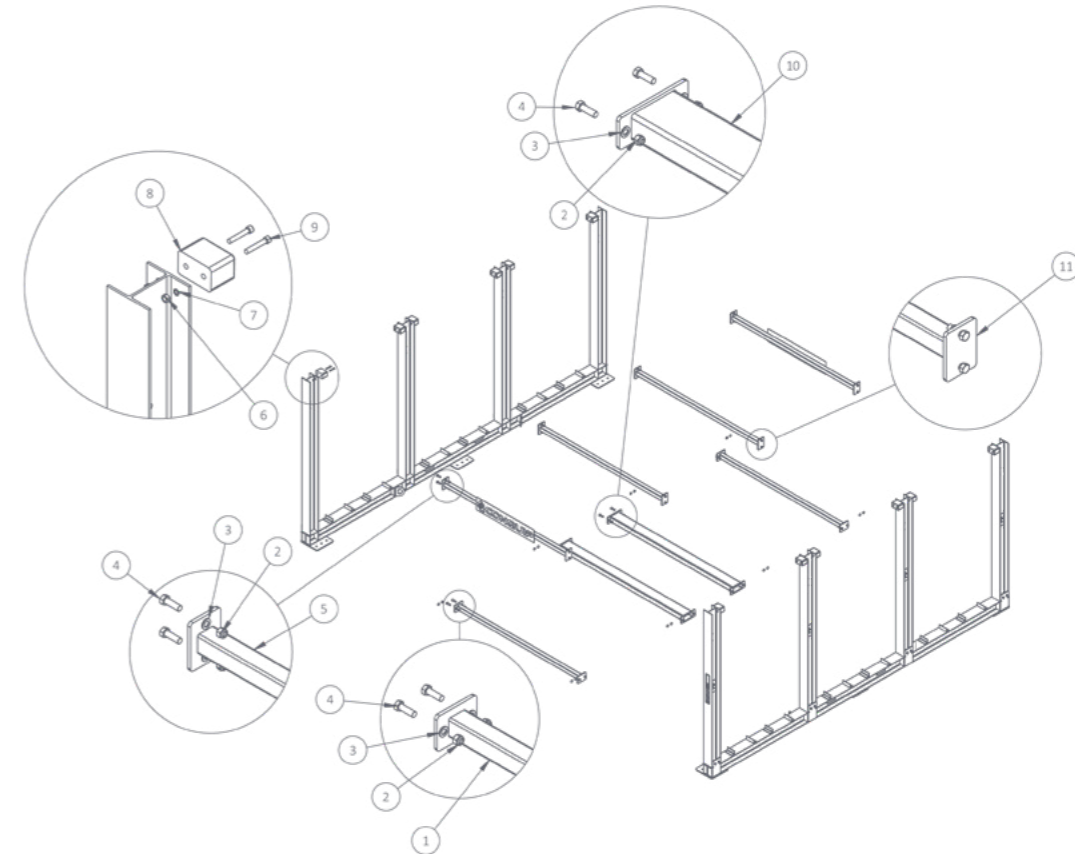

ITEM NUMBER	PART	DESCRIPTION	QUANTITY
1	ST127AB-05400-06	Lower Cross Beam Assembly	2
2	NS800121	M16 Nyloc Nut	32
3	NS800347	M16 Flat Washer	32
4	NS800646	M16x50 Hex Head Bolt 8.8	32
5	ST127AB-05400-08	Cross Beam Assembly	2
6	NS800542	M12 Full Nut	24
7	NS800887	M12 Spring Washer	24
8	ZZ990407	Rubber Buffer 120 x 75 x 80	12
9	NS800983	M12 x 70 Socket Cap Screw	24
10	ST127AB-05400-07	Fork Pocket Assembly	2
11	ST127AB-05400-04	Cross Beam Assembly	2

OPERATIONAL PROCEDURES

IMPORTANT USAGE NOTES

- Ensure the ground is flat and free from obstacles, services or machinery. Make sure the lifting equipment, forklift or telehandler is suitably rated to carry the Formwork Rack when unladen.
- The Formwork Rack must only be lifted when empty and unladen, do not lift when materials are still stored within the rack.
- The horizontal loading on the Formwork Rack uprights will vary depending on the weight, size and angle of the formwork panels stored in the Formwork Rack.
- Conquip advises all formwork panels should be placed at a minimum of 80° to the horizontal and each rack section loaded evenly to minimise this loading.
- It is the responsibility of the customer to ensure the horizontal load applied to the individual uprights does not exceed the 7.5kN (15kN per upright pair) or 4kN (8kN per upright pair) depending on the model used.
- Conquip recommends storing a maximum of three panels against an upright per section.
- The Formwork Rack should be loaded from the centre section and outwards symmetrically to prevent overturning. Conquip recommend bolting/anchoring to the ground to aid stability.
- Personnel must be cautious around the rack as large panels could be stored that exceed the size of the Formwork Rack itself.
- Do not allow personnel near the Formwork Rack if you are using heavy machinery to load or unload panels from it.



LIFTING WITH A FORKLIFT

01. To lift the Formwork Rack with a forklift, set the machine's forks to the correct width for the Formwork Rack's fork pockets. Make sure that they are equidistant from the centre.
02. Drive the forklift to the Formwork Rack, aligning the forks with the fork pockets.
03. Move the forklift forward until the forks are fully inserted into the fork pockets. The Formwork Rack is now ready to lift.
04. Carefully raise the rack just off the ground and check for balance and security.



05. Carefully transport the rack to its required destination, taking care not to jolt.



06. When in position, the rack can be lowered onto firm, level ground, free from obstructions.
07. Reverse the forklift back and clear of the rack.

LIFTING WITH A CRANE

01. Attach a suitable four-leg chain sling to the four Formwork Rack's lifting points.

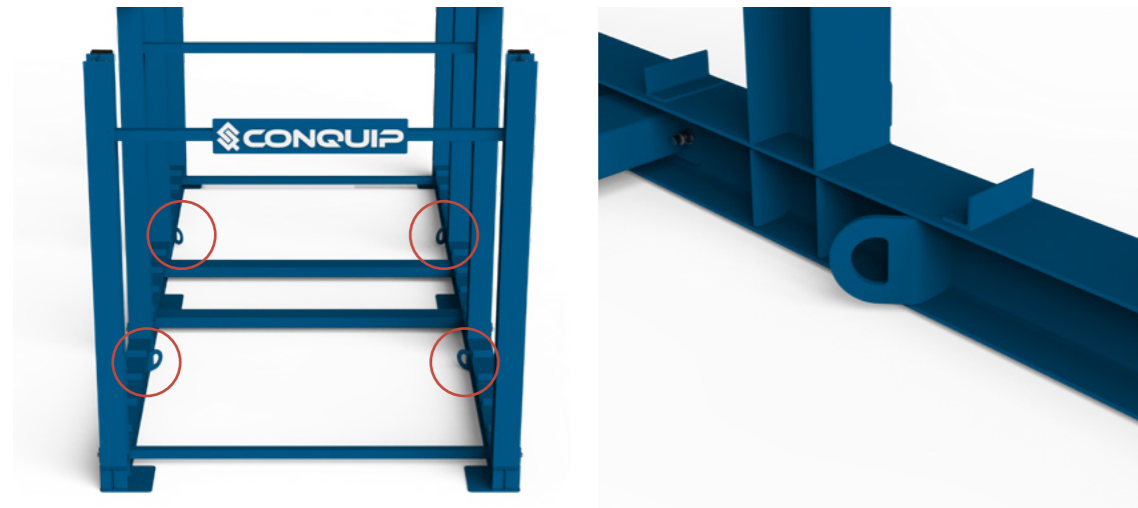

- 02. Carefully raise the rack just off the ground and check for balance and security.
- 03. Attach a tag line to aid positioning of the Formwork Rack.
- 04. Carefully transport the rack to its required destination, taking care not to jolt.
- 05. When in position, the rack can be lowered onto firm, level ground, free from obstructions, using the tag line to assist.
- 06. Detach the four-leg lifting chain from the Formwork Rack's lifting points.

USAGE INSTRUCTIONS

LOADING THE RACK

01. Before loading the Formwork Rack decide whether the Formwork Rack will be used free-standing or secured to the ground. Conquip recommend bolting/anchoring it to the ground to aid stability.

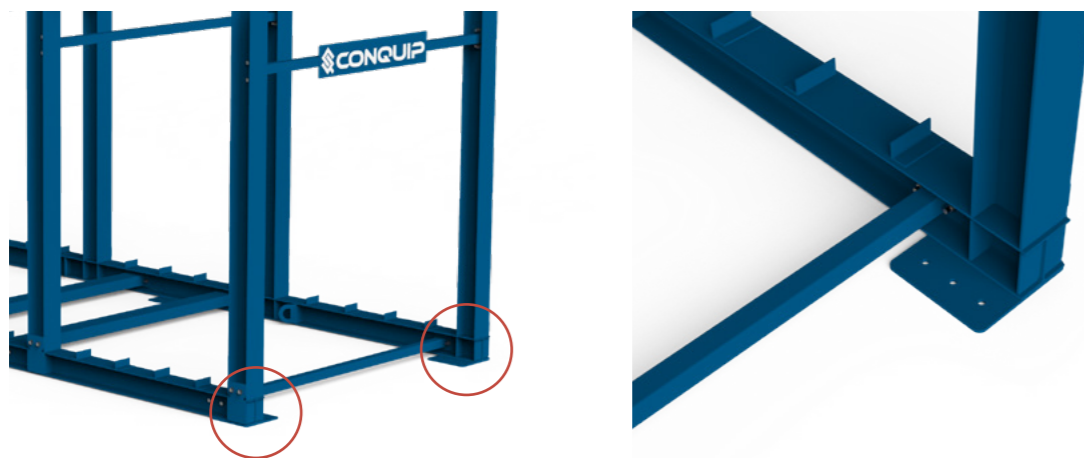

02. When loading formwork panels into an empty Formwork Rack, ensure that the first panel is positioned in the central section.

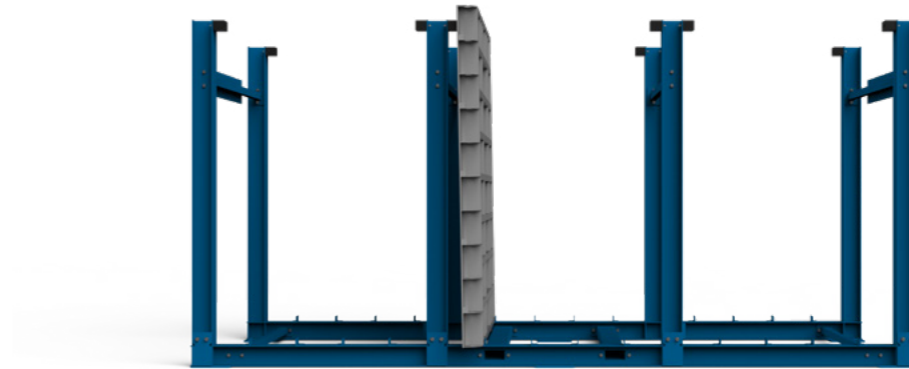

03. Then load the remaining formwork panels into the rack, working outwards from the centre and ensuring the panels are evenly and symmetrically loaded. This is particularly essential when using the Formwork Rack free-standing to prevent creating instability.

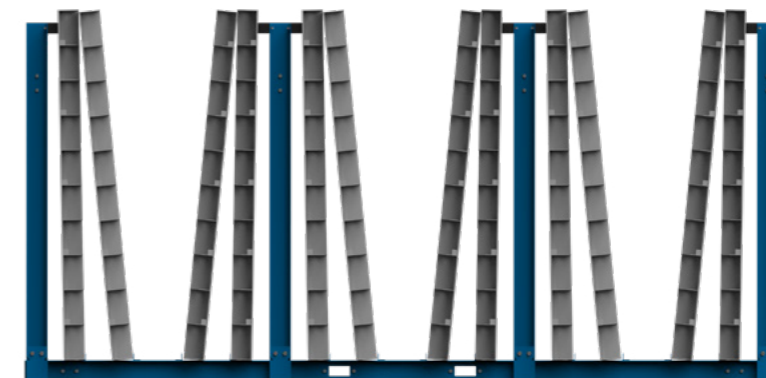
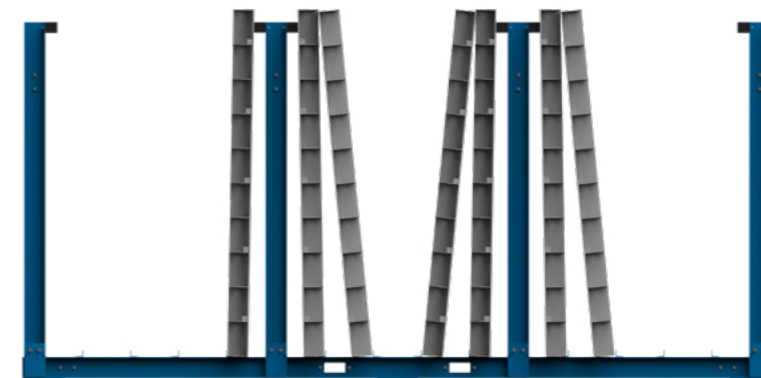

UNLOADING THE RACK

01. When you have finished using the Formwork Rack for storage, unload the formwork panels and equipment carefully and sequentially from the outside into the centre, to avoid uneven loading and prevent instability.

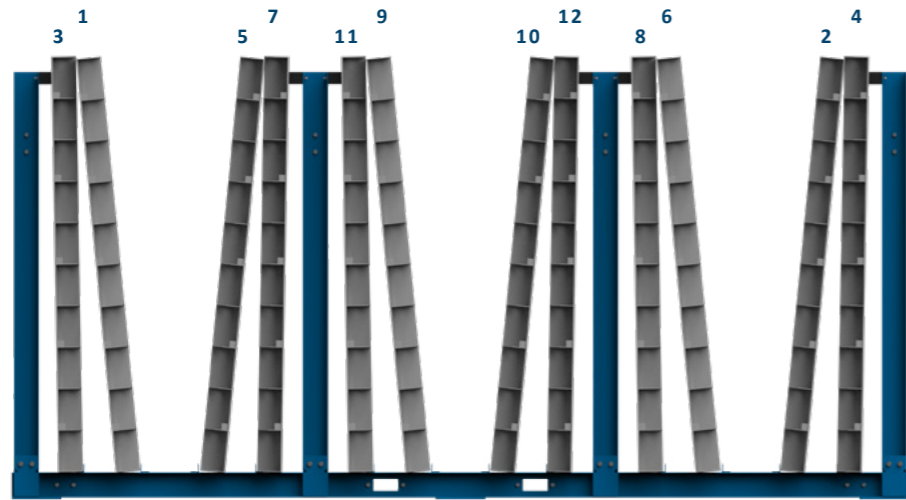

02. Transport the Formwork Rack to its new location using suitable lifting equipment or forklift/telehandler.



PANEL COMPATIBILITY

Warning: Please note, the below compatibility data should only be used as guidance. Prior to loading the rack, it is the responsibility of the user to ensure the necessary checks have been completed by qualified personnel.

The live combined panel and wind load (A) acting on each upright on the Formwork Rack must not surpass 7.5kN (15kN per upright pair) for ST127AA-05400 or 4kN (8kN per upright pair) for ST127AB-05400.

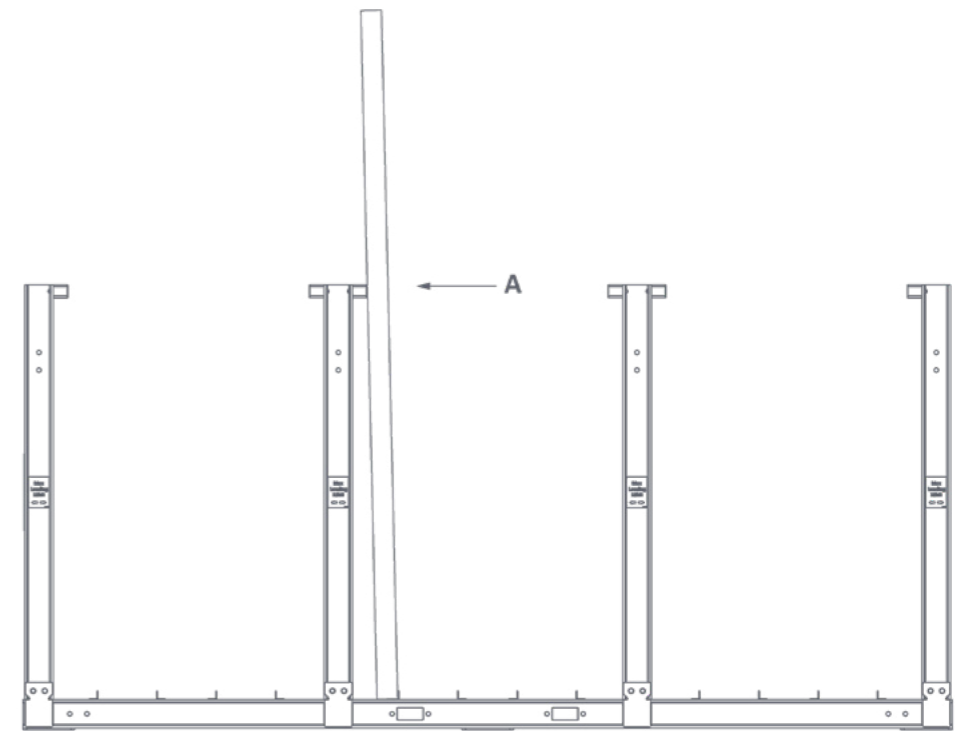

The maximum dimensions of formwork panels suitable for storage are dependent on their mass per unit area and are represented by their ratio of length to height, or height to length. The graphs on the next two pages will determine whether the formwork panels you plan to store are compatible with the Formwork Rack you have on-site.

The tables underneath the graphs contain the maximum dimensions of formwork panels that can be loaded into the rack, horizontally or vertically.

However, it is the site's responsibility to ensure the Formwork Rack is loaded safely and correctly.

8KN FORMWORK RACK

- <60 kg/m²
- 61-80 kg/m²
- 81-100 kg/m²
- >100 kg/m²

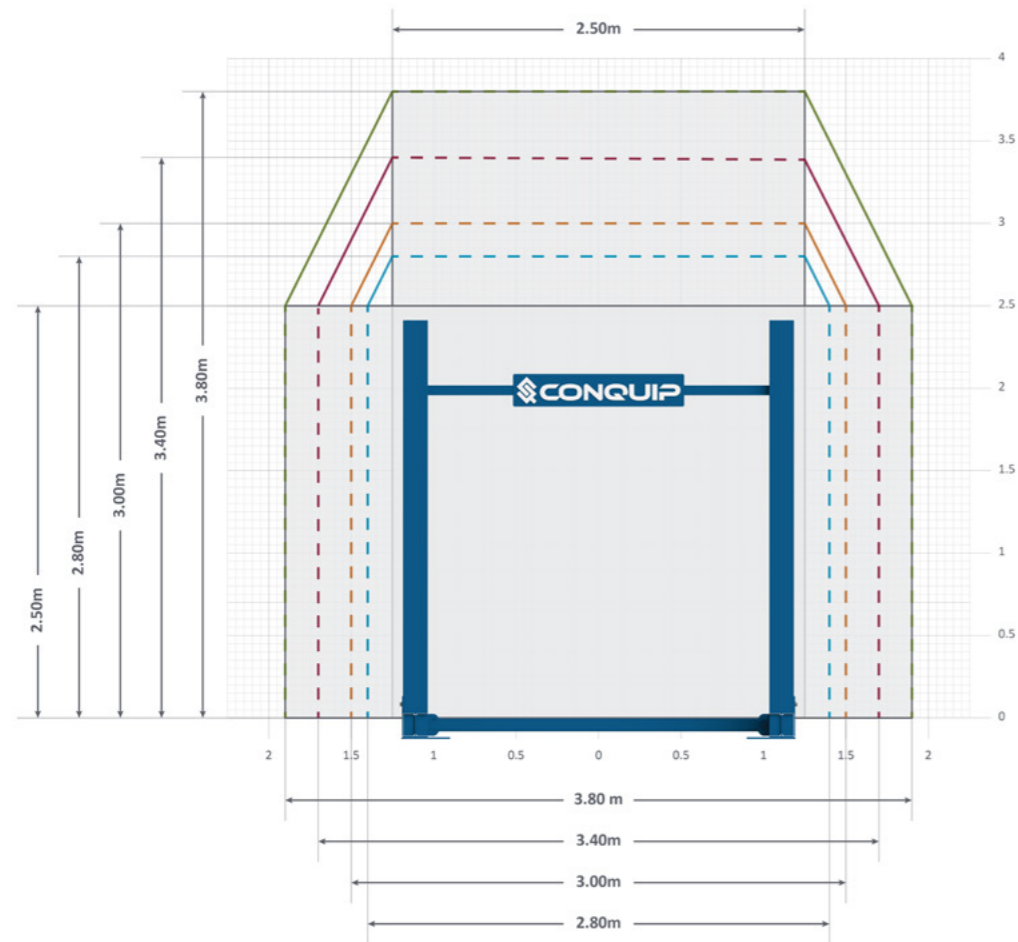

PANEL MASS PER UNIT AREA (kg/m ²)	HORIZONTAL PANEL STORAGE		VERTICAL PANEL STORAGE	
	MAX. LENGTH (m)	MAX. HEIGHT (m)	MAX. HEIGHT (m)	MAX. LENGTH (m)
<60	3.80	2.50	3.80	2.50
61-80	3.40	2.50	3.40	2.50
81-100	3.00	2.50	3.00	2.50
>100	2.80	2.50	2.80	2.50

15KN FORMWORK RACK

- <60 kg/m²
- 61-80 kg/m²
- 81-100 kg/m²
- >100 kg/m²

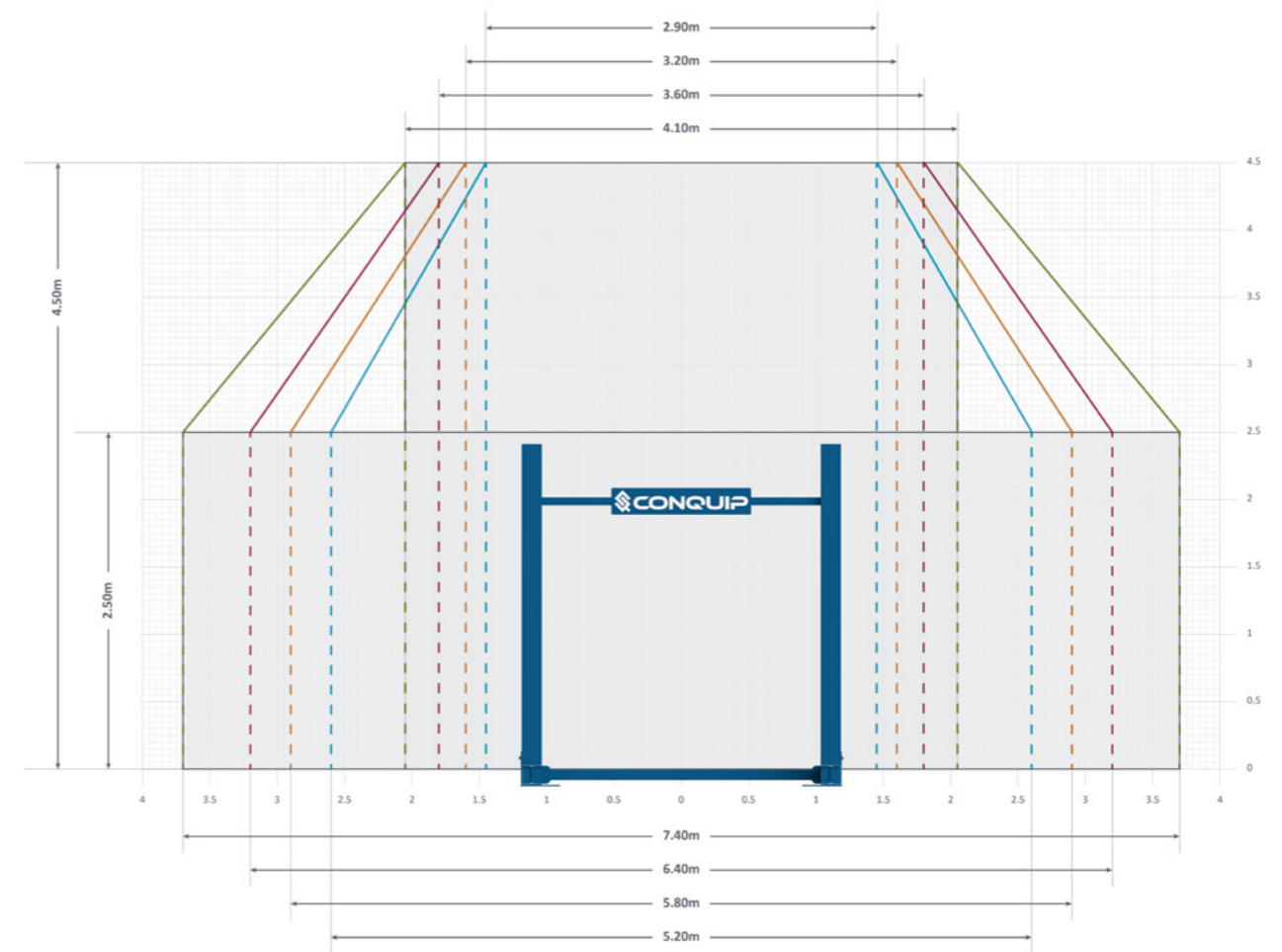

PANEL MASS PER UNIT AREA (kg/m ²)	HORIZONTAL PANEL STORAGE		VERTICAL PANEL STORAGE	
	MAX. LENGTH (m)	MAX. HEIGHT (m)	MAX. HEIGHT (m)	MAX. LENGTH (m)
<60	7.40	2.50	4.50	4.10
61-80	6.40	2.50	4.50	3.60
81-100	5.80	2.50	4.50	3.20
>100	5.20	2.50	4.50	2.90

EXAMPLE 01 - 8KN FORMWORK RACK

An assembly of formwork panels is 5.5m long x 3.3m high x 1,000kg approx. mass.

Formwork panel mass per unit area = $1000 / (3.3 \times 5.5) = 55\text{kg/m}^2$

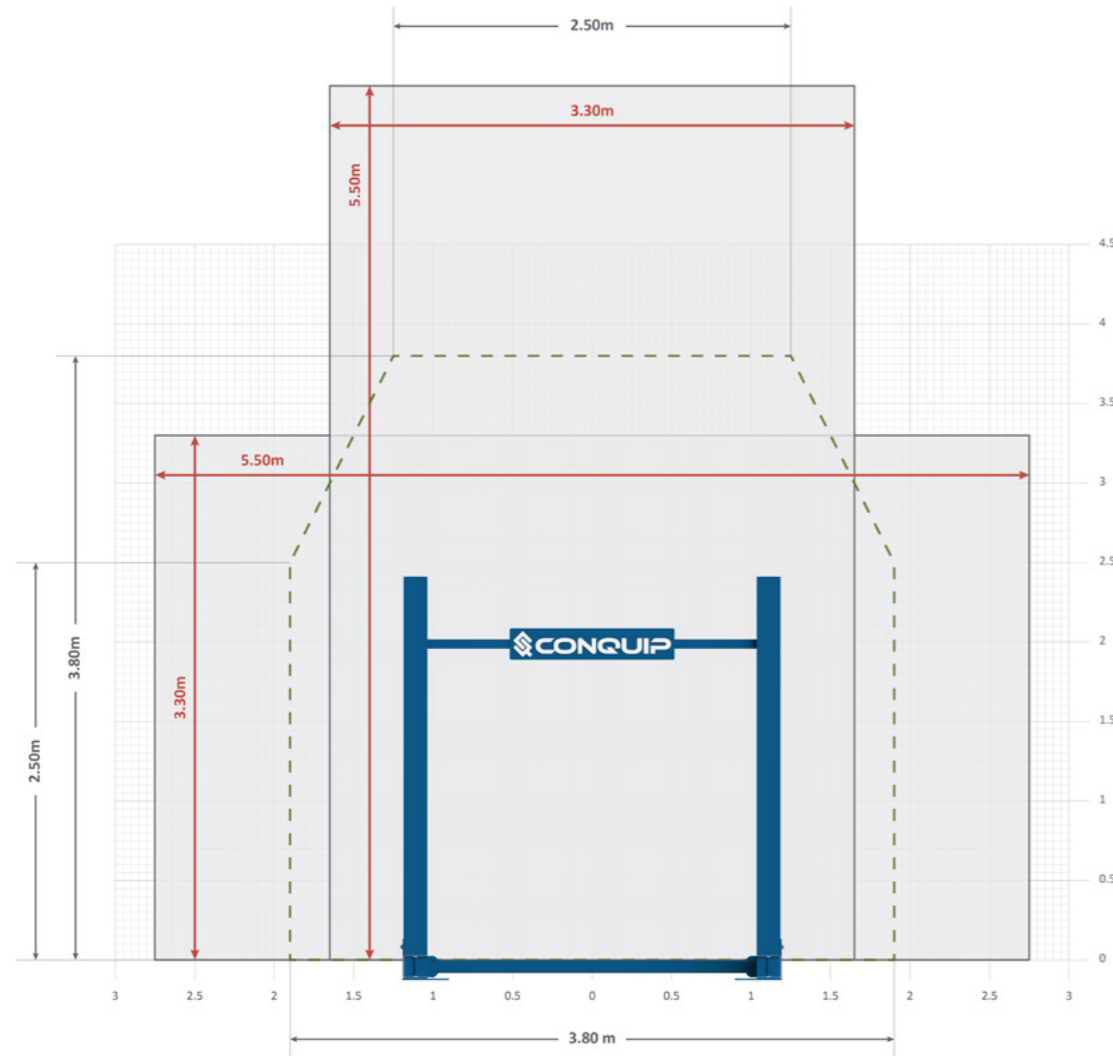

Therefore the formwork panel assembly is too large to be stored into this formwork rack, it must be disassembled into smaller panel sizes that fit within the acceptable panel area or a 15kN formwork rack can be utilised as 'Example 02' illustrates.

EXAMPLE 02 - 15KN FORMWORK RACK

An assembly of formwork panels is 5.5m long x 3.3m high x 1,000kg approx. mass.

Formwork panel mass per unit area = $1000 / (3.3 \times 5.5) = 55\text{kg/m}^2$

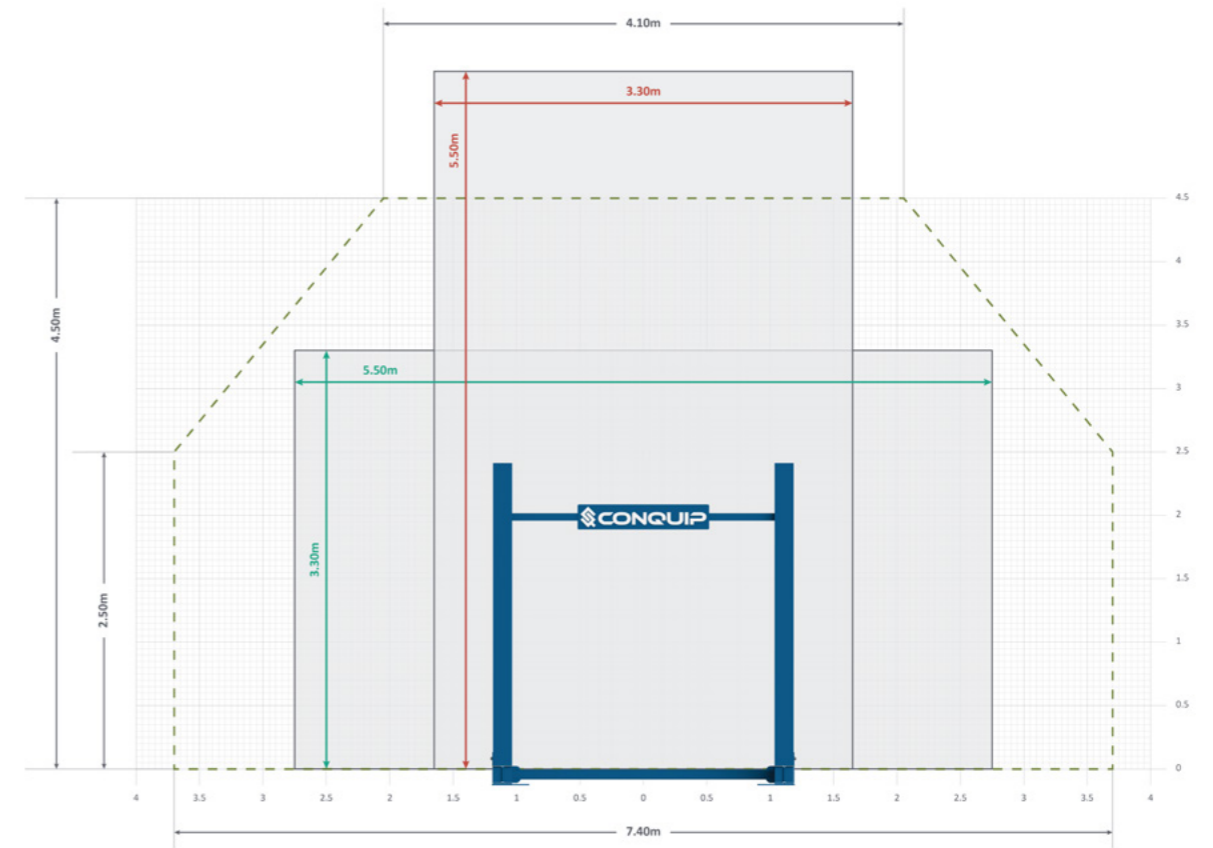

Therefore the formwork panel assembly too large to be stored on this Formwork Rack vertically as it does not fit within the acceptable panel area but it can be stored if it is laid horizontally.

If you have an application which is outside the limitations of the Formwork Rack, then please contact Conquip Engineering if you require any further assistance.

MAINTENANCE & INSPECTION

MAINTENANCE REGIME

- It is mandatory that the equipment is thoroughly examined regularly, by a qualified engineer, to ensure compliance with relevant regulations. Conquip recommend carrying out a thorough examination every six months.
- This equipment may incorporate various loose and detachable items including, but not limited to pins, bolt assemblies and adaption plates. Refer to the separate requirements for the safe use of those items.
- When not being used, store the unit in a clean, upright condition and in a safe place where it will be protected from thieves and unauthorised users.
- This equipment must be inspected by the responsible person before each use and then regularly, as determined by your risk assessment or working practice. If you have any concerns about the equipment's condition or suitability, do not use it.

VISUAL INSPECTION CHECKLIST

INSPECTION ITEMS	RESULTS		COMMENTS
	SATISFACTORY	UNSATISFACTORY	
Serial Number			CQ.....
Product Code			
Working Load Limit (kg)			
Conforms to user guide specification			
Condition of rubber buffers			
Uprights bent or distorted			
Stops on lower beams bent or distorted			
Condition of lifting points			
Condition of fork pockets			
General visual framework inspection			
SIGNATURE			
Name	Position	Qualification	Signature & Date

GENERAL SAFETY INSTRUCTIONS

The equipment should be properly operated and maintained to keep it in a safe, efficient operating condition. Be sure that all fixings and components are free of mud or other matter that might cause issues hazardous to the operator, serviceman, or other personnel or equipment. Report all malfunctions to those responsible for maintenance, and do not operate the equipment until corrected. Normal service or maintenance performed as required can prevent unexpected and unnecessary downtime.

This operations manual describes general inspections, servicing and operation with the normal safety precautions required for normal servicing and operating conditions. It is not a guide, however, for abnormal conditions or situations, and therefore, servicemen and operators must be safety conscious and alert to recognise potential servicing or operating safety hazards at all times, and take necessary precautions to assure safe servicing and operation of the equipment.



M002
Refer to instructions manual



M004
Wear eye protection



M008
Wear safety footwear



M009
Wear protective gloves



M010
Wear protective clothing



M014
Wear head protection



M015
Wear high-visibility clothing

GENERAL NOTES

- Read this operations manual and learn the operating characteristics and limitations of the equipment. Know what operating clearances the machine requires.
- Read and understand all the safety signs prior to operation.
- If the safety signs are obstructed by dirt or debris, clean them using mild soap and water prior to operation.
- If the safety signs are damaged or illegible, replace them immediately, prior to operation.
- Be aware of operating hazards that weather changes can create on the job. Know proper procedures to follow when a severe rain or electrical storm strikes.
- Never attempt to operate or work on machinery when not feeling physically fit.
- Never wear loose clothing, rings, watches, heavy gloves etc., that might catch and result in injury.
- Know what safety equipment is required and use it. Such equipment may be: hard hat, safety glasses, reflector type vests, protective gloves and safety footwear.

TERMS & CONDITIONS

CONQUIP ENGINEERING GROUP STANDARD PRODUCT WARRANTY

01. COMMENCEMENT

1.1 This Warranty shall commence on the Commencement Date and shall continue until the earlier of:

- (a) the Expiry Date; or
- (b) the date on which it may be voided in accordance with clause 4.1(b)

when it shall terminate automatically without notice.

02. DUTY OF GOOD FAITH

2.1 The Purchaser shall in the exercise of its rights under this Warranty and in the compliance with its obligations under this Warranty be subject to and shall in all respects owe and comply with a duty of good faith to the Warrantor.

03. NATURE AND EXTENT OF COVER

3.1 Subject to clause 3.2 the Warrantor agrees and undertakes to the Purchaser that it shall be liable to the Purchaser under and in accordance with the terms of this Warranty in the event that:

- (a) prior to the Expiry Date the Purchaser shall notify a Warranty Claim to the Warrantor; and
- (b) the Equipment or any relevant part of the Equipment shall have become unusable as the result of defective material or defective workmanship prior to the Expiry Date.

3.2 The Warrantor's obligation under clause 3.1 shall be expressly subject to the provisions of clauses 4, 5 and 6 and conditional upon the Purchaser's compliance in full with the provisions of clause 7.

04. RESTRICTIONS

4.1 The following restrictions apply to this Warranty:

(a) This Warranty is personal to the Purchaser and neither the legal benefit nor legal burden of this warranty may be assigned or novated or otherwise transferred by the Purchaser to any other party. Any purported assignment, novation or transfer shall not be binding upon the Warrantor.

(b) This Warranty shall be void in the event that the Purchaser:

(i) cannot provide authentic and original documentary evidence that the Purchaser has during the period between the Commencement Date and the Expiry Date complied with the Maintenance and Servicing Requirements; and/or

(ii) has, during the period between the Commencement Date and the Expiry Date, exceeded the Purchaser's Usage Cycle Parameters; and/or

(iii) has, during the period between the Commencement Date and the Expiry Date, exceeded the Purchaser's Use Parameters; and/or

(iv) has carried out, or procured the carrying out by any third party of, any repair to the Equipment or any part of the Equipment which is not an Authorised Repair; and/or

(v) has operated the Equipment after having replaced any part of the Equipment with a part which has not been supplied and fitted by the Warrantor; and/or

(vi) has modified the Equipment in any way prior to use.

05. EXCLUSIONS

5.1 The following are excluded from the scope of this Warranty:

(a) Loss of and/ or damage to the Equipment or any part of it resulting from any collision between the Equipment and any other fixed or stationary or mobile object whatsoever, irrespective of whether that collision was or was not caused by the Purchaser; and/or

(b) Loss of and/or damage to any personal property and/or possessions or other equipment not forming part of the Equipment but which is present in or about the Equipment; and/or

(c) loss and/or damage which is covered by any other insurance policy taken out and maintained by the Purchaser or in respect of which the Purchaser has a contractual obligation to do so; and/or

(d) loss and/or damage to the equipment which is consistent with the use by the Purchaser of the Equipment:

(i) in compliance with the Maintenance and Servicing Requirements; and

(ii) in compliance with the Usage Cycle Parameters; and

(iii) in compliance with the Use Parameters; and

(iv) having only carried out Authorised Repairs to the Equipment; and

(v) having all and any replacement parts fitted by the Warrantor; and

(vi) in unmodified form.

06. LIMITATION OF LIABILITY

6.1 The Warrantor's liability to the Purchaser shall be limited as follows:

- (a) The Warrantor shall not in any circumstances be liable to the Purchaser for indirect and/or consequential and/or economic loss suffered and/or incurred as the case may be by the Purchaser; and
- (b) The Warrantor shall only be liable to the Purchaser for the reasonable and proper costs reasonably and properly incurred by the Purchaser directly in connection with the repair and/or replacement (at the Warrantor's absolute discretion) of the Equipment or any part of the Equipment; and
- (c) The Warrantor's liability to the Purchaser shall notwithstanding any other provision of this Warranty, not in any circumstances exceed the Purchase Price of the Equipment.

07. WARRANTY CLAIMS

7.1 The Purchaser shall in respect of any claim against the Warrantor under this Warranty and within 24 hours of the occurrence of the subject matter of the Warranty Claim:

- (a) Complete in full and submit to the Warrantor a Warranty Claim in the form annexed to Schedule 4;
- (b) Provide date stamped or date identifiable photographs evidencing the claim; and
- (c) Make the Equipment or the relevant part of the Equipment available to the Warrantor for inspection within 48 hours of notification of the relevant Warranty Claim.

08. ENTIRE AGREEMENT

8.1 This Warranty constitutes the entire agreement between the parties and supersedes and extinguishes all previous promises, assurances, warranties, representations and understandings between them, whether written or oral, relating to its subject matter.

8.2 Each party agrees that it shall have no remedies in respect of any statement, representation, assurance or warranty (whether made innocently or negligently) that is not set out in this Warranty. Each party agrees that it shall have no claim for innocent or negligent misrepresentation or negligent misstatement based on any statement in this Warranty.

No variation of this Warranty shall be effective unless it is in writing and signed by the parties (or their authorised representatives).

09. WAIVER

No failure or delay by a party to exercise any right or remedy provided under this Warranty or by law shall constitute a waiver of that or any other right or remedy, nor shall it prevent or restrict the further exercise of that or any other right or remedy. No single or partial exercise of such right or remedy shall prevent or restrict the further exercise of that or any other right or remedy.

10. SEVERANCE

10.1 If any provision or part-provision of this Warranty is or becomes invalid, illegal or unenforceable, it shall be deemed deleted, but that shall not affect the validity and enforceability of the rest of this Warranty.

10.2 If any provision or part-provision of this Warranty is deemed deleted under clause 10.1 the parties shall negotiate in good faith to agree a replacement provision that, to the greatest extent possible, achieves the intended commercial result of the original provision.

11. THIRD PARTY RIGHTS

11.1 This Warranty does not give rise to any rights under the Contracts (Rights of Third Parties) Act 1999 to enforce any term of this Warranty.

12. GOVERNING LAW

12.1 This Warranty and any dispute or claim (including non-contractual disputes or claims) arising out of or in connection with it or its subject matter or formation shall be governed by and construed in accordance with the law of England and Wales.

13. JURISDICTION

13.1 Each party irrevocably agrees that the courts of England and Wales shall have exclusive jurisdiction to settle any dispute or claim (including non-contractual disputes or claims) arising out of or in connection with this Warranty or its subject matter or formation.

DESIGN CONFORMITY (EC & UK)

- (01) This certificate meets the requirements of the Machinery Directive 2023/42/EC of the European Parliament and Council.
- (02) This certificate meets the requirements of the Supply of Machinery (Safety) Regulations 2008.

DETAILS

NAME & ADDRESS OF MANUFACTURER:
Conquip Engineering Group Ltd, Unit 4, Waterbrook Estate, Alton, Hampshire. GU34 2UD
NAME & ADDRESS OF PERSON TO COMPILE TECHNICAL FILE:
Name: Daniel Critchley Address: Conquip Engineering Group, Unit 4, Waterbrook Estate, Alton, Hampshire. GU34 2UD
NAME & ADDRESS OF AUTHORISED REPRESENTATIVE IF ONE HAS BEEN MANDATED BY THE MANUFACTURER:
N/A
NAME, ADDRESS, AND IDENTIFICATION NUMBER OF THE NOTIFIED BODY (01) OR APPROVED BODY (02), WHERE APPLICABLE:
N/A

EQUIPMENT DESCRIPTION

PRODUCT CODE(S)	GENERAL DESCRIPTION	WORKING LOAD LIMIT
ST127AA-05400	15kN Formwork Rack	Self Weight
ST127AB-05400	8kN Formwork Rack	Self Weight

HARMONISED STANDARDS & REGULATIONS

ITEM	CODE	DESCRIPTION
EC DIRECTIVE/REGULATION	2023/42/EC	Directive 2023/42/EC- new machinery directive
HARMONISED STANDARDS	BS EN ISO 12100:2010	Safety of machinery General principles for design Risk assessment and risk reduction
OTHER REGULATIONS	LOLER 1998	Lifting Operations and Lifting Equipment Regulations 1998 (LOLER)
	PUWER 1998	Provision and Use of Work Equipment Regulations 1998 (PUWER)

DECLARATION

PLACE OF DECLARATION:
Alton
DATE OF DECLARATION:
October 2025

I declare that the above equipment meets the Essential Health and Safety requirements of the
 (01) Machinery Directive 2023/42/EC of the European Parliament and Council.
 (02) Supply of Machinery (Safety) Regulations 2008 and Section 6 of the Health and Safety at Work Etc. Act 1974.

NAME:	POSITION:	SIGNATURE:
Daniel Critchley	Managing Director	

TALKING TO US IS EASY
WE'RE HERE TO HELP

Call us on 0333 300 3470
Email us at sales@cqegroup.com
www.cqegroup.com

