

USER GUIDE

# CONCRETE WASHOUT SYSTEM

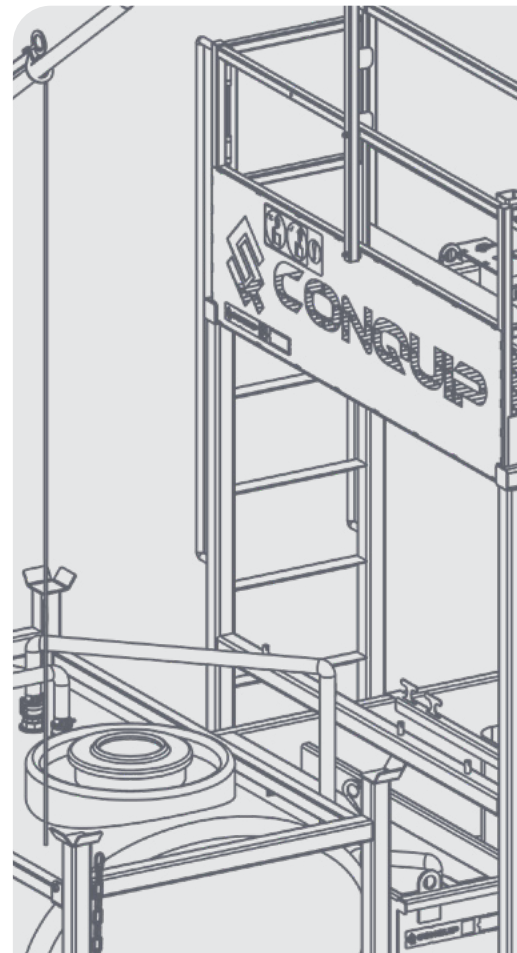

# DISCLAIMER

Do not attempt to handle or operate this equipment before you have received sufficient training. Before use, operatives must have carried out all checks featured on the Visual Inspection Sheets on pages 25 to 27. It is imperative that you have read the General Safety Instructions on page 28 and sufficiently familiarised yourself with the Operational Procedures in this document.

Note that this item is compliant only to the standards specified in this User Guide and it is therefore the duty of the responsible person(s) to review and ensure compliance.

# CONTENTS

## PRODUCT INFORMATION

INTRODUCTION	04
SPECIFICATION	05
PARTS DIAGRAM	09

## OPERATIONAL PROCEDURES

IMPORTANT USAGE NOTES	14
ASSEMBLY INSTRUCTIONS	14
USAGE INSTRUCTIONS	20

## MAINTENANCE & INSPECTION

MAINTENANCE REGIME	24
VISUAL INSPECTION SHEET	25

## GENERAL SAFETY INSTRUCTIONS

SAFETY INSTRUCTIONS	28
GENERAL NOTES	29

## LEGAL

TERMS AND CONDITIONS	30
EC DESIGN CONFORMITY	34
STANDARDS AND REGULATIONS APPLICABLE	35

# INTRODUCTION

## OVERVIEW

The [Conquip Concrete Washout System](#) is a complete, best practice solution for concrete washout. It is a unique, compact, simple system, which enables sites to reuse the water from cleaning concrete skips, pumps and trucks.

The system is made up of three components; a filtration tray, a skip washing platform and a water storage tank. The platform features resting pads for landing smaller skip sizes, making it compatible with any 500 to 3000-litre Conquip Concrete Skip. Various filtration bag arrangements in the tray accommodate cleaning other concrete equipment, including pumps and truck chutes.

During washout, filtration bags capture the large concrete aggregate and as the wastewater passes through the filtration holes. Larger sediment is filtered out before the water passes back into the storage tank, ready to be used again. After washout is complete, the concrete wastewater can be pumped into the storage tank and further treated with pH neutralising solution.

The Concrete Washout System is an innovative approach to reusing concrete wastewater that is safe, easy to use and improves a site's environmental footprint.

## KEY BENEFITS

- Complete environmentally-friendly methodology for concrete washout and reusing concrete wastewater.
- Versatile solution suitable for washing concrete skips, pumps and trucks.
- Compact, space saving system.
- Large Skip Washing Platform compatible with the 500-3000-litre Conquip Concrete Skips.
- Small Skip Washing Platform compatible with 500-2000-litre Conquip Concrete Skips.
- Harness attachment point to keep operative on the work platform safe.
- Large sediment is filtered out before it is transferred back into the storage tank.
- 25kg containers of pH neutraliser additive are available to treat concrete wastewater collected in the water storage tank. See General Safety Instructions on page 29 for details of the Material Safety Data Sheet (MSDS) for the pH neutraliser additive.
- The pH balance of the water in the storage tank can be monitored using the pH level test kits available to purchase with the unit and corrected with pH neutraliser additive.

# SPECIFICATION

## THE SYSTEM

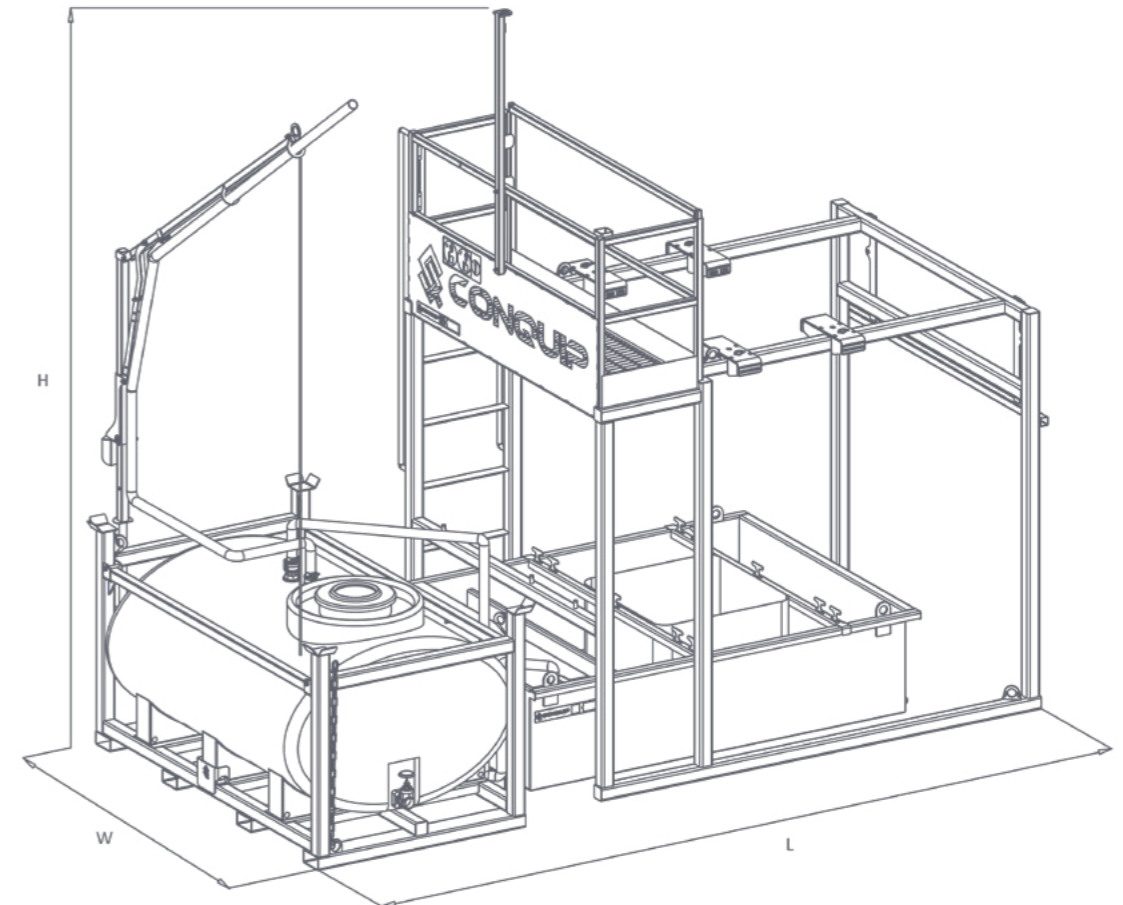

CODE	LENGTH (mm)	WIDTH (mm)	HEIGHT (mm)	WEIGHT (kg)
CS243	4600	2693	4395	1536

# SPECIFICATION

## FILTRATION TRAY

ITEM	PRODUCT CODE
Filtration Tray	CS236AE-01800

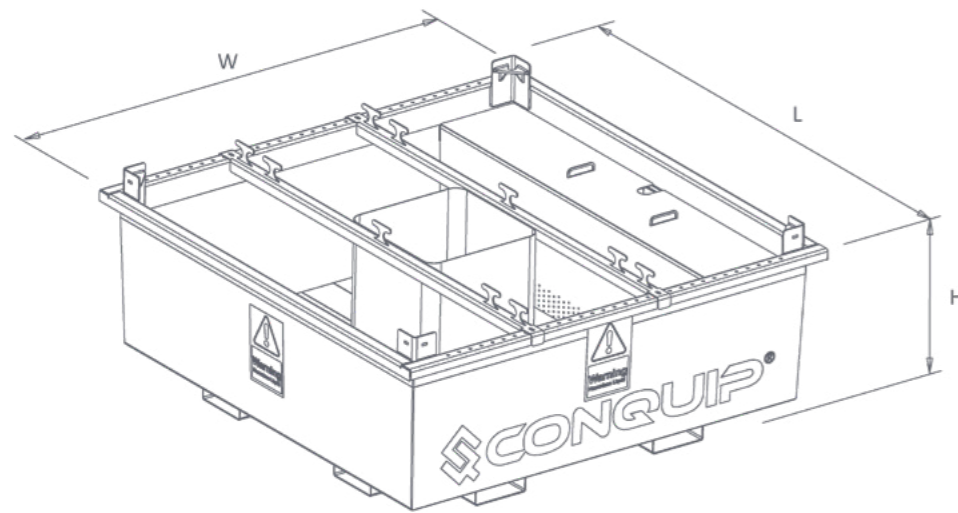

LENGTH (mm)	WIDTH (mm)	HEIGHT (mm)	WEIGHT (kg)	WLL* (kg)	CAPACITY (litres)
1900	1885	802	376	1000	1800

\*Working Load Limit

# SPECIFICATION

## WATER STORAGE TANK

ITEM	PRODUCT CODE
Water Storage Tank	FB306-02000

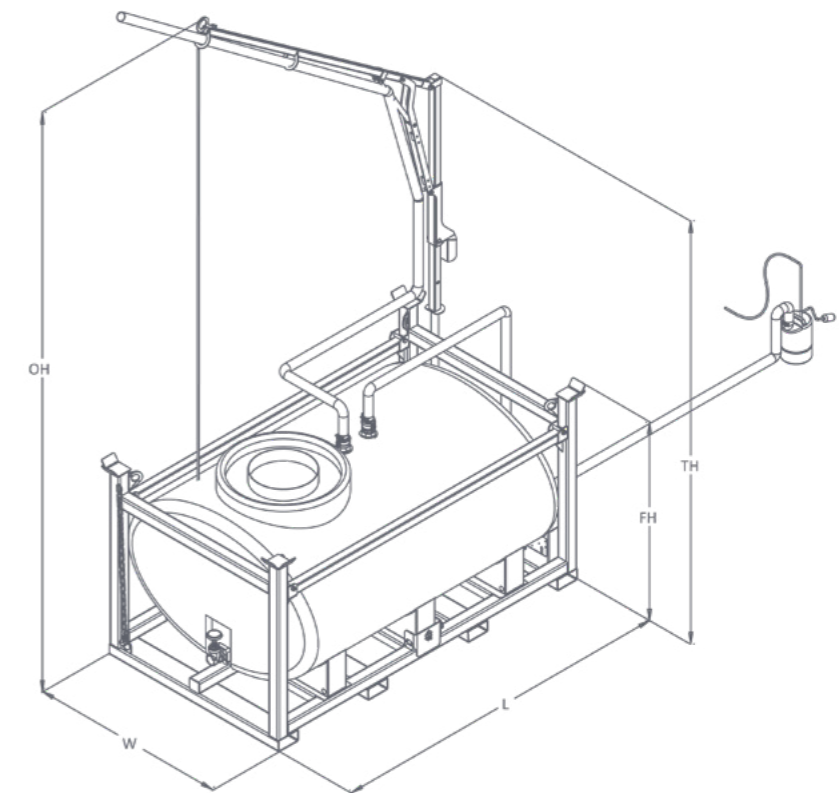

LENGTH (mm)	WIDTH (mm)	OVERALL HEIGHT (mm)	FRAME HEIGHT (mm)	WEIGHT (kg)	WLL* (kg)
2593	1500	2900	1333	570	2000

\*Working Load Limit

# SPECIFICATION

## SKIP WASHING PLATFORM

ITEM	PRODUCT CODE
Large Skip Washing Platform	CS241
Small Skip Washing Platform	CS231

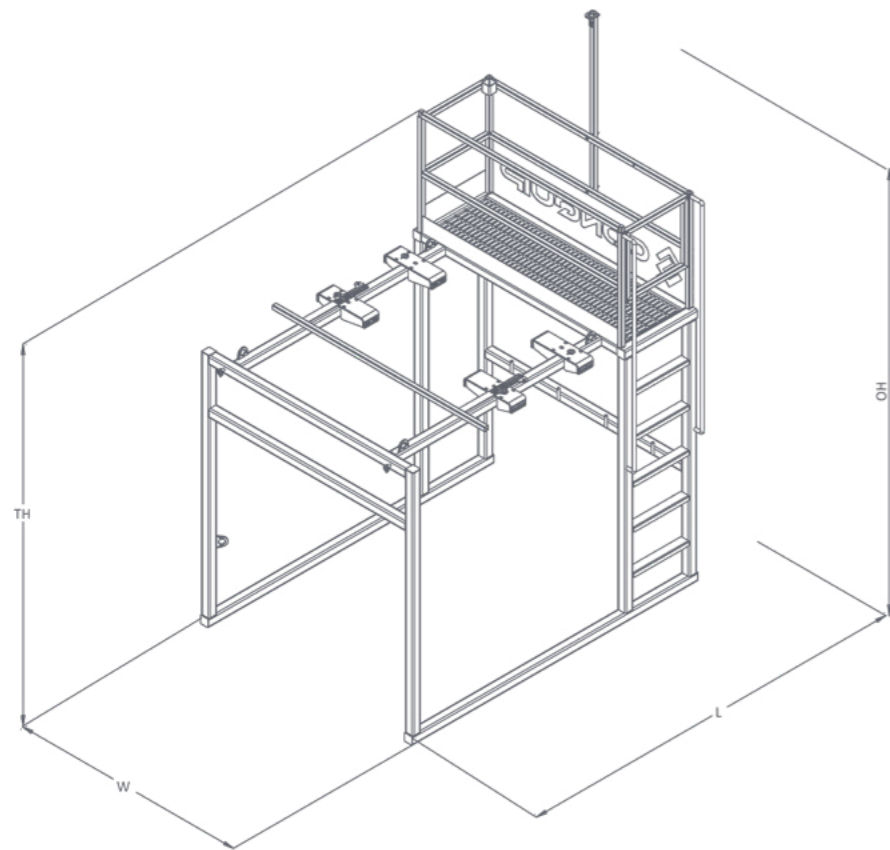

TYPE	LENGTH (mm)	WIDTH (mm)	OVERALL HEIGHT (mm)	TRANSPORT HEIGHT (mm)	WEIGHT (kg)
Large	2910	2210	4395	3374	580
Small	2455	2100	3215*	2475	450

\*The Small Skip Washing Platform must be used with a supporting upstand . This increases the overall height by 860mm to 4075mm.

# PARTS DIAGRAM

## FILTRATION TRAY

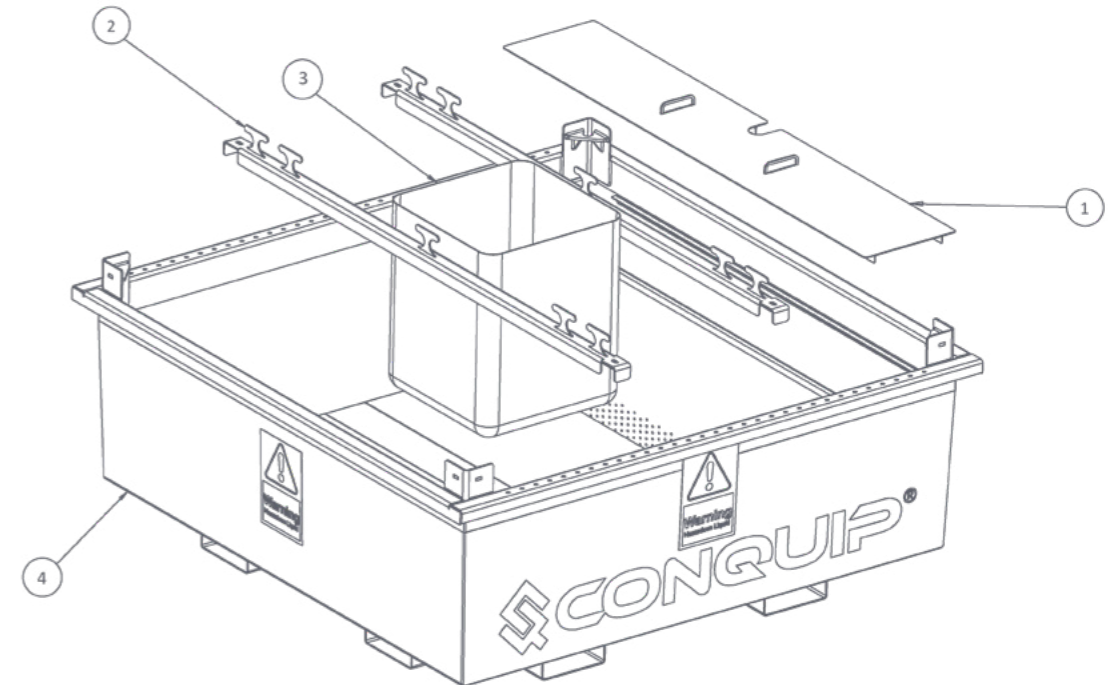

ITEM NUMBER	PART	DESCRIPTION	QUANTITY
1	ZZ120232	Pump Chamber Cover Plate	1
2	ZZ120223	Bulk Bag Rail	2
3	ZZ960046	Filter Bag	1
4	CS236AE-01800	Tray Body	1

NOTE: These parts are for this model, they may differ for previous versions. Please contact Conquip with any queries.

# PARTS DIAGRAM

## WATER STORAGE TANK

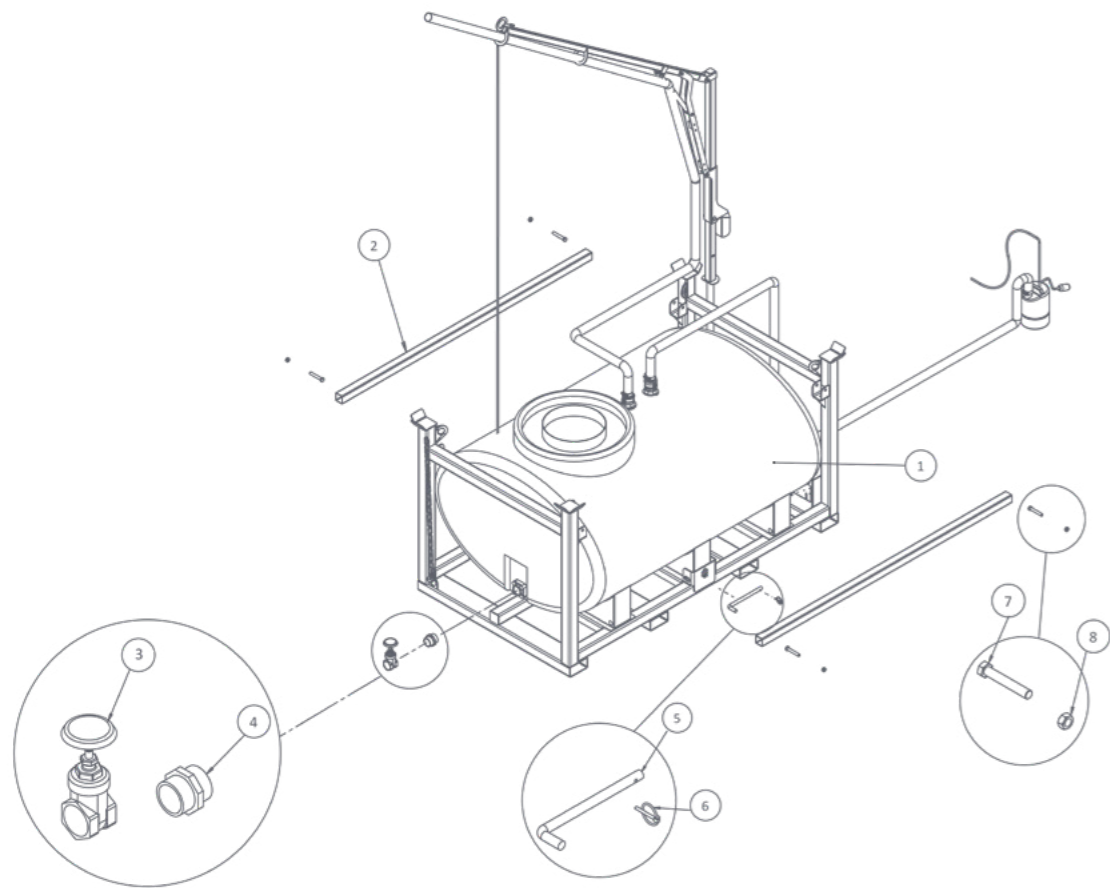

ITEM NUMBER	PART	DESCRIPTION	QUANTITY
1	ZZ990461	2000 litre Horizontal Transport Tank	1
2	ZZ120226	Removable Spreader / Retaining Bar	2
3	ZZ990468	Stopcock Valve BSP 2" Female	1
4	ZZ990469	2" Nipple (Connector) UPVC	1
5	ZZ410015	20mm Heel Pin	2
6	ZZ990009	6mm Linch Pin	3
7	NS800835	M16 x 100 Set Screw	4
8	NS800380	M16 Full Nut	4

NOTE: These parts are for this model, they may differ for previous versions. Please contact Conquip with any queries.

# PARTS DIAGRAM

## WATER STORAGE TANK

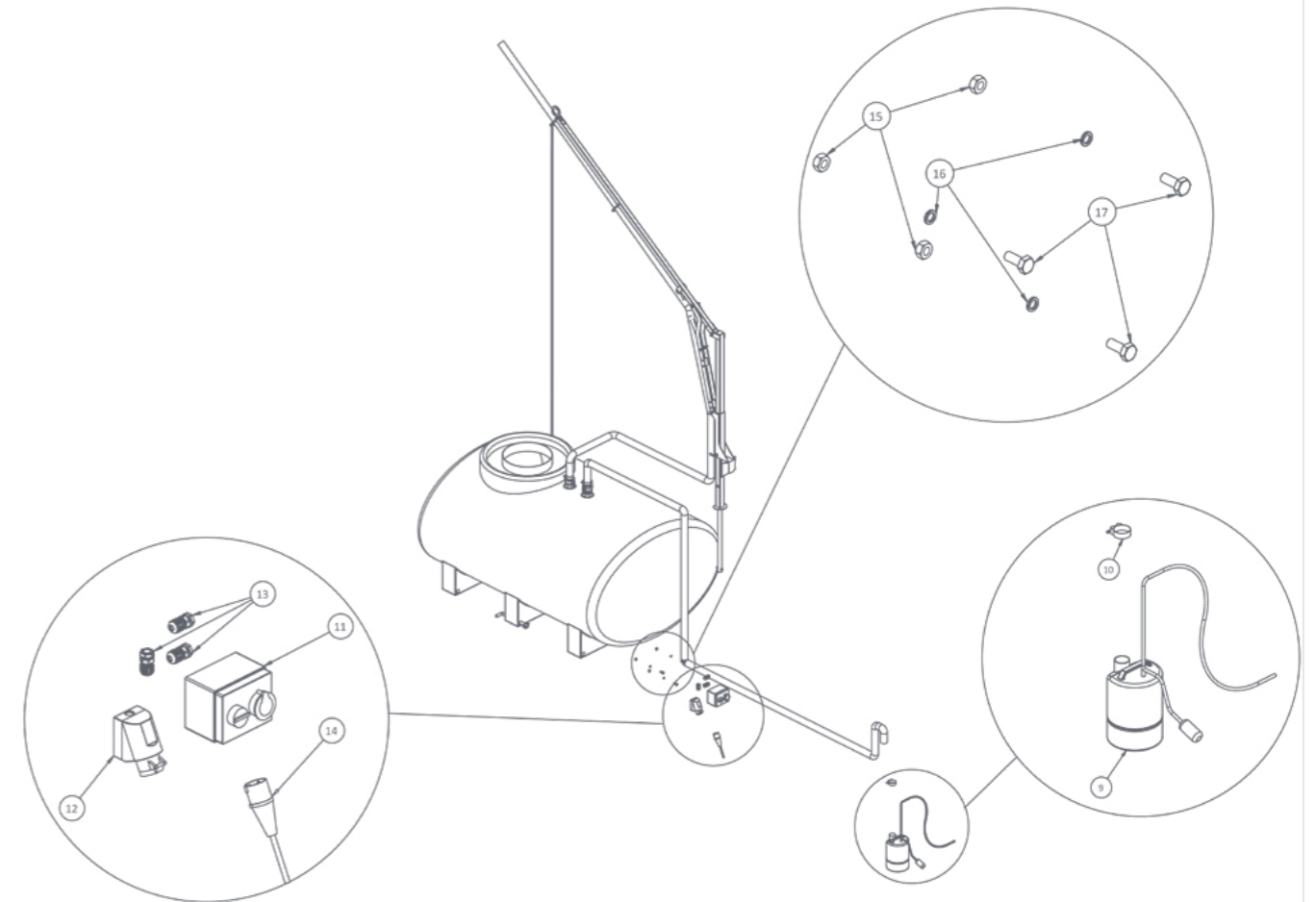

9	ZZ990457	Submersible Pump	2
10	ZZ990459	Hose Clamp for 2" Hose	5
11	ZZ990473	Switched Power Socket 110V 16A	1
12	ZZ990474	Unswitched Power Socket 110V 16A	1
13	ZZ990476	M20 Plastic Cable Gland	3
14	ZZ990475	Lead 14m 110V 16A	1
15	NS800017	M10 Full Nut	3
16	NS800396	M10 Spring Washer	3
17	NS800063	M10 x 25 Hex Head Set Screw	3

NOTE: These parts are for this model, they may differ for previous versions. Please contact Conquip with any queries.

# PARTS DIAGRAM

## WATER STORAGE TANK

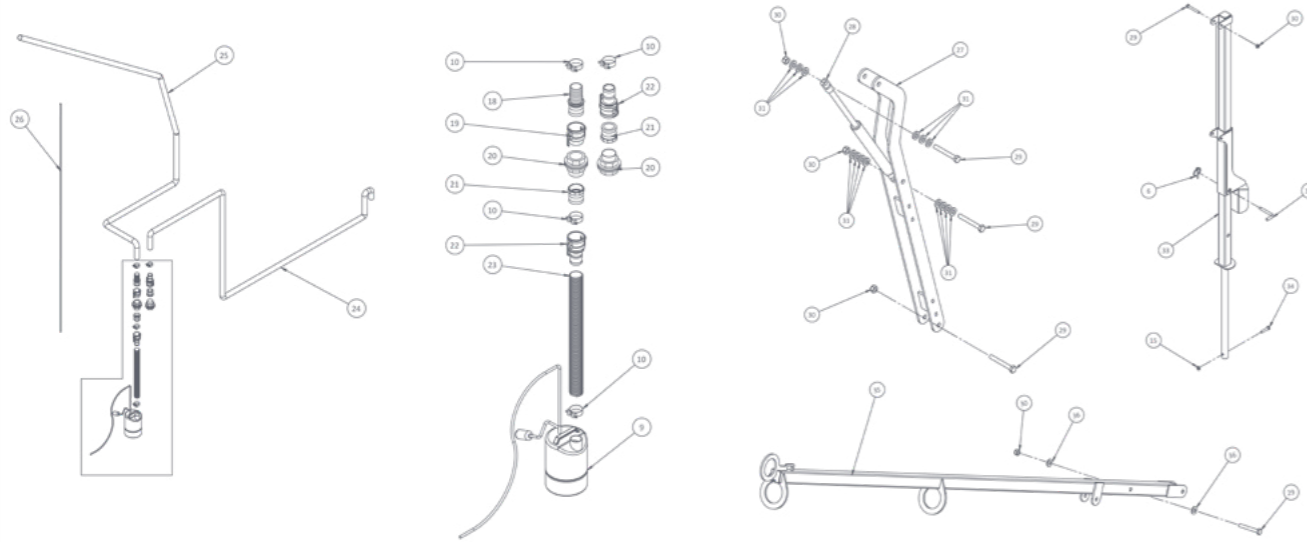

ITEM NUMBER	PART	DESCRIPTION	QUANTITY
18	ZZ990492	Camlock Coupling Alu 2" Male to Hosetail BSP	1
19	ZZ990493	Camlock Coupling Alu 2" Female to Male BSP	1
20	ZZ990472	Plastic 2" Tank Connector	2
21	ZZ990471	Camlock Coupling Alu 2" Male to Female BSP	2
22	ZZ990470	Camlock Coupling Alu 2" Female to Hosetail BSP	2
23	ZZ990458	Superelastic PVC Hose 620mm	1
24	ZZ990458	Superelastic PVC Hose 5380mm	1
25	ZZ990458	Superelastic PVC Hose 6000mm	1
26	ZZ120029	Transportation/Holding Rope 3m	1
27	ZZ120228	Hose Gas Strut Bracket	1
28	ZZ960042	Gas Strut Fixed Force 1500N	1
29	NS800138	M10 x 100 Set Screw	5
30	NS800013	M10 Nyloc Nut	5
31	ZZ960066	M10 Washer 4mm	14
32	ZZ960068	Securing Pin	1
33	ZZ120227	Upright Hose Arm Assembly	1
34	NS800870	M10 x 60 Set Screw	1
35	ZZ120229	Long Reach Hose Arm	1
36	ZZ960067	M10 Washer 2.5mm	2

NOTE: These parts are for this model, they may differ for previous versions. Please contact Conquip with any queries.

# PARTS DIAGRAM

## SKIP WASHING PLATFORM

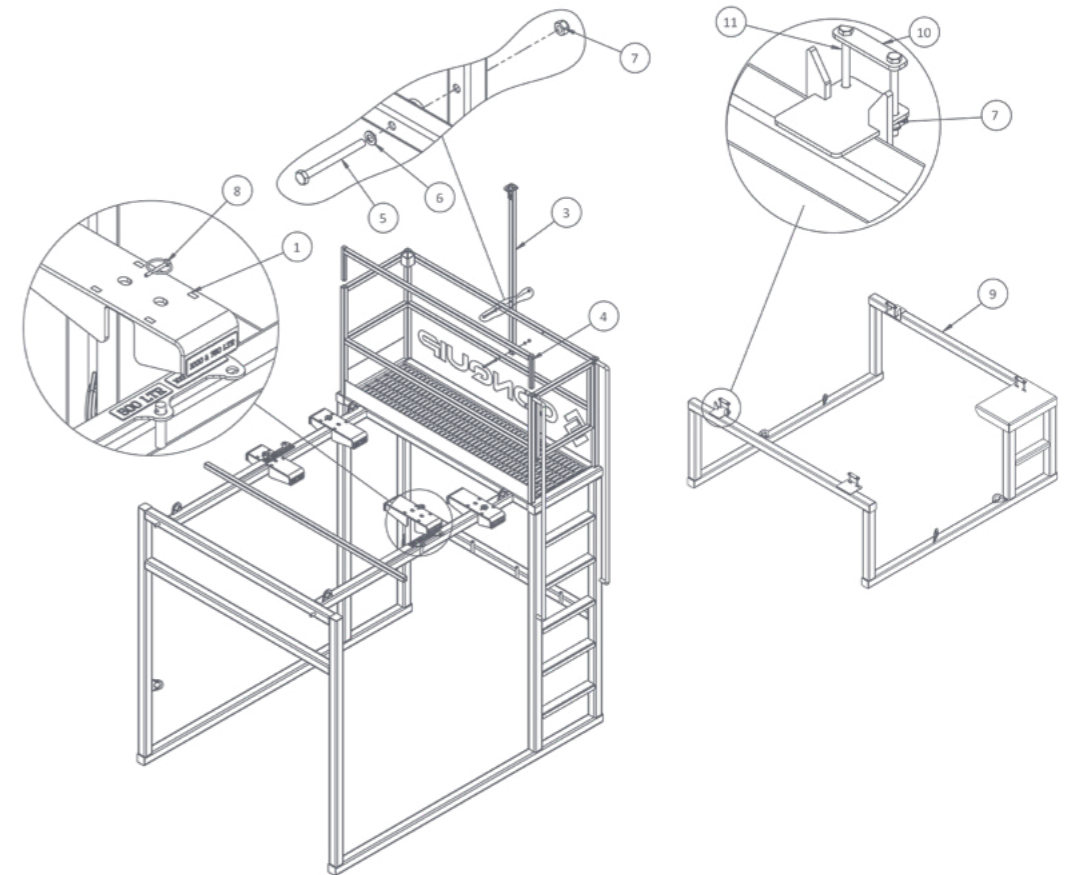

ITEM NUMBER	PART	DESCRIPTION	QUANTITY
1	ZZ120233	Adjustment Bracket	4
2	ZZ120234	Adjustment Cross Bar	1
3	ZZ120235	Harness Point	1
4	ZZ120236	Removable Handrail	1
5	NS800138	M10 x 100 Hex Head Set Screw	2
6	NS800262	M10 Washer	4
7	NS800013	M10 Nyloc Nut	10
8	ZZ990009	6mm Linch Pin	6
9	ZZ120205*	Upstand for Small Skip Washing Platform	1
10	ZZ120265	Connector plate to suit ZZ120205	4
11	NS800904	M10 x 120 Hex Head Bolt	8

\*The Upstand is only required if using the Small Skip Washing Platform.

NOTE: These parts are for this model, they may differ for previous versions. Please contact Conquip with any queries.

# OPERATIONAL PROCEDURES



## IMPORTANT USAGE NOTES

- When configuring the Skip Washing Platform for the required skip size, ensure a certified access platform for working at height is used.
- The submersible pump for the Filtration Tray will need fitting during assembly but the pump in the Water Storage Tank comes fitted with its own submersible pump inside.
- When transporting the tray with a forklift ensure the forks are fully inserted into the fork pockets, forks tilted back for maximum stability of the load.
- Ensure the harness point upright has been lowered into its transport position before the Skip Washing Platform is moved around site or relocated to another site.
- If using the Small Skip Washing Platform (CS231) and supporting upstand, lift using the lifting points at the top of the Skip Washing Platform.
- Ensure no personnel are on the Skip Washing Platform when a skip is lowered into position or lifted away. Use taglines to guide the skip from ground level.

## ASSEMBLY INSTRUCTIONS

Before starting to assemble the Concrete Washout System, ensure there is a safe and approved, 110V electricity supply, close to the designated set up area.

### FILTRATION TRAY ASSEMBLY

01. Move the Filtration Tray into position using a crane or forklift.  
If using a crane, attach a 4-leg chain to the lifting points in each corner of the tray and check the load is balanced. Then, carefully lower it into the washout area.  
If using a forklift, align the machines' forks with the fork pockets on the tray and insert them fully inside. Tilt the forks back for maximum stability of the load. Once in position, carefully lower the unit to the ground and reverse the machine away.
02. Remove the lid from the end compartment in the Filtration Tray and place the submersible pump inside. Ensure there is a float attached to the pump for identifying the water level.



03. Place the rails across the width of the tray, ensuring they are positioned wide enough to hold the filter bag open. Wrap the filter bag handles around the hooks on the rails to secure them in place.
04. If you are washing out a Concrete Skip, one filter bag will suffice. However, Conquip recommend using two or four filtration bags for washing out a concrete truck chute to capture the maximum amount of aggregate in the bags.



### LARGE SKIP WASHING PLATFORM ASSEMBLY

01. Attach certified lifting chains to the lower lifting eyes on the four legs of the Large Skip Washing Platform. Crane lift to the washout area and lower the platform over the Filtration Tray. Ensure both legs of the platform are outside the tray and that they sit level on the ground.
02. The platform can be configured to hold Conquip Concrete Skips from 500 to 3000-litre capacities. This must be carried out before attempting to lift a skip onto the platform.
03. First, identify the size of skip you have on-site. You can do this by reviewing the ID plate on the side of the unit.
04. The platform must be configured to suit the size of the skip.
05. For 500, 750 & 1000-litre skips, you need to configure the platform with four resting pads and the restraint bar. The resting pads can be adjusted by removing the linch pins, lifting the pads off and rotating them 180°, so either a smaller or larger length is overhanging into the skip holding area, depending on the size of skip. Once in place, refit the linch pins to secure the resting pads.



06. Now set up the restraint bar to match the size of the skip. Remove the restraint bar from its storage position and lower it over the lugs, using the correct hole as per the skip size. Refit linch pins as required.
07. For larger skips with sizes from 1500 to 3000-litres, the resting pads and the restraint bar are not required as these skips are large enough to rest in the platform frame.

**500-LITRE SKIPS**

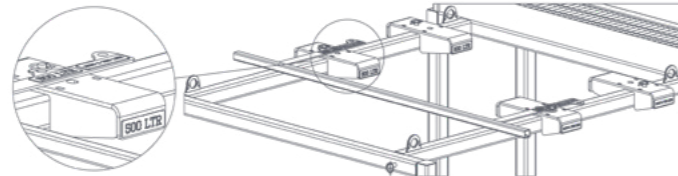

**750 & 1000-LITRE SKIPS**

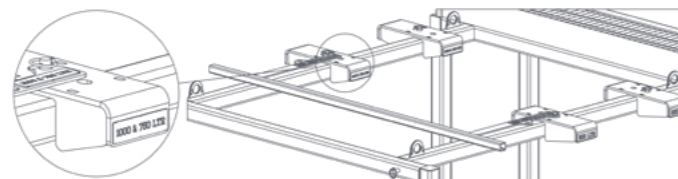

**1500-3000-LITRE SKIPS**

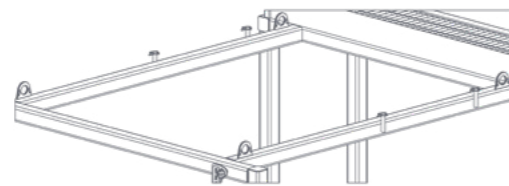

08. If the restraint bar and the resting pads are not required, they can be stored on the end of the platform and secured with their linch pins.
09. With the platform configured, the harness point upright can be moved into position. The central bolt should be loosened slightly, and the outer bolt removed completely. Swing the post upright and refit the outer bolt to fix the upright to the mid-rail. Tighten both bolts.
10. Attach the harness clip to the harness point at the top of the upright.

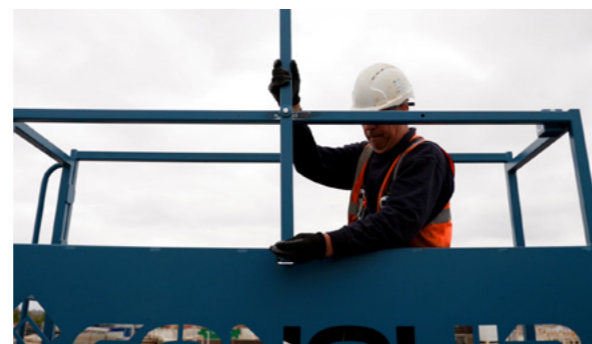

11. Once attached to the harness point, you can remove the front handrail, if required. This must only be removed if it is covered by your site risk assessment.
12. The platform is now ready for use.

**SMALL SKIP WASHING PLATFORM & UPSTAND ASSEMBLY**

01. Place the Upstand over the Filtration Tray ensuring that the two steps are on the same side as the Small Skip Washing Platform ladder.
02. Attach certified lifting chains to the lifting eyes on the top of the Small Skip Washing Platform. Crane lift the Small Skip Washing Platform over the Filtration Tray and Upstand and lower it onto the Upstand ensuring both sides of the frame slot into the 'V' shaped guides.
03. Use the cross braces and bolts to fix the Small Skip Washing Platform to the Upstand and make sure the assembly is stable and firm.



04. The platform can be configured to hold Conquip Concrete Skips from 500-litre to 2000-litre capacities. This must be carried out before attempting to lift a skip onto the platform.
05. First, identify the size of skip you have on-site. You can do this by reviewing the ID plate on the side of the unit.
06. The platform must be configured to suit the size of the skip.
07. For 500, 750 & 1000-litre skips, you need to configure the platform with four resting pads and the restraint bar. The resting pads can be adjusted by removing the linch pins, lifting the pads off and rotating them 180°, so either a smaller or larger length is overhanging into the skip holding area, depending on the size of skip. Once in place, refit the linch pins to secure the resting pads.
08. Now set up the restraint bar to match the size of the skip. Remove the restraint bar from its storage position and lower it over the lugs, using the correct hole as per the skip size. Refit linch pins as required.
09. For larger skips with sizes from 1500 to 2000-litres, the resting pads and the restraint bar are not required as these skips are large enough to rest in the platform frame.
10. If the restraint bar and the resting pads are not required, they can be stored on the end of the platform and secured with their linch pins.
11. With the platform configured, the harness point upright can be moved into position. The central bolt should be loosened slightly, and the outer bolt removed completely. Swing the post upright and refit the outer bolt to fix the upright to the mid-rail. Tighten both bolts.
12. Attach the harness clip to the harness point at the top of the upright.

13. Once attached to the harness point, you can remove the front handrail, if required. This must only be removed if it is covered by your site risk assessment.
14. The platform is now ready for use.

**WATER STORAGE TANK ASSEMBLY**

01. The Water Storage Tank sits in a steel frame with lifting points and fork pockets, allowing it to be manoeuvred around site by a crane or forklift, respectively.
02. Fill the water tank and add one 25kg container of pH neutraliser additive before manoeuvring it into position.
03. Manoeuvre the Water Storage Tank into the washout area using available lifting apparatus and position it behind or beside the platform, next to the covered compartment of the Filtration Tray.
04. Attach the hose from the Filtration Tray compartment to one of the connection couplings on the top of the Storage Tank.



05. Feed the delivery hose through the eyelets on the hose delivery arm.
06. Using two operatives, place the bottom of the hose delivery arm into the holder on the tank's



- frame. Secure with the M16 set screw and full nut.
07. Adjust the height of the hose delivery arm accordingly and secure.

08. Secure the end of the hose to the other connection coupling on top of the tank.
09. Take the black 110V power cable for the pump in the Filtration Tray and plug it into the left-hand socket on the side of the Water Storage Tank frame.



10. Then take the black 110V power cable from the pump for the Water Storage Tank and plug it into the right-hand socket on the side of the frame.
11. Finally, take the main power cable (yellow) for the Concrete Washout System and plug it into the generator / on-site power source.
12. Return to the power socket panel on the side of the Water Storage Tank frame and turn the switch on to check the water flows from the delivery hose.
13. Switch this off until you are ready to washout as the water will flow continuously.
14. The Concrete Washout System is now ready to use.



## USAGE INSTRUCTIONS

### CLEANING A CONCRETE SKIP

01. Before attempting to clean any concrete equipment using the Concrete Washout System, the washing platform must have been configured to support the relevant size of skip.
02. Follow the steps in the assembly instructions to ensure the platform has been set up correctly.
03. With the guidance of a banksman, lower the Concrete Skip onto the washing platform, ensuring the mouth of the skip is facing towards the work platform.
04. Position the skip on the platform's resting pads if using 500, 750 and 1000-litre Concrete Skips, or rest the sides of the skip on the edges of the platform for 1500, 2000 and 3000-litre skips.
05. Operatives should stand to the side of the skip washing platform and use tag lines to guide the skip and place it in position. Under no circumstances are operatives permitted to be on the work platform while a skip is mid-lift.
06. Once the skip is landed, only then can an operative climb the ladder and enter the work platform.

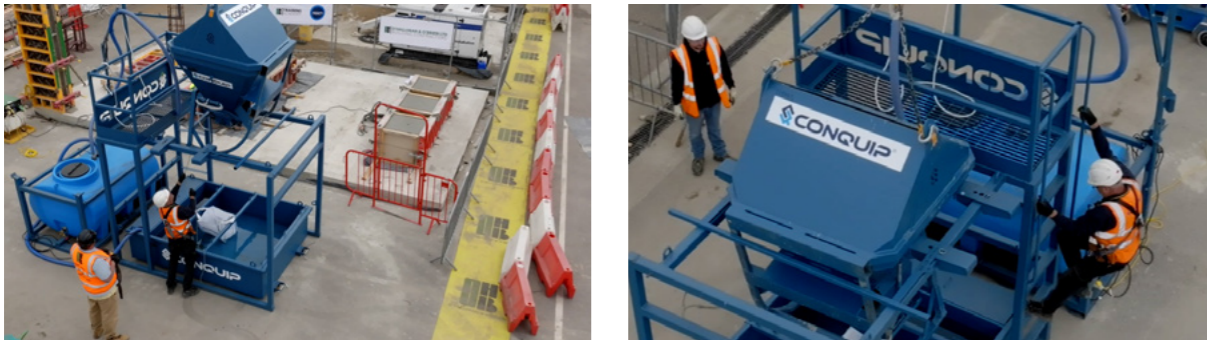

07. Once on the work platform, the operative should attach their harness to the harness point at the back of the work platform.
08. The restraint bar can then be removed from the front of the work platform and slotted into the back of the platform underneath the harness point for easier access to the skip for cleaning, subject to a site-specific risk assessment.
09. When washing a skip with a bale arm, ensure the bale arm has been lowered into the 'resting position' before attempting to clean it. For skips without bale arms, Conquip recommend placing the chains out of the way during cleaning.



10. To begin washing, turn the system on using the switch on the water storage tank frame. Once on, the water will flow continuously, so Conquip recommend an operative on ground level to control the water flow.
11. Use the delivery hose to wash all concrete off the skip. As the skip is washed, the large heavy concrete aggregate will collect in the filtration bag(s) in the filtration tray.

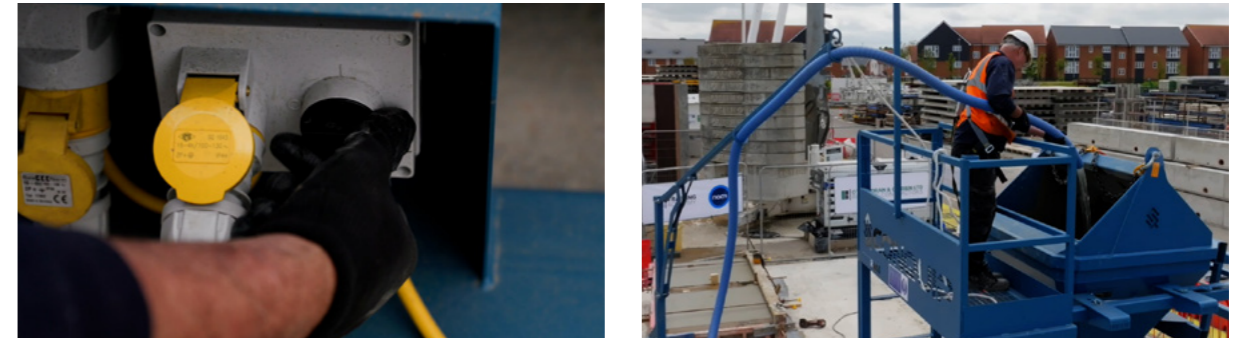

12. The filtration bag will begin to fill up with large aggregate. When full, this bag can be lifted out of the tray and disposed of in line with the site's environmental regulations.



13. In the filtration tray, the water flows through the filtration holes into the second compartment.
14. In the second compartment, the automatic switch on the pump will activate, transferring water from the tray into the water storage tank.
15. Once the water level drops to a sufficient level, the pump automatically turns off, preventing unnecessary wear and tear.
16. After all equipment has been washed, the system must be turned off using the switch on the side of the water storage tank frame. Conquip recommend the operative on ground level controls the water flow.



### CLEANING A CONCRETE TRUCK CHUTE

01. To wash out the chute of a concrete truck, Conquip recommend arranging 4 filtration bags in the filtration tray to capture the maximum amount of concrete aggregate.



02. Slowly reverse the truck positioning the concrete chute over the filtration bags in the filtration tray.

03. The driver can then clean the chute, as per their normal procedure, with the filtration tray collecting any excess concrete waste.



04. Once clean, the driver can raise the chute into its 'transport position' and leave site.

### AFTER USE INSTRUCTIONS

After all equipment has been cleaned, the concrete waste and wastewater needs to be disposed of according to local environmental guidelines.

- 01. Remove the filtration bags and empty the solid concrete aggregate as per the site's environmental guidance.
- 02. The water storage tank can be crane lifted onto a concrete slab and the water used for wet curing.
- 03. Alternatively, pH neutraliser additive can be poured into the water storage tank to treat the wastewater.



- 04. The water storage tank has a capacity of 2000 litres. If full, Conquip advises adding two 25kg containers of pH neutraliser additive to treat it. However, it is important to test the water to ensure it is safe before disposing of it and that the site's local environmental guidelines have been followed. See chart below for details on how much pH neutraliser additive to use.
- 05. If the site has an arrangement with the concrete plant to reuse the wastewater, it can be pumped from the water storage tank into the concrete truck sent back to make the next batch of concrete. Place the delivery hose in position and turn on the switch on the water storage tank frame to start the flow of water. The pump in the tank pumps water at a rate of 225 litres a minute. If left on continuously, the water storage tank will empty until the floatation switch deactivates the pump. This will take approximately 9 minutes.
- 06. Any remaining water in the filtration tray or the water storage tank must be treated before being disposed of in accordance with the site's environmental regulations.

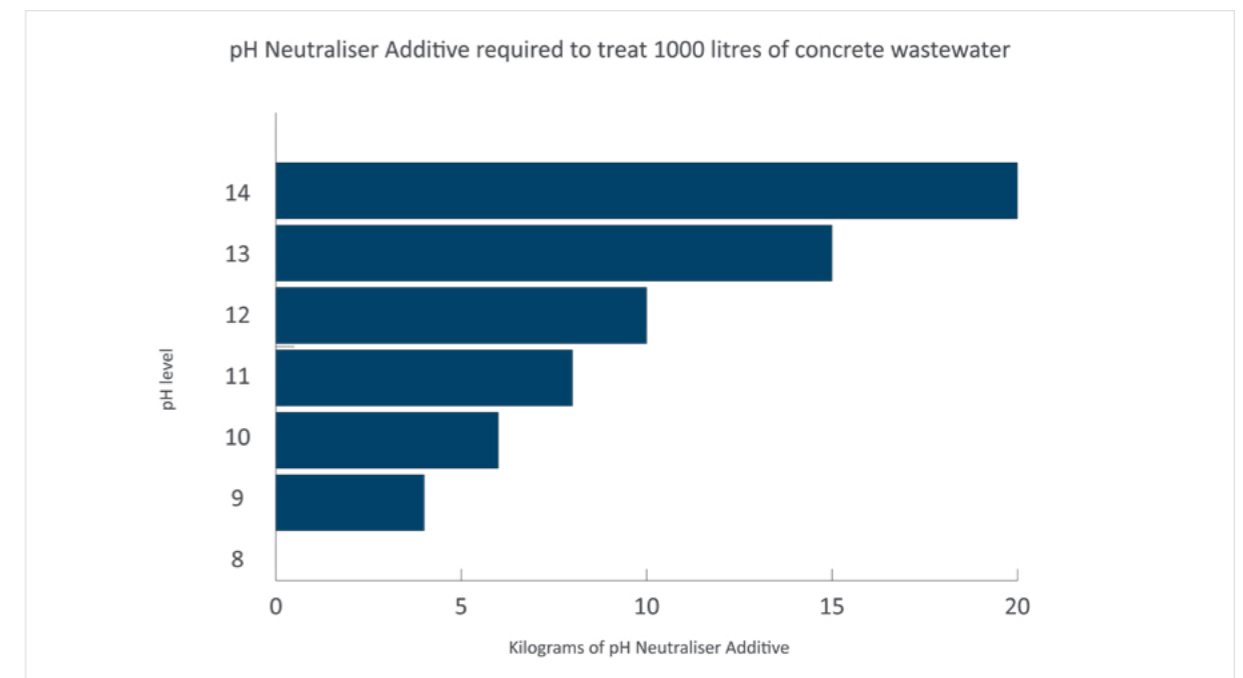

# MAINTENANCE & INSPECTION

## MAINTENANCE REGIME

- It is mandatory that the equipment is thoroughly examined regularly, by a qualified engineer, to ensure compliance with relevant regulations. Conquip recommend carrying out a thorough examination every six months.
- This equipment may incorporate various loose and detachable items including, but not limited to pins, bolt assemblies and adaption plates. Refer to the separate requirements for the safe use of those items.
- When not being used, store the unit in a clean, upright condition and in a safe place where it will be protected from thieves and unauthorised users.
- This equipment must be inspected by the responsible person before each use and then regularly, as determined by your risk assessment or working practice. If you have any concerns about the equipment's condition or suitability, do not use it.

## VISUAL INSPECTION CHECKLIST

### FILTRATION TRAY

INSPECTION ITEMS	RESULTS		COMMENTS
	SATISFACTORY	UNSATISFACTORY	
Serial Number			CQ.....
Product Code			
Working Load Limit (kg)			
Conforms to user guide specification			
Lift points bent or worn			
Bulk bag rails in place			
Pump chamber cover plate in place			
Pump and hose connected			
General visual inspection of the body			
<b>SIGNATURE</b>			
Name	Position	Qualification	Signature & Date

### VISUAL INSPECTION CHECKLIST

#### SKIP WASHING PLATFORM

INSPECTION ITEMS	RESULTS		COMMENTS
	SATISFACTORY	UNSATISFACTORY	
Serial Number			CQ.....
Product Code			
Working Load Limit (kg)			
Conforms to user guide specification			
Harness point secure			
Handrails secure and not damaged			
Gate working			
Lift points bent or worn			
Adjustment brackets in place			
Adjustment cross bar in place			
Linch pins present			
General visual inspection of the body			
SIGNATURE			
Name	Position	Qualification	Signature & Date

### VISUAL INSPECTION CHECKLIST

#### WATER STORAGE TANK

INSPECTION ITEMS	RESULTS		COMMENTS
	SATISFACTORY	UNSATISFACTORY	
Serial Number			CQ.....
Product Code			
Working Load Limit (kg)			
Conforms to user guide specification			
Hose arm assembly in place			
Water hoses damaged			
Electric supply damage			
Lift points bent or worn			
General visual framework inspection			
General visual tank inspection			
Pump operational			
SIGNATURE			
Name	Position	Qualification	Signature & Date

# GENERAL SAFETY INSTRUCTIONS

The equipment should be properly operated and maintained to keep it in a safe, efficient operating condition. Be sure that all fixings and components are free of mud or other matter that might cause issues hazardous to the operator, service personnel and other personnel or equipment. Report all malfunctions to those responsible for maintenance, and do not operate the equipment until corrected. Normal service or maintenance performed as required can prevent unexpected and unnecessary downtime.

This operations manual describes general inspections, servicing and operation with the normal safety precautions required for normal servicing and operating conditions. It is not a guide, however, for abnormal conditions or situations, service personnel and operators must be safety conscious and alert to recognise potential servicing or operating safety hazards at all times, and take necessary precautions to assure safe servicing and operation of the equipment.



**M002**  
Refer to instructions manual



**M004**  
Wear eye protection



**M008**  
Wear safety footwear



**M009**  
Wear protective gloves



**M010**  
Wear protective clothing



**M014**  
Wear head protection



**M015**  
Wear high-visibility clothing



**M015**  
Wear a safety harness

## GENERAL NOTES

- Read this operations manual and learn the operating characteristics and limitations of the equipment. Know what operating clearances the machine requires.
- Read and understand all the safety signs prior to operation.
- If the safety signs are obstructed by dirt or debris, clean them using mild soap and water prior to operation.
- If the safety signs are damaged or illegible, replace them immediately, prior to operation.
- Be aware of operating hazards that weather changes can create on the job. Know proper procedures to follow when a severe rain or electrical storm strikes.
- Never attempt to operate or work on machinery when not feeling physically fit.
- Never wear loose clothing, rings, watches, heavy gloves etc., that might catch and result in injury.
- Know what safety equipment (PPE) is required and use it. Such equipment may be: hard hat, safety glasses, reflector type vests, protective gloves and safety footwear.

## MATERIALS SAFETY DATA SHEET

- Below are the contact details for the manufacturer of the pH neutraliser additive.
- For the full Material Safety Data Sheet (MSDS) please [click here](#).

RELEVANT IDENTIFIED USES OF THE SUBSTANCE OR MIXTURE AND USES ADVISED AGAINST	
Product name	pH Blue
Use of substance / mixture	Construction materials
DETAILS OF THE SUPPLIER OF THE SAFETY DATA SHEET	
Company name	Mudtech Ltd
Address	Wyburn House 1 Crab Lane Stafford Staffordshire ST16 1SB
Tel:	+44 (0) 1929 551 245
Fax:	+44 (0) 1929 554 361
Email:	sales@mudtech.co.uk

# TERMS & CONDITIONS

## CONQUIP ENGINEERING GROUP STANDARD PRODUCT WARRANTY

### 01. COMMENCEMENT

1.1 This Warranty shall commence on the Commencement Date and shall continue until the earlier of:

- (a) the Expiry Date; or
- (b) the date on which it may be voided in accordance with clause 4.1(b)

when it shall terminate automatically without notice.

### 02. DUTY OF GOOD FAITH

2.1 The Purchaser shall in the exercise of its rights under this Warranty and in the compliance with its obligations under this Warranty be subject to and shall in all respects owe and comply with a duty of good faith to the Warrantor.

### 03. NATURE AND EXTENT OF COVER

3.1 Subject to clause 3.2 the Warrantor agrees and undertakes to the Purchaser that it shall be liable to the Purchaser under and in accordance with the terms of this Warranty in the event that:

- (a) prior to the Expiry Date the Purchaser shall notify a Warranty Claim to the Warrantor; and
- (b) the Equipment or any relevant part of the Equipment shall have become unusable as the result of defective material or defective workmanship prior to the Expiry Date.

3.2 The Warrantor's obligation under clause 3.1 shall be expressly subject to the provisions of clauses 4, 5 and 6 and conditional upon the Purchaser's compliance in full with the provisions of clause 7.

### 04. RESTRICTIONS

4.1 The following restrictions apply to this Warranty:

(a) This Warranty is personal to the Purchaser and neither the legal benefit nor legal burden of this warranty may be assigned or novated or otherwise transferred by the Purchaser to any other party. Any purported assignment, novation or transfer shall not be binding upon the Warrantor.

(b) This Warranty shall be void in the event that the Purchaser:

(i) cannot provide authentic and original documentary evidence that the Purchaser has during the period between the Commencement Date and the Expiry Date complied with the Maintenance and Servicing Requirements; and/or

(ii) has, during the period between the Commencement Date and the Expiry Date, exceeded the Purchaser's Usage Cycle Parameters; and/or

(iii) has, during the period between the Commencement Date and the Expiry Date, exceeded the Purchaser's Use Parameters; and/or

(iv) has carried out, or procured the carrying out by any third party of, any repair to the Equipment or any part of the Equipment which is not an Authorised Repair; and/or

(v) has operated the Equipment after having replaced any part of the Equipment with a part which has not been supplied and fitted by the Warrantor; and/or

(vi) has modified the Equipment in any way prior to use.

### 05. EXCLUSIONS

5.1 The following are excluded from the scope of this Warranty:

(a) Loss of and/ or damage to the Equipment or any part of it resulting from any collision between the Equipment and any other fixed or stationary or mobile object whatsoever, irrespective of whether that collision was or was not caused by the Purchaser; and/or

(b) Loss of and/or damage to any personal property and/or possessions or other equipment not forming part of the Equipment but which is present in or about the Equipment; and/or

(c) loss and/or damage which is covered by any other insurance policy taken out and maintained by the Purchaser or in respect of which the Purchaser has a contractual obligation to do so; and/or

(d) loss and/or damage to the equipment which is consistent with the use by the Purchaser of the Equipment:

(i) in compliance with the Maintenance and Servicing Requirements; and

(ii) in compliance with the Usage Cycle Parameters; and

(iii) in compliance with the Use Parameters; and

(iv) having only carried out Authorised Repairs to the Equipment; and

(v) having all and any replacement parts fitted by the Warrantor; and

(vi) in unmodified form.

## 06. LIMITATION OF LIABILITY

6.1 The Warrantor's liability to the Purchaser shall be limited as follows:

- (a) The Warrantor shall not in any circumstances be liable to the Purchaser for indirect and/or consequential and/or economic loss suffered and/or incurred as the case may be by the Purchaser; and
- (b) The Warrantor shall only be liable to the Purchaser for the reasonable and proper costs reasonably and properly incurred by the Purchaser directly in connection with the repair and/or replacement (at the Warrantor's absolute discretion) of the Equipment or any part of the Equipment; and
- (c) The Warrantor's liability to the Purchaser shall notwithstanding any other provision of this Warranty, not in any circumstances exceed the Purchase Price of the Equipment.

## 07. WARRANTY CLAIMS

7.1 The Purchaser shall in respect of any claim against the Warrantor under this Warranty and within 24 hours of the occurrence of the subject matter of the Warranty Claim:

- (a) Complete in full and submit to the Warrantor a Warranty Claim in the form annexed to Schedule 4;
- (b) Provide date stamped or date identifiable photographs evidencing the claim; and
- (c) Make the Equipment or the relevant part of the Equipment available to the Warrantor for inspection within 48 hours of notification of the relevant Warranty Claim.

## 08. ENTIRE AGREEMENT

8.1 This Warranty constitutes the entire agreement between the parties and supersedes and extinguishes all previous promises, assurances, warranties, representations and understandings between them, whether written or oral, relating to its subject matter.

8.2 Each party agrees that it shall have no remedies in respect of any statement, representation, assurance or warranty (whether made innocently or negligently) that is not set out in this Warranty. Each party agrees that it shall have no claim for innocent or negligent misrepresentation or negligent misstatement based on any statement in this Warranty.

No variation of this Warranty shall be effective unless it is in writing and signed by the parties (or their authorised representatives).

## 09. WAIVER

No failure or delay by a party to exercise any right or remedy provided under this Warranty or by law shall constitute a waiver of that or any other right or remedy, nor shall it prevent or restrict the further exercise of that or any other right or remedy. No single or partial exercise of such right or remedy shall prevent or restrict the further exercise of that or any other right or remedy.

## 10. SEVERANCE

10.1 If any provision or part-provision of this Warranty is or becomes invalid, illegal or unenforceable, it shall be deemed deleted, but that shall not affect the validity and enforceability of the rest of this Warranty.

10.2 If any provision or part-provision of this Warranty is deemed deleted under clause 10.1 the parties shall negotiate in good faith to agree a replacement provision that, to the greatest extent possible, achieves the intended commercial result of the original provision.

## 11. THIRD PARTY RIGHTS

11.1 This Warranty does not give rise to any rights under the Contracts (Rights of Third Parties) Act 1999 to enforce any term of this Warranty.

## 12. GOVERNING LAW

12.1 This Warranty and any dispute or claim (including non-contractual disputes or claims) arising out of or in connection with it or its subject matter or formation shall be governed by and construed in accordance with the law of England and Wales.

## 13. JURISDICTION

13.1 Each party irrevocably agrees that the courts of England and Wales shall have exclusive jurisdiction to settle any dispute or claim (including non-contractual disputes or claims) arising out of or in connection with this Warranty or its subject matter or formation.

# DESIGN CONFORMITY (EC & UK)

(01) This certificate meets the requirements of the Machinery Directive 2023/42/EC of the European Parliament and Council.

(02) This certificate meets the requirements of the Supply of Machinery (Safety) Regulations 2008.

## DETAILS

### NAME & ADDRESS OF MANUFACTURER:

Conquip Engineering Group Ltd, Unit 4, Waterbrook Estate, Alton, Hampshire. GU34 2UD

### NAME & ADDRESS OF PERSON TO COMPILE TECHNICAL FILE:

Name: Milad Farhangnia

Address: Conquip Engineering Group, Unit 4, Waterbrook Estate, Alton, Hampshire. GU34 2UD

### NAME & ADDRESS OF AUTHORISED REPRESENTATIVE IF ONE HAS BEEN MANDATED BY THE MANUFACTURER:

N/A

### NAME, ADDRESS, AND IDENTIFICATION NUMBER OF THE NOTIFIED BODY (01) OR APPROVED BODY (02), WHERE APPLICABLE:

N/A

## EQUIPMENT DESCRIPTION

PRODUCT CODES	GENERAL DESCRIPTION / DESIGNATION	WORKING LOAD LIMIT
CA236AE-01800	Filtration Tray	1000kg
CS241	Skip Washing Platform	Self Weight
FB306-02000	Water Storage Tank	2000kg

## HARMONISED STANDARDS & REGULATIONS

ITEM	CODE	DESCRIPTION
EC DIRECTIVE/ REGULATION	2023/42/EC	Directive 2023/42/EC- new machinery directive
HARMONISED STANDARDS	BS EN ISO 12100:2010	Safety of machinery General principles for design Risk assessment and risk reduction
	BS EN 13155:2020	Crane Safety. Non-fixed load lifting attachments
OTHER REGULATIONS	LOLER 1998	Lifting Operations and Lifting Equipment Regulations 1998 (LOLER)
	PUWER 1998	Provision and Use of Work Equipment Regulations 1998 (PUWER)

## DECLARATION

### PLACE OF DECLARATION:

Alton

### DATE OF DECLARATION:

November 2025

I declare that the above equipment meets the Essential Health and Safety requirements of the

(01) Machinery Directive 2023/42/EC of the European Parliament and of the Council

(02) Supply of Machinery (Safety) Regulations 2008 and Section 6 of the Health and Safety at Work Etc. Act 1974.

NAME:	POSITION:	SIGNATURE:
Daniel Critchley	Managing Director	

TALKING TO US IS EASY  
**WE'RE HERE TO HELP**

Call us on 0333 300 3470  
Email us at [sales@cqegroup.com](mailto:sales@cqegroup.com)  
[www.cqegroup.com](http://www.cqegroup.com)

