

USER GUIDE

COMPACT CONCRETE WASHOUT UNIT

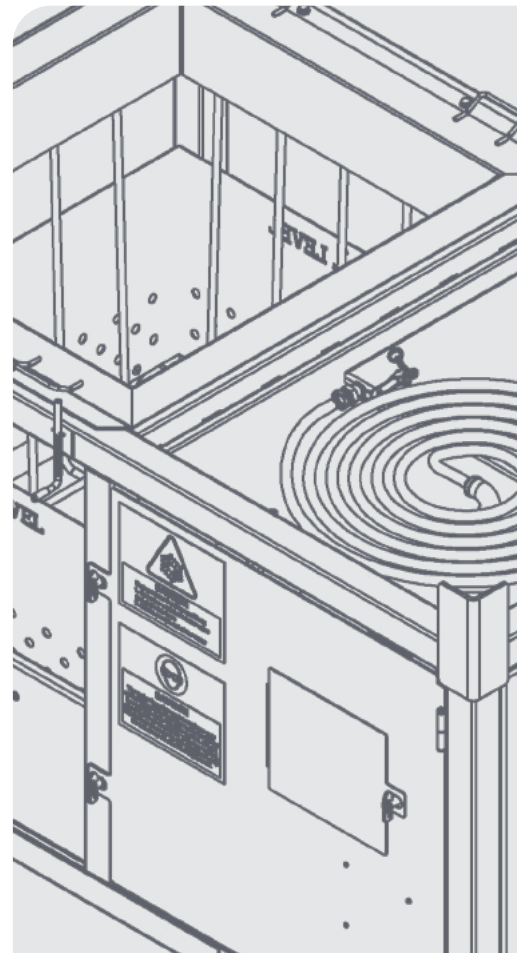

DISCLAIMER

Do not attempt to handle or operate this equipment before you have received sufficient training. Before use, operatives must have carried out all checks featured on the Visual Inspection Sheet on page 13. It is imperative that you have read the General Safety Instructions on page 14 and sufficiently familiarised yourself with the Operational Procedures in this document.

Note that this item is compliant only to the standards specified in this User Guide and it is therefore the duty of the responsible person(s) to review and ensure compliance.

CONTENTS

PRODUCT INFORMATION

INTRODUCTION	04
SPECIFICATION	05
PARTS DIAGRAM	06

OPERATIONAL PROCEDURES

IMPORTANT USAGE NOTES	08
ASSEMBLY INSTRUCTIONS	08
USAGE INSTRUCTIONS	09
LIFTING WITH A FORKLIFT	10
LIFTING WITH A CRANE	11

MAINTENANCE & INSPECTION

MAINTENANCE REGIME	12
SAFETY DECALS	12
VISUAL INSPECTION SHEET	13

GENERAL SAFETY INSTRUCTIONS

SAFETY INSTRUCTIONS	14
GENERAL NOTES	15

LEGAL

TERMS AND CONDITIONS	16
EC DESIGN CONFORMITY	20
STANDARDS AND REGULATIONS APPLICABLE	21

INTRODUCTION

OVERVIEW

Conquip's [Compact Concrete Washout Unit](#) is a concrete waste processing system that recycles, treats and reuses concrete wastewater.

It is primarily used to clean concrete truck chutes but it can also be used to clean smaller concrete equipment. As the concrete equipment is washed, a filtration bag captures large aggregate and the remaining wastewater is pumped into the water tank where it is treated with pH neutraliser additive. The wastewater can then be stored and reused, or safely disposed of, without polluting the environment.

This system is simple to set up, easy to use, and eliminates the need to send concrete waste offsite to be treated.

KEY BENEFITS

- A complete concrete waste processing system where the water is recycled, treated and retained for reuse.
- Quick and easy to set up and use.
- Wash down equipment from multiple sides of the unit, ideal for where space is restricted.
- Prevents contaminated water from concrete washout from polluting the local environment.
- Concrete wastewater is easily treated with pH neutraliser additive dispensed through the water tank's access hatch. See General Safety Instructions on page 15 for details of the Material Safety Data Sheet (MSDS) for the pH neutraliser additive.
- The pH balance of the water in the tank can be monitored using the pH level test kits supplied with the unit and corrected with pH neutraliser additive.
- System runs off a 32Amp power supply and features an additional 110V 16Amp power outlet.
- Two submersible pumps for waste return and washing equipment.
- Pressurised wash hose for efficient concrete removal.
- Fork pockets and designated lifting points for easy manoeuvre around site when empty.

SPECIFICATION

ITEM	PRODUCT CODE
Compact Concrete Washout Unit	CS260AA

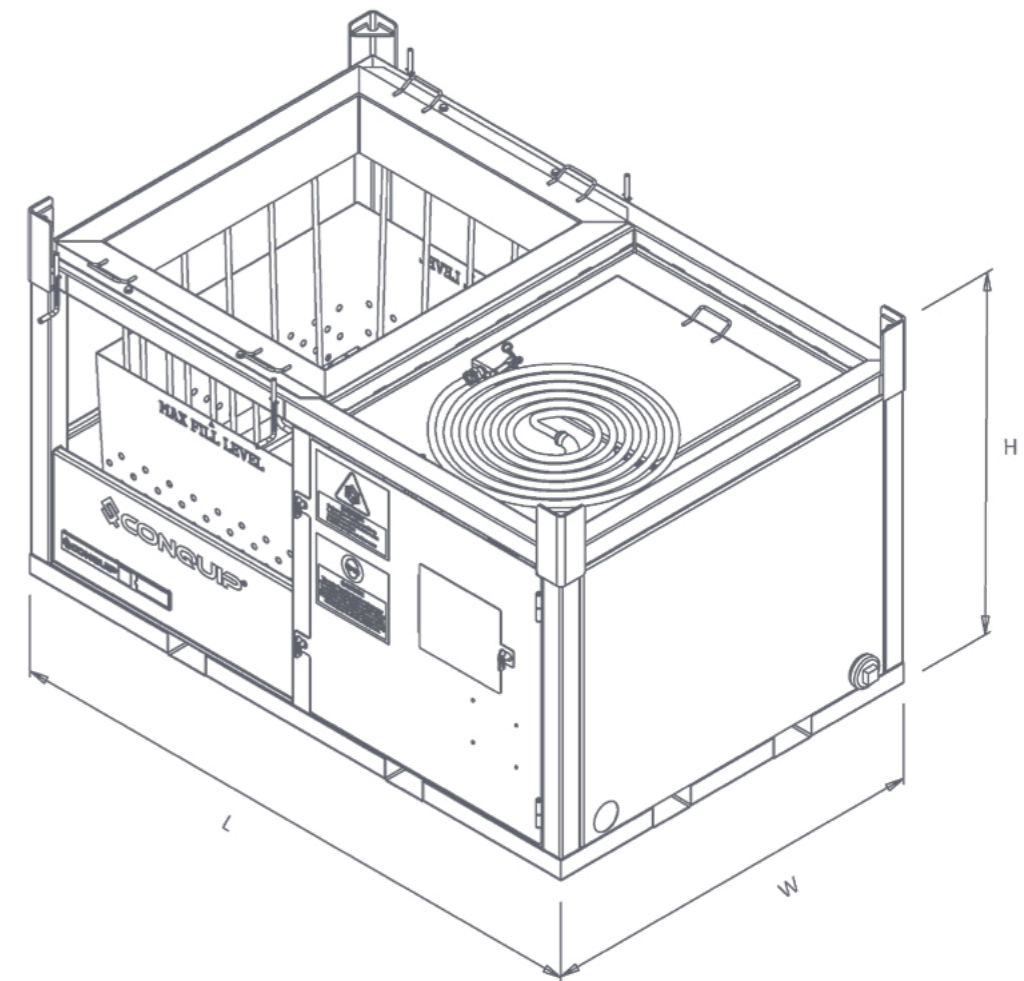

LENGTH (mm)	WIDTH (mm)	HEIGHT (mm)	WEIGHT (kg)	WLL* (kg)	CAPACITY (litres)
2200	1420	1310	675	Self Weight	800

*Working Load Limit

PARTS DIAGRAM

COMPACT CONCRETE WASHOUT UNIT

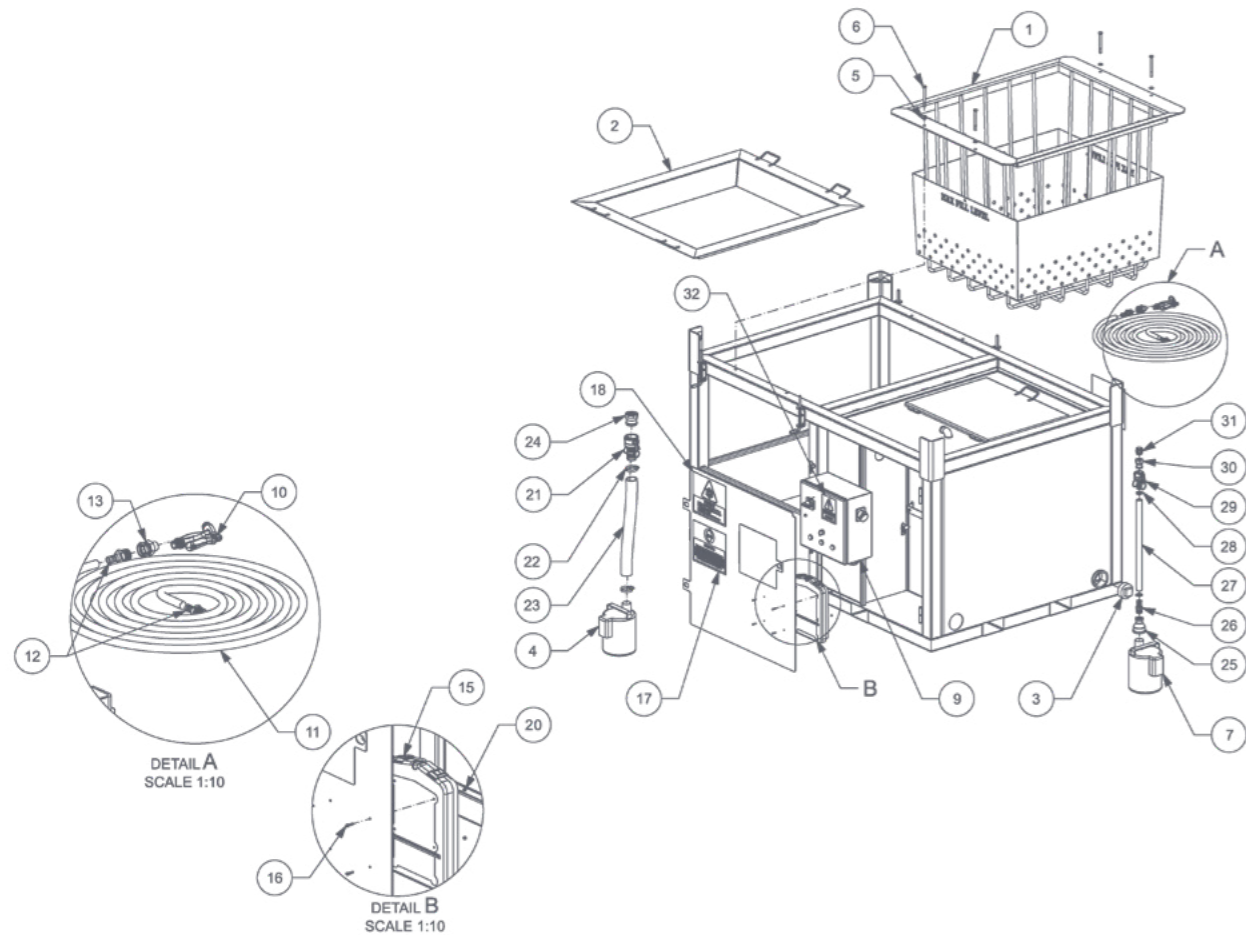

ITEM NO.	PART	DESCRIPTION	QUANTITY
1	N/A	Bag Holding Basket	1
2	N/A	Bag Holding Tray	1
3	ZZ991247	3" Male Plug	2
4	ZZ991260	Submersible Drainage Pump 2" Hosetail Outlet	1
5	NS800454	Plain Washer M12 G8 BZP ISO 7089	4
6	NS800481	Hex Head Bolt M12x1.75 X 120 LG G8.8 BZP ISO 4014	4
7	ZZ991261	Tsurumi LB-480 Angled Outlet 2" BSP Male	1
8	ZZ990464	Decal Refer To Instruction Manual/Booklet	1
9	ZZ991392	Electrical Enclosure 500x400x200	1
10	ZZ991257	Water Spray Gun- 6 Bar	1

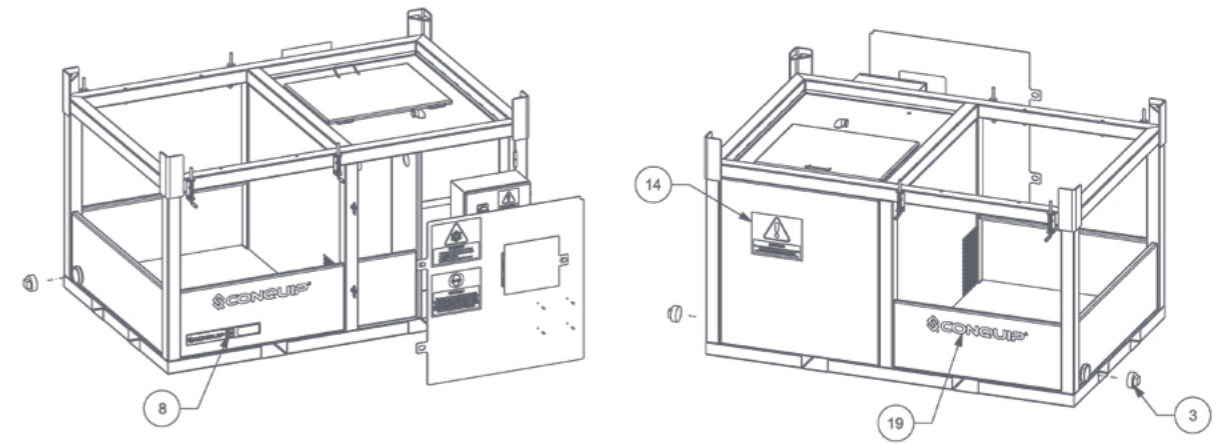

ITEM NUMBER	PART	DESCRIPTION	QUANTITY
11	ZZ991256	3/4" Hose- 8000LG	1
12	ZZ991244	1" BSP Male X 3/4" Hose Tail	2
13	ZZ991396	Hose Swivel 3/4" M BSP To 1" F BSP	1
14	ZZ991371	High Ph Burns Warning Decal 300x250	1
15	ZZ990462	Test Certificate Caddy Box	1
16	NS801160	Hex Head Screw M5x0.8 X 20 LG G8.8 BZP	4
17	ZZ991375	Flying Debris Mandatory Decal 300x250	1
18	ZZ991370	Freeze Warning Decal 300x250	1
19	ZZ991092	Conquip White Decal 600x100mm	2
20	NS800876	Nyloc Nut M5x0.8 G8 BZP	4
21	ZZ990471	2" Kamlock Coupling (Female/Hosetail)	1
22	ZZ990459	Hose Clamp For 2" Hose(64-67mm)	2
23	ZZ991395	2" Hose- Sump To Tank- 650LG	1
24	ZZ990470	2" Kamlock Coupling (Male/Female Bsp)	1
25	ZZ991394	2" To 1" Reducing Socket Female	1
26	ZZ991350	1" Brass Male BSPT X 25mm Hose Tail	1
27	ZZ991349	1" Hose- Motor To Hose Reel- 600LG	1
28	ZZ991354	Hose Clamp For 1" Hose (32-35mm)	2
29	ZZ991361	1" Kamlock Coupling (Female/Hosetail)	1
30	ZZ991243	1" Kamlock Coupling (Male/Female Bsp)	1
31	ZZ991352	1" Hex Nipple Male	1
32	ZZ991374	High Voltage Decal 125x150	1

OPERATIONAL PROCEDURES

IMPORTANT USAGE NOTES

- Check the electric supply is on and sending power to the unit.
- Check the pH balance of the water daily and add pH neutraliser additive, if required.
- Do not attempt to wash concrete skips using this system. Conquip offer a range of alternative solutions for this.
- Ensure the filtration bag is correctly fitted and secure. Do not overfill the filtration bag as it could be difficult to remove after use.
- Only lift the Compact Concrete Washout Unit when it is empty.
- In freezing conditions, ensure the hose has been drained back into the tank and lift both submersible pumps out of the water.
- Ensure you clean any concrete truck chutes or equipment as soon as possible to prevent any concrete drying and becoming difficult to remove.
- Concrete wastewater can cause skin burns; always ensure operatives are wearing the correct PPE when working with concrete.

ASSEMBLY INSTRUCTIONS

01. Place the unit on level ground close to the washout area.
02. Fill the main tank with water through the access hatch and pour one 25kg container of pH neutraliser additive into it. Do not exceed the maximum fill level as indicated by the signage, approximately 800 litres. Check the tank for leaks and seal if required.
03. Fit a filtration bag into the framework. With two operatives, remove the deflector using the designated handles and place to one side. Extend the shoot bolts and wrap the handles of the filtration bag around the shoot bolts. Replace the deflector to secure the bag in place.
04. Plug the 110V 32Amp lead into the supply socket on the control board inside the door. Then plug the other end into the mains supply or a suitable generator.
05. Turn on the red mains switch on the control panel. The two outer green lights should illuminate, indicating there is power at the two sockets.
06. Turn the small black wash pump switch on. The centre green light should illuminate, indicating there is power to the wash pump.
07. Point the hose into the wash area and squeeze the trigger on the wash hose to ensure the water is flowing. There may be some build up of air in the hose; squeeze the trigger until water comes out of the end.
08. The unit is now operational. Turn the electric supply to the unit off until it is required.

USAGE INSTRUCTIONS

01. Turn on the red mains switch to power the system. Turn the small black switch on the control panel to activate the wash pump.
02. Point the hose into the wash area and squeeze the trigger on the wash hose to ensure water is flowing through the system.
03. Reverse the concrete truck towards the unit and position the chute above the filtration bag over the washout area.
04. Use the hose to wash the concrete off the chute, ensuring the waste flows into the filtration bag.
05. The larger aggregate will be captured in the filtration bag and the water will drain into the sump where it will be pumped back into the main water tank.
06. When washing is complete, turn off the small black switch to prevent damage to the wash pump. Conquip advises not to leave the wash pump on for long periods when the unit is not in use.
07. Check the pH balance of the water in the main tank using the pH test kits provided.
08. Add the correct amount of pH neutraliser additive to the water so it is safe for storage or disposal. Use the graph below to determine how much pH neutraliser additive is required to treat the water. For a full water tank (800 litres), Conquip advises using one 25kg container of pH neutraliser initially, then test the pH level and add more neutraliser as required. Always check with your local environmental regulations for the correct pH level.
09. When washout is complete, turn the red mains switch off to power down the system.

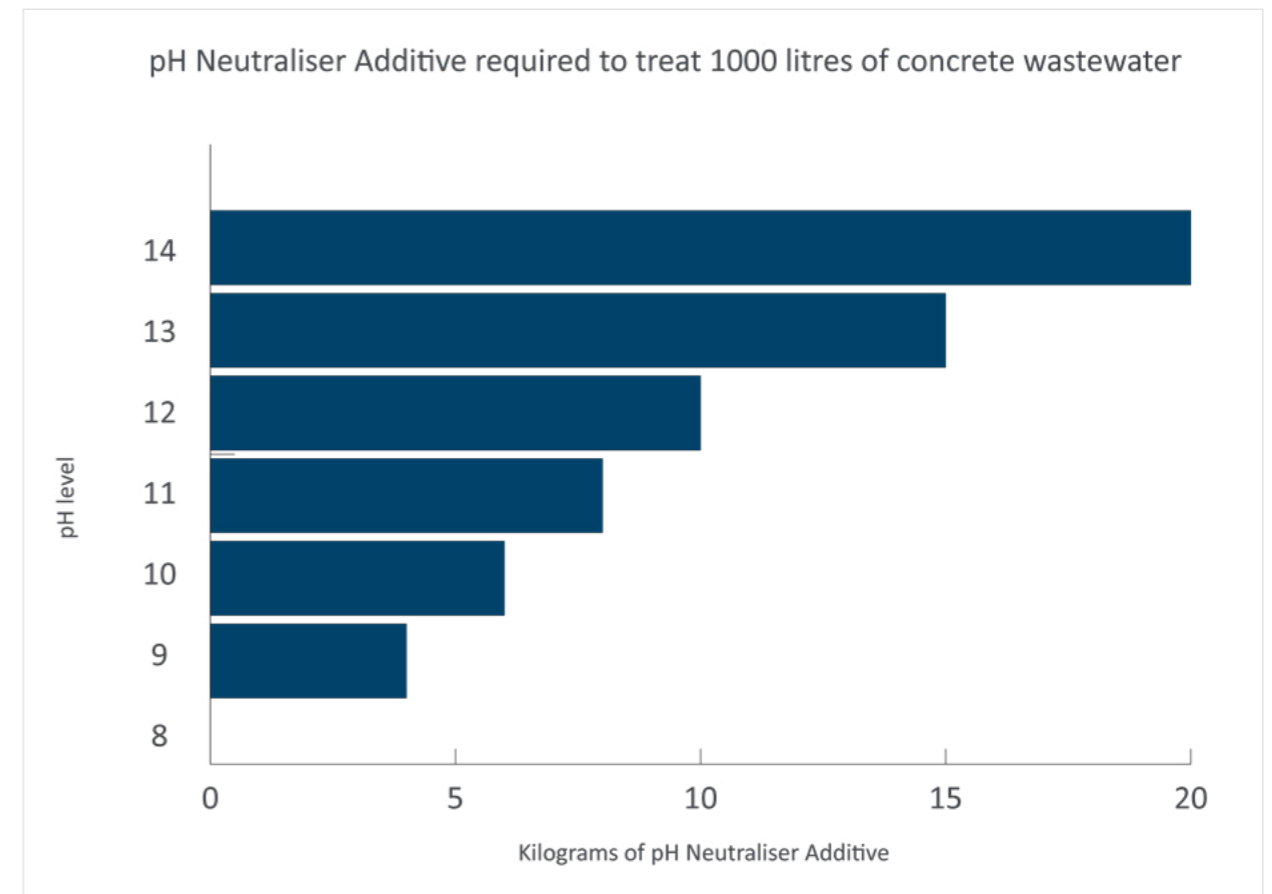

AFTER OPERATIONAL USE

01. After operational use, check the level of solid aggregate in the filtration bag. If it has reached the maximum fill level indicated on the framework, lift the deflector off and place to one side. Retract the shoot bolts, then remove the filtration bag and dispose of it in line with the site's environmental regulations.
02. Fit a new filtration bag by repeating step 03 in the Assembly Instructions on page 08.
03. The Compact Concrete Washout Unit must be completely drained and thoroughly cleaned before being transported or stored to prevent residue build-up and ensure optimal performance upon reuse.
04. Under no circumstances should the unit be transported or lifted while still containing materials or while connected to the mains electricity supply.
05. Ensure that all parts of the system are disassembled, inspected and cleaned in accordance with the Conquip's guidelines before storing the unit for future use.

LIFTING WITH A FORKLIFT

01. Before lifting, ensure the water tank is empty and the bag has been removed from the framework.
02. Unplug the Compact Concrete Washout Unit from the mains power supply.
03. To lift the Compact Concrete Washout Unit with a forklift, set the machine's forks to the correct width for the Compact Concrete Washout Unit's fork pockets. Make sure that they are equidistant from the centre.
04. Drive the forklift to the Compact Concrete Washout Unit, aligning the forks with the fork pockets.
05. Move the forklift forward until the forks are fully inserted into the fork pockets. The Compact Concrete Washout Unit is now ready to lift.
06. Carefully raise the unit just off the ground and check for balance and security.
07. Carefully transport the unit to its required destination, taking care not to jolt.
08. When in position, the Compact Concrete Washout Unit can be lowered onto firm, level ground.
09. Reverse the forklift back and clear of the unit.

LIFTING WITH A CRANE

01. Before lifting, ensure the water tank is empty and the bag has been removed from the framework.
02. Unplug the Compact Concrete Washout Unit from the mains power supply.
03. Attach a suitable four-leg chain sling to the two Compact Concrete Washout Unit's lifting points.
04. Carefully raise the unit just off the ground and check for balance and security.
05. Carefully transport the unit to its required destination, taking care not to jolt.
06. When in position, the unit can be lowered onto firm, level ground.
07. Detach the Compact Concrete Washout Unit from the lifting chains.

MAINTENANCE & INSPECTION

MAINTENANCE REGIME

- It is mandatory that the equipment is thoroughly examined regularly, by a qualified engineer, to ensure compliance with relevant regulations. Conquip recommend carrying out a thorough examination every six months.
- This equipment may incorporate various loose and detachable items including, but not limited to pins, bolt assemblies and adaption plates. Refer to the separate requirements for the safe use of those items.
- When not being used, store the unit in a clean, upright condition and in a safe place where it will be protected from thieves and unauthorised users.
- This equipment must be inspected by the responsible person before each use and then regularly, as determined by your risk assessment or working practice. If you have any concerns about the machinery's condition or suitability, do not use it.

SAFETY DECALS

These are the safety decals featured on the equipment. When carrying out the visual inspection of the equipment, please ensure all decals are present before checking this item off the list.

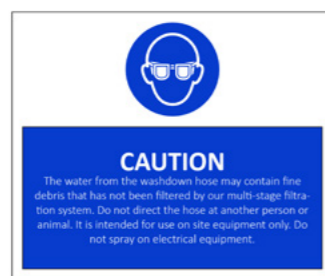

VISUAL INSPECTION CHECKLIST

INSPECTION ITEMS	RESULTS		COMMENTS
	SATISFACTORY	UNSATISFACTORY	
Serial Number			CQ.....
Product Code			
Working Load Limit (kg)			
Conforms to user guide specification			
Check the pH level of water in the water tank			
Check water tank for damage or leaks			
Check pump gauze is clear of debris			
Check hose for damage or leaks			
Check hose trigger operation			
Check lifting points for wear or damage			
Check fill level of bag and replace if required			
Check operation of electrical system			
Check safety decals are present and visible			
General visual inspection of the body			
SIGNATURE			
Name	Position	Qualification	Signature & Date

GENERAL SAFETY INSTRUCTIONS

The equipment should be properly operated and maintained to keep it in a safe, efficient operating condition. Be sure that all fixings and components are free of mud or other matter that might cause issues hazardous to the operator, serviceman, or other personnel or equipment. Report all malfunctions to those responsible for maintenance, and do not operate the equipment until corrected. Normal service or maintenance performed as required can prevent unexpected and unnecessary downtime.

This operations manual describes general inspections, servicing and operation with the normal safety precautions required for normal servicing and operating conditions. It is not a guide, however, for abnormal conditions or situations, and therefore, servicemen and operators must be safety conscious and alert to recognise potential servicing or operating safety hazards at all times, and take necessary precautions to assure safe servicing and operation of the equipment.



M002
Refer to instructions manual



M004
Wear eye protection



M008
Wear safety footwear



M009
Wear protective gloves



M010
Wear protective clothing



M014
Wear head protection



M015
Wear high-visibility clothing

GENERAL NOTES

- Read this operations manual and learn the operating characteristics and limitations of the equipment. Know what operating clearances the machine requires.
- Read and understand all the safety signs prior to operation.
- If the safety signs are obstructed by dirt or debris, clean them using mild soap and water prior to operation.
- If the safety signs are damaged or illegible, replace them immediately, prior to operation.
- Be aware of operating hazards that weather changes can create on the job. Know proper procedures to follow when a severe rain or electrical storm strikes.
- Never attempt to operate or work on machinery when not feeling physically fit.
- Never wear loose clothing, rings, watches, heavy gloves etc., that might catch and result in injury.
- Know what safety equipment (PPE) is required and use it. Such equipment may be: hard hat, safety glasses, reflector type vests, protective gloves and safety footwear.

MATERIALS SAFETY DATA SHEET

- Below are the contact details for the manufacturer of the pH neutraliser additive.
- For the full Material Safety Data Sheet (MSDS) please [click here](#).

RELEVANT IDENTIFIED USES OF THE SUBSTANCE OR MIXTURE AND USES ADVISED AGAINST	
Product name	pH Blue
Use of substance / mixture	Construction materials
DETAILS OF THE SUPPLIER OF THE SAFETY DATA SHEET	
Company name	Mudtech Ltd
Address	Wyburn House 1 Crab Lane Stafford Staffordshire ST16 1SB
Tel:	+44 (0) 1929 551 245
Fax:	+44 (0) 1929 554 361
Email:	sales@mudtech.co.uk

TERMS & CONDITIONS

CONQUIP ENGINEERING GROUP STANDARD PRODUCT WARRANTY

01. COMMENCEMENT

1.1 This Warranty shall commence on the Commencement Date and shall continue until the earlier of:

- (a) the Expiry Date; or
- (b) the date on which it may be voided in accordance with clause 4.1(b)

when it shall terminate automatically without notice.

02. DUTY OF GOOD FAITH

2.1 The Purchaser shall in the exercise of its rights under this Warranty and in the compliance with its obligations under this Warranty be subject to and shall in all respects owe and comply with a duty of good faith to the Warrantor.

03. NATURE AND EXTENT OF COVER

3.1 Subject to clause 3.2 the Warrantor agrees and undertakes to the Purchaser that it shall be liable to the Purchaser under and in accordance with the terms of this Warranty in the event that:

- (a) prior to the Expiry Date the Purchaser shall notify a Warranty Claim to the Warrantor; and
- (b) the Equipment or any relevant part of the Equipment shall have become unusable as the result of defective material or defective workmanship prior to the Expiry Date.

3.2 The Warrantor's obligation under clause 3.1 shall be expressly subject to the provisions of clauses 4, 5 and 6 and conditional upon the Purchaser's compliance in full with the provisions of clause 7.

04. RESTRICTIONS

4.1 The following restrictions apply to this Warranty:

(a) This Warranty is personal to the Purchaser and neither the legal benefit nor legal burden of this warranty may be assigned or novated or otherwise transferred by the Purchaser to any other party. Any purported assignment, novation or transfer shall not be binding upon the Warrantor.

(b) This Warranty shall be void in the event that the Purchaser:

(i) cannot provide authentic and original documentary evidence that the Purchaser has during the period between the Commencement Date and the Expiry Date complied with the Maintenance and Servicing Requirements; and/or

(ii) has, during the period between the Commencement Date and the Expiry Date, exceeded the Purchaser's Usage Cycle Parameters; and/or

(iii) has, during the period between the Commencement Date and the Expiry Date, exceeded the Purchaser's Use Parameters; and/or

(iv) has carried out, or procured the carrying out by any third party of, any repair to the Equipment or any part of the Equipment which is not an Authorised Repair; and/or

(v) has operated the Equipment after having replaced any part of the Equipment with a part which has not been supplied and fitted by the Warrantor; and/or

(vi) has modified the Equipment in any way prior to use.

05. EXCLUSIONS

5.1 The following are excluded from the scope of this Warranty:

(a) Loss of and/ or damage to the Equipment or any part of it resulting from any collision between the Equipment and any other fixed or stationary or mobile object whatsoever, irrespective of whether that collision was or was not caused by the Purchaser; and/or

(b) Loss of and/or damage to any personal property and/or possessions or other equipment not forming part of the Equipment but which is present in or about the Equipment; and/or

(c) loss and/or damage which is covered by any other insurance policy taken out and maintained by the Purchaser or in respect of which the Purchaser has a contractual obligation to do so; and/or

(d) loss and/or damage to the equipment which is consistent with the use by the Purchaser of the Equipment:

(i) in compliance with the Maintenance and Servicing Requirements; and

(ii) in compliance with the Usage Cycle Parameters; and

(iii) in compliance with the Use Parameters; and

(iv) having only carried out Authorised Repairs to the Equipment; and

(v) having all and any replacement parts fitted by the Warrantor; and

(vi) in unmodified form.

06. LIMITATION OF LIABILITY

6.1 The Warrantor's liability to the Purchaser shall be limited as follows:

- (a) The Warrantor shall not in any circumstances be liable to the Purchaser for indirect and/or consequential and/or economic loss suffered and/or incurred as the case may be by the Purchaser; and
- (b) The Warrantor shall only be liable to the Purchaser for the reasonable and proper costs reasonably and properly incurred by the Purchaser directly in connection with the repair and/or replacement (at the Warrantor's absolute discretion) of the Equipment or any part of the Equipment; and
- (c) The Warrantor's liability to the Purchaser shall notwithstanding any other provision of this Warranty, not in any circumstances exceed the Purchase Price of the Equipment.

07. WARRANTY CLAIMS

7.1 The Purchaser shall in respect of any claim against the Warrantor under this Warranty and within 24 hours of the occurrence of the subject matter of the Warranty Claim:

- (a) Complete in full and submit to the Warrantor a Warranty Claim in the form annexed to Schedule 4;
- (b) Provide date stamped or date identifiable photographs evidencing the claim; and
- (c) Make the Equipment or the relevant part of the Equipment available to the Warrantor for inspection within 48 hours of notification of the relevant Warranty Claim.

08. ENTIRE AGREEMENT

8.1 This Warranty constitutes the entire agreement between the parties and supersedes and extinguishes all previous promises, assurances, warranties, representations and understandings between them, whether written or oral, relating to its subject matter.

8.2 Each party agrees that it shall have no remedies in respect of any statement, representation, assurance or warranty (whether made innocently or negligently) that is not set out in this Warranty. Each party agrees that it shall have no claim for innocent or negligent misrepresentation or negligent misstatement based on any statement in this Warranty.

No variation of this Warranty shall be effective unless it is in writing and signed by the parties (or their authorised representatives).

09. WAIVER

No failure or delay by a party to exercise any right or remedy provided under this Warranty or by law shall constitute a waiver of that or any other right or remedy, nor shall it prevent or restrict the further exercise of that or any other right or remedy. No single or partial exercise of such right or remedy shall prevent or restrict the further exercise of that or any other right or remedy.

10. SEVERANCE

10.1 If any provision or part-provision of this Warranty is or becomes invalid, illegal or unenforceable, it shall be deemed deleted, but that shall not affect the validity and enforceability of the rest of this Warranty.

10.2 If any provision or part-provision of this Warranty is deemed deleted under clause 10.1 the parties shall negotiate in good faith to agree a replacement provision that, to the greatest extent possible, achieves the intended commercial result of the original provision.

11. THIRD PARTY RIGHTS

11.1 This Warranty does not give rise to any rights under the Contracts (Rights of Third Parties) Act 1999 to enforce any term of this Warranty.

12. GOVERNING LAW

12.1 This Warranty and any dispute or claim (including non-contractual disputes or claims) arising out of or in connection with it or its subject matter or formation shall be governed by and construed in accordance with the law of England and Wales.

13. JURISDICTION

13.1 Each party irrevocably agrees that the courts of England and Wales shall have exclusive jurisdiction to settle any dispute or claim (including non-contractual disputes or claims) arising out of or in connection with this Warranty or its subject matter or formation.

DESIGN CONFORMITY (EC & UK)

- (01) This certificate meets the requirements of the Machinery Directive 2023/42/EC of the European Parliament and Council.
- (02) This certificate meets the requirements of the Supply of Machinery (Safety) Regulations 2008.

DETAILS

NAME & ADDRESS OF MANUFACTURER:
Conquip Engineering Group Ltd, Unit 4, Waterbrook Estate, Alton, Hampshire. GU34 2UD
NAME & ADDRESS OF PERSON TO COMPILE TECHNICAL FILE:
Name: Milad Farhangnia Address: Conquip Engineering Group, Unit 4, Waterbrook Estate, Alton, Hampshire. GU34 2UD
NAME & ADDRESS OF AUTHORISED REPRESENTATIVE IF ONE HAS BEEN MANDATED BY THE MANUFACTURER:
N/A
NAME, ADDRESS, AND IDENTIFICATION NUMBER OF THE NOTIFIED BODY (01) OR APPROVED BODY (02), WHERE APPLICABLE:
N/A

EQUIPMENT DESCRIPTION

PRODUCT CODE(S)	GENERAL DESCRIPTION	WORKING LOAD LIMIT
CS260AA	Compact Concrete Washout Unit	Self Weight

HARMONISED STANDARDS & REGULATIONS

ITEM	CODE	DESCRIPTION
EC DIRECTIVE/REGULATION	2023/42/EC	Directive 2023/42/EC- new machinery directive
HARMONISED STANDARDS	BS EN ISO 12100:2010	Safety of machinery General principles for design Risk assessment and risk reduction
OTHER REGULATIONS	LOLER 1998	Lifting Operations and Lifting Equipment Regulations 1998 (LOLER)
	PUWER 1998	Provision and Use of Work Equipment Regulations 1998 (PUWER)

DECLARATION

PLACE OF DECLARATION:
Alton
DATE OF DECLARATION:
October 2025

I declare that the above equipment meets the Essential Health and Safety requirements of the
 (01) Machinery Directive 2023/42/EC of the European Parliament and of the Council
 (02) Supply of Machinery (Safety) Regulations 2008 and Section 6 of the Health and Safety at Work Etc. Act 1974.

NAME:	POSITION:	SIGNATURE:
Daniel Critchley	Managing Director	

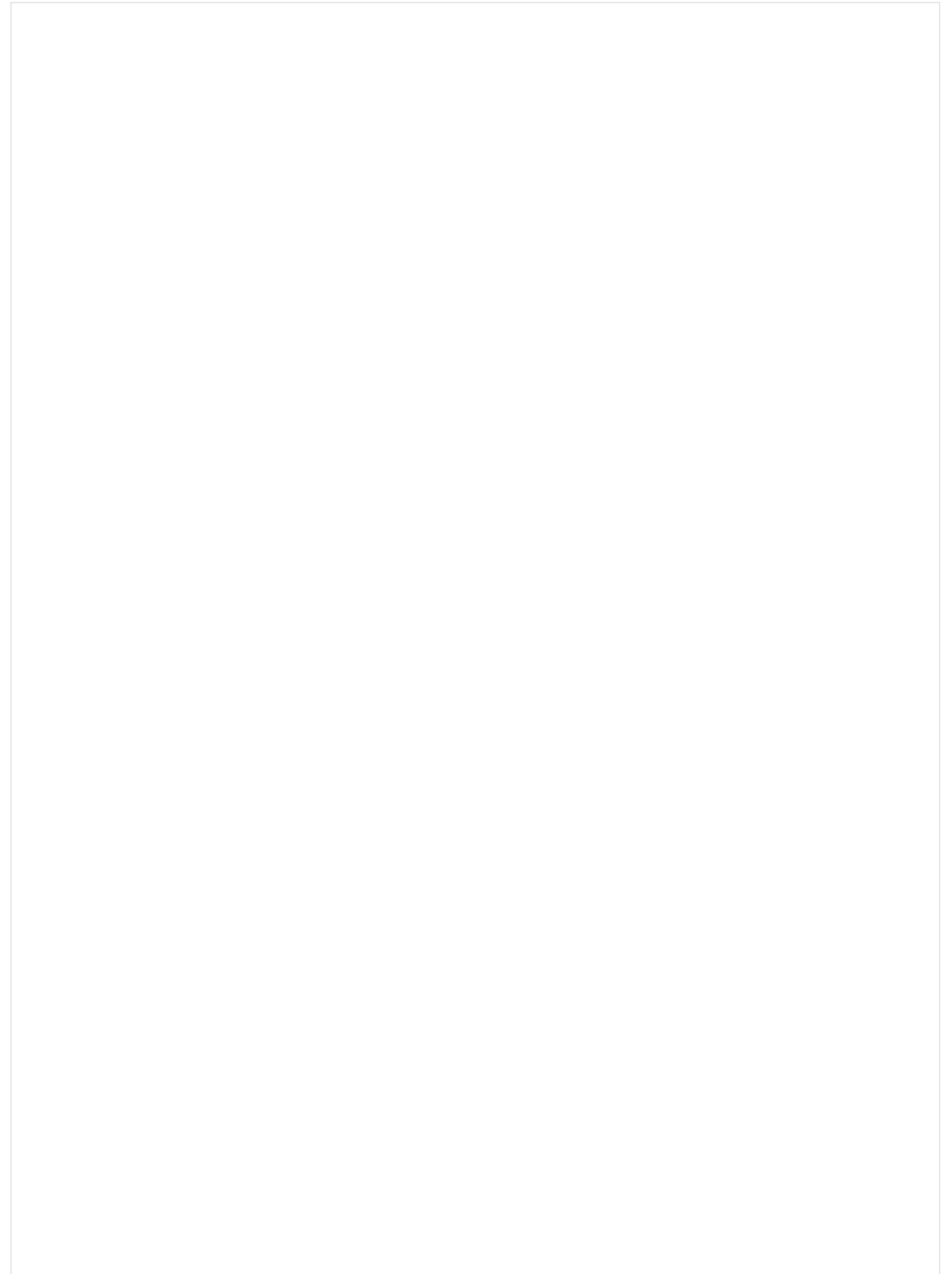
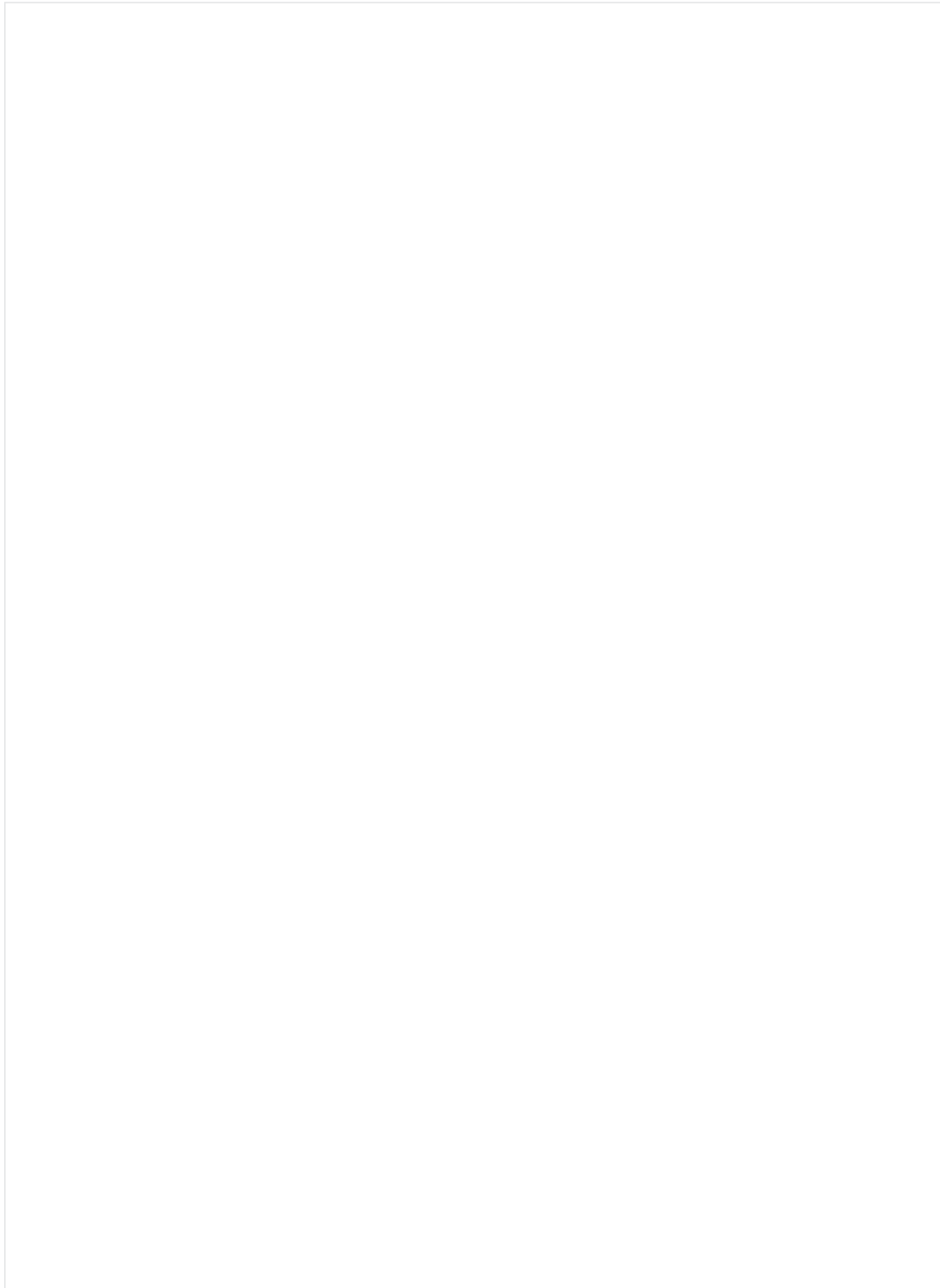

TALKING TO US IS EASY
WE'RE HERE TO HELP

Call us on 0333 300 3470
Email us at sales@cqegroup.com
www.cqegroup.com

