

User Guide

CantiDeck Super Roller



Product Information Specification

Item	Product Code
CantiDeck Super Roller 22	SR22
CantiDeck Super Roller 29	SR29
CantiDeck Super Roller 35	SR35

Product Information Overview

The Conquip CantiDeck is a crane loading platform used for moving equipment and materials efficient in and out of structures during construction.

The [Super Roller CantiDeck](#) can be fully retracted within the frame and building edge so that it is flush with the edge of the structure when not in use. Multiple platforms can be installed in a stacked configuration, meaning there is no downtime relocating platforms between floors, increasing working time and crane efficiency.

Key Benefits

- Fastest loading bay for relocation and installation.
- Large working load capacity and available with multiple configurations to suit most applications.
- Available in a variety of sizes, with bespoke solutions to suit requirements.
- Unique single prop design reduces the weight of the deck and the reaction loadings.
- Quick and simple to install and relocate.
- All installation and relocation training can be provided by our on-site training team.

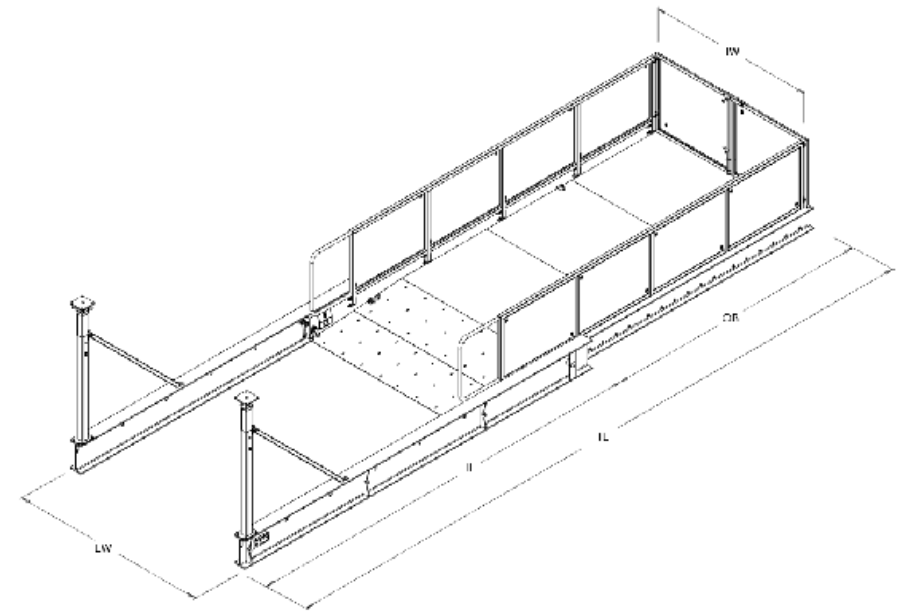

¹Working Load Limit

Product Code	External Width	Internal Width	Outboard Length	Total Length	Weight	WLL ¹
SR22	2200mm	1690mm	3800mm	9600mm	2650kg	5000kg
SR29	2900mm	2390mm	3800mm	9600mm	3000kg	5000kg
SR35	3500mm	2990mm	3800mm	9600mm	3400kg	5000kg

Original Working Instructions

Usage Instructions

Important Usage Notes

- Before starting the install, make sure that any exclusion zones are decided and that all personnel involved are aware. Also ensure that you have a plan in place to restrict access to those areas.
- When installing the platform, some of the team may be required to work at height. Ensure that you have the right equipment to provide access at height and ensure that all hand-held tools are tethered.
- Check that any machinery or lifting equipment you are intending to use has the capability and a sufficient Working Load Limit to carry out the function that you require it to do.
- The doors on the end of the CantiDeck platforms could be a risk for possible unauthorised access or inadvertent opening. A control measure like a bolt or a padlock can be used to secure the doors shut. If you require this particular functionality, a risk assessment must be completed.
- In cases of high winds, please follow your health and safety executive guidelines.
- CantiDeck platforms must not be left unsupervised throughout the loading, unloading and whilst a load is on the deck.

In advance

1. Communicate the date of install with all relevant site teams, according to standard site practice. Decide on exclusion zones and make all involved personnel aware.
2. Consider that some of the team may be required to work at height during the install. Make sure that you have suitable equipment in place to provide access at height and that all hand-held tools are tethered.
3. Check that any machinery or lifting equipment you are intending to use has the capability and a sufficient Working Load Limit to carry out the function that you require it to do.

Install Options

Page 7

Install Option- 1 Rolled Out

Page 17

Install Option- 2 Rolled In

Install Option 1 Rolled Out

On the day

1. Before carrying out an installation, check that the site has the necessary safety precautions in place.

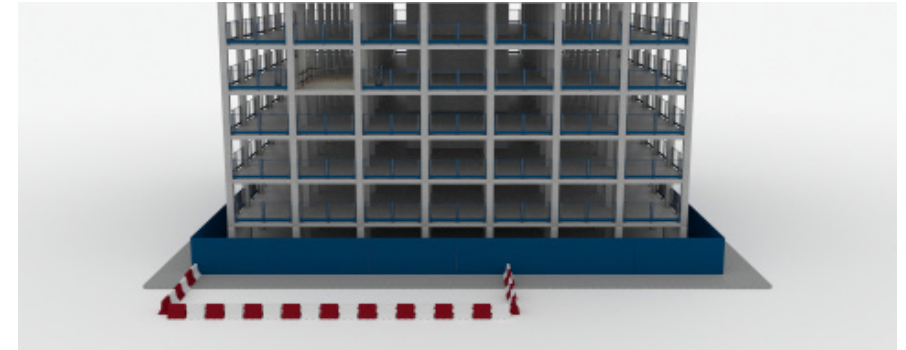

2. Create an exclusion zone at both delivery location and at the location that the platform is being installed.



3. Install location will need a suitable anchor point for leading edge safety equipment to attach.

4. Once the deck has been safely delivered to site, it will need to be removed from the vehicle.
5. The CantiDeck has 4 lifting points. Attach 1 leg of the 4 leg chain to each lifting point.
6. Lift the deck from the vehicle, allow the truck to exit and place the deck flat on the floor.
7. Release the chains and begin to assemble the deck, starting with the side panels.

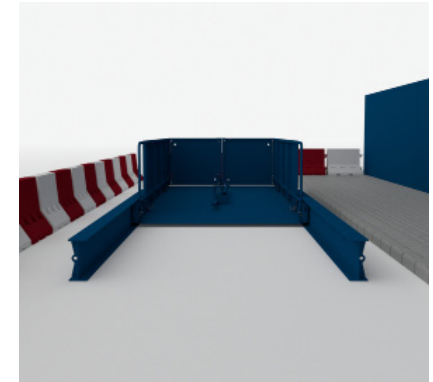
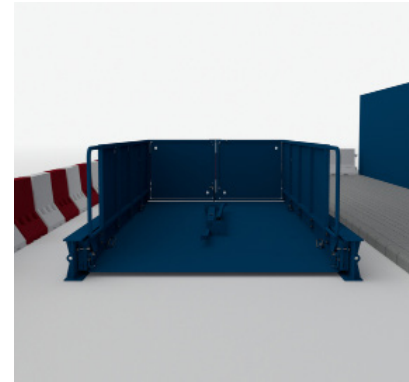

8. Rotate the side panels 90° and secure with bolts.

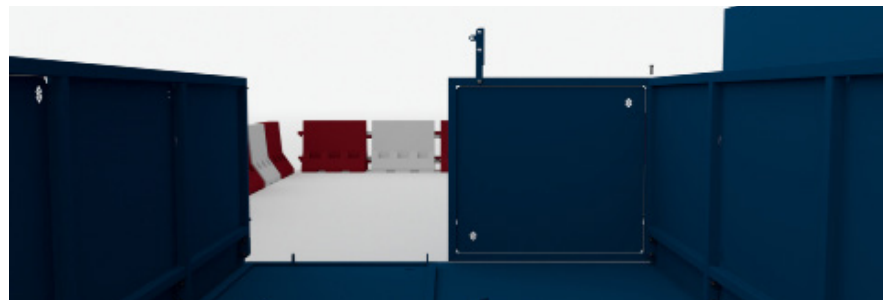

9. Screw Jacks are to be taken up to the install location separately.
10. Lift one door and hang it on its hinges using M16 bolt and Nylon nut connections. Ensure it can pivot on its hinges.
11. Repeat with the other door and then secure with the drop pin and latch.

12. Unlock both shot bolts on either side of the deck and roll out until fully extended.
13. Once fully extended lock into position with the shot bolts on both sides of the rear beams.

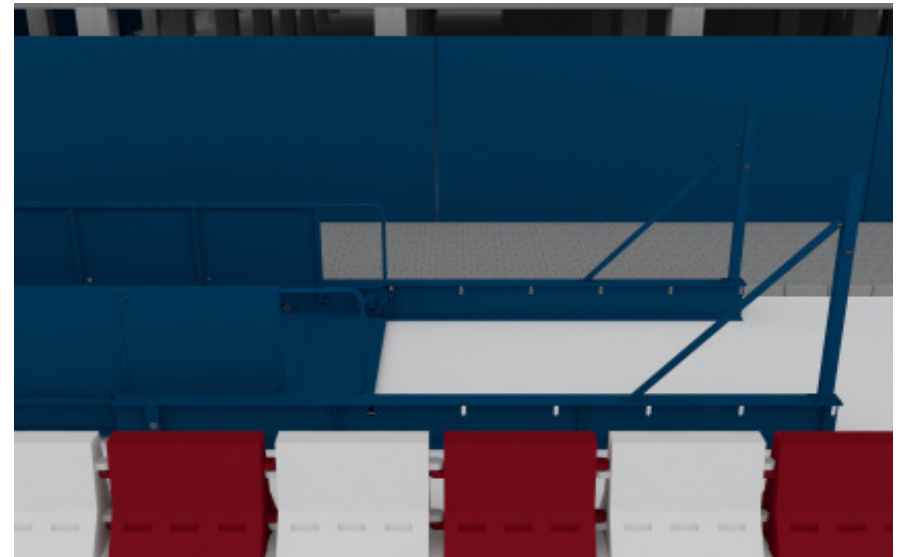

14. Prop and Brace come pre-assembled ready for installation, lift into position and secure with bolts.

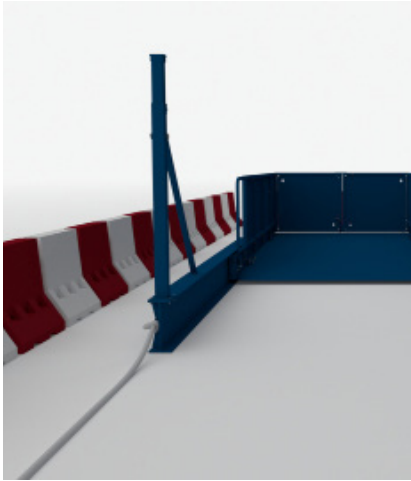

15. Prior to lifting, ensure tag lines are attached to the rear of the deck and in the opposite corner at the front of the deck near the top, so that they can be removed once installed.

18. Ensure load path is clear and guide the deck into position on the edge of the building.

19. Use the tag lines to guide the platform into the building.



16. Attach the 4 leg chain to the lifting points. The use of chain shorteners may be required to adjust the level of the deck.

17. Take the weight with the crane and lift until the platform sits clear of the ground. The deck should be tilted back slightly.

20. Manoeuvre the deck as far back into the building as possible and lower onto the slab so that both beams are flat.



21. Install the Screw Jacks into the Props.
22. Remove the pin from the legs and slide the leg up until the head touches the slab.
23. Then lower the leg until the first hole is visible and re-insert the pin ensuring the safety pin is in place.
24. Wind the screw jack up tight to temporarily prop the deck.

29. Continue to lift the deck until you have a gap high enough to position 2 short scaffold tubes under each beam, securing with a tether.



25. Lower off the crane slowly to enable you to release the 2 chains from the lifting eyes closest to the building.
26. Release the chains and ensure they are clipped out the way so they will not snag on anything.
27. Re-position the crane over the 2 outer lifting points and lift slowly to take the weight of the platform.
28. Release the props and lower by 100mm minimum.

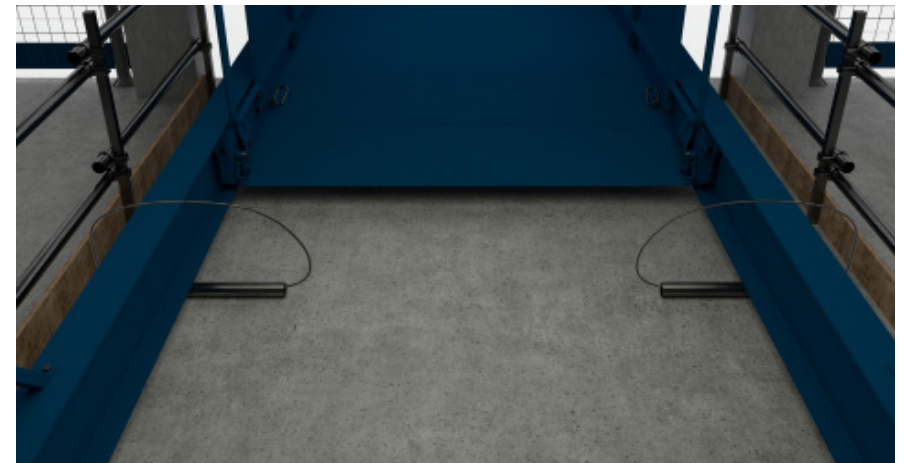

30. Lower the deck slowly, as the weight of the deck sits on the scaffold tubes pull the deck into its final position.
31. Holding the deck still, lift the deck up on the crane to release the scaffold tubes.



32. Lower the deck so that both beams are resting on the floor slab.
33. Remove the pin from the legs and slide the leg up until the head touches the slab.

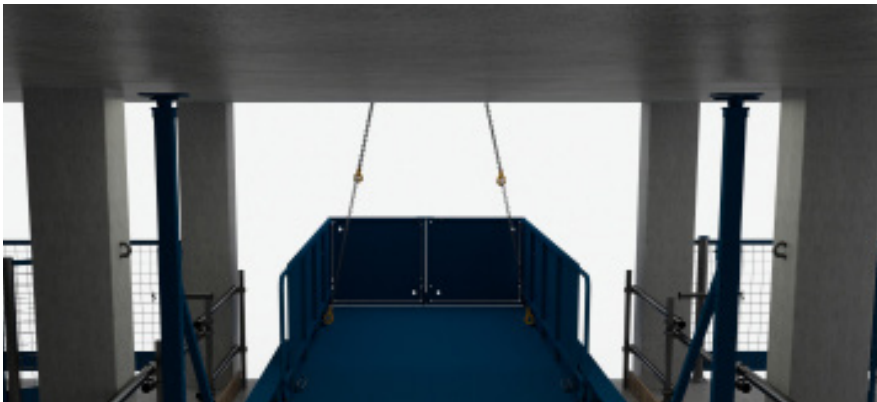

34. Then lower the leg until the first hole is visible and re-insert the pin ensuring the safety pin is in place.
35. Ensure that the base beams are flat and the vertical legs are at 90° to the base beams.

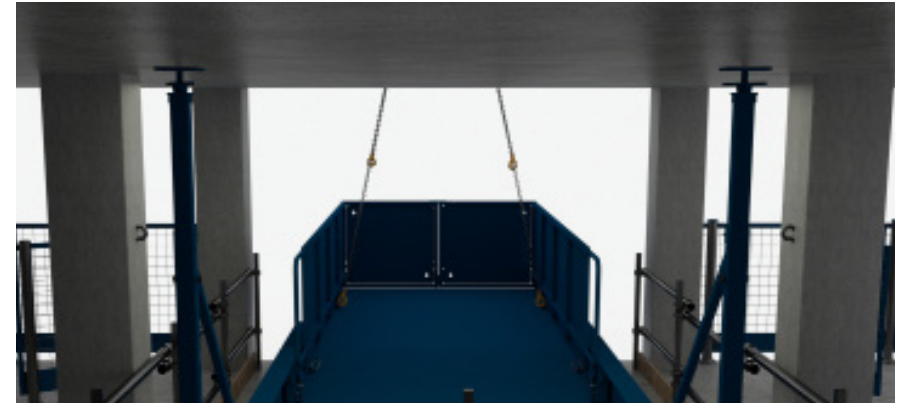

36. Tighten the screw jacks until they are hand tight, then hammer just 1/4 turn extra. There must be no more than 150mm thread showing.
37. Check the screw jacks are tightly secured, slowly lower the crane down and disconnect the lifting chain.



38. Remove the exclusion zone on the slab, ensuring that any gaps at the side of the deck are completed with edge protection.

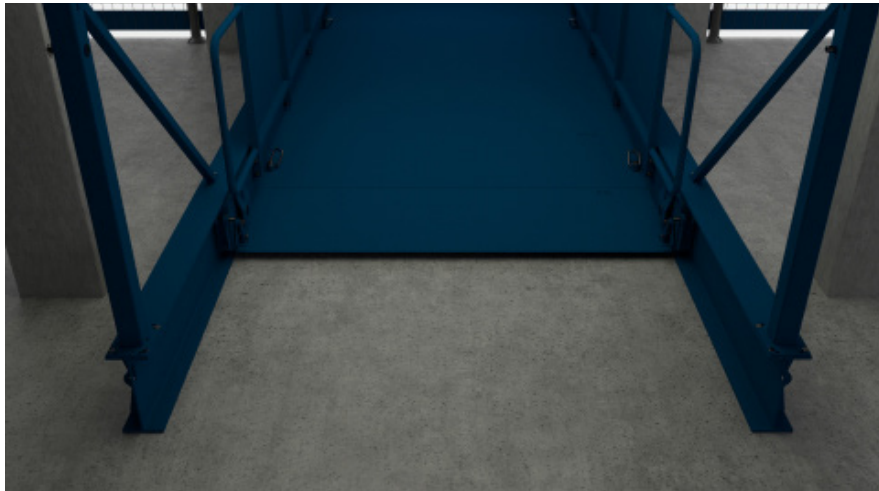

39. Unlock both shot bolts on either side of the deck and roll into the building.
40. Once fully into the building lock into position with the shot bolts on both sides at the rear of the beams.



41. The Super Roller CantiDeck is now successfully installed.

Install Option 2 Rolled In

On the day

1. Before carrying out an installation, check that the site has the necessary safety precautions in place.

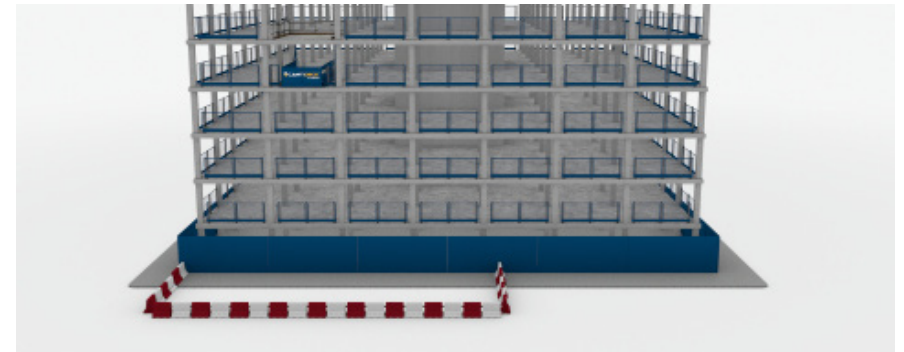

2. Create an exclusion zone at both delivery location and at the location that the platform is being installed.



3. Install location will need a suitable anchor point for leading edge safety equipment to attach.

4. Once the deck has been safely delivered to site, it will need to be removed from the vehicle.
5. The CantiDeck has 4 lifting points. Attach 1 leg of the 4 leg chain to each lifting point.
6. Lift the deck from the vehicle, allow the truck to exit and place the deck flat on the floor.
7. Release the chains and begin to assemble the deck, starting with the side panels.



8. Rotate the side panels 90° and secure with bolts.

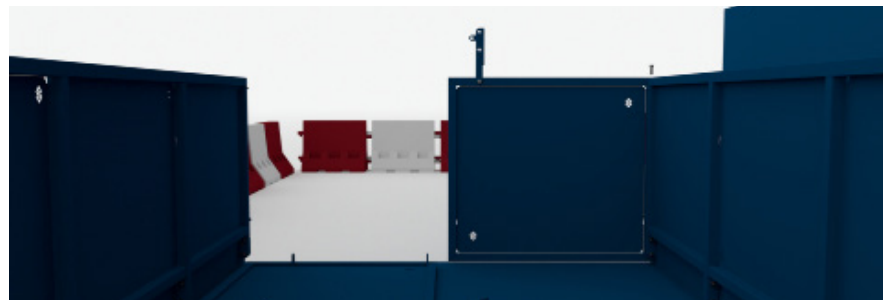

9. Screw Jacks are to be taken up to the install location separately.
10. Lift one door and hang it on its hinges using M16 bolt and Nylon nut connections. Ensure it can pivot on its hinges.
11. Repeat with the other door and then secure with the drop pin and latch.

12. Prop and Brace come pre-assembled ready for installation, lift into position and secure with bolts.



13. Prior to lifting, ensure tag lines are attached to the rear of the deck and in the opposite corner at the front of the deck near the top, so that they can be removed once installed.



14. Attach the 4 leg chain to the lifting points. The use of chain shorteners may be required to adjust the level of the deck.
15. Take the weight with the crane and lift until the platform sits clear of the ground. The deck should be lifted level.



18. Manoeuvre the deck as far back into the building as possible and lower onto the slab so that both beams are flat.



16. Ensure load path is clear and guide the deck into position on the edge of the building.
17. Use the tag lines to guide the platform into the building.



19. Install the Screw Jacks into the Props.
20. Remove the pin from the legs and slide the legs up so the head is approximately 100mm off of the slab.



21. Lift the deck high enough to position 2 short scaffold tubes under each leg. Secure with a tether around the legs.
22. Lower the deck onto the scaffold tubes and unlock the shot bolts on either side of the deck.

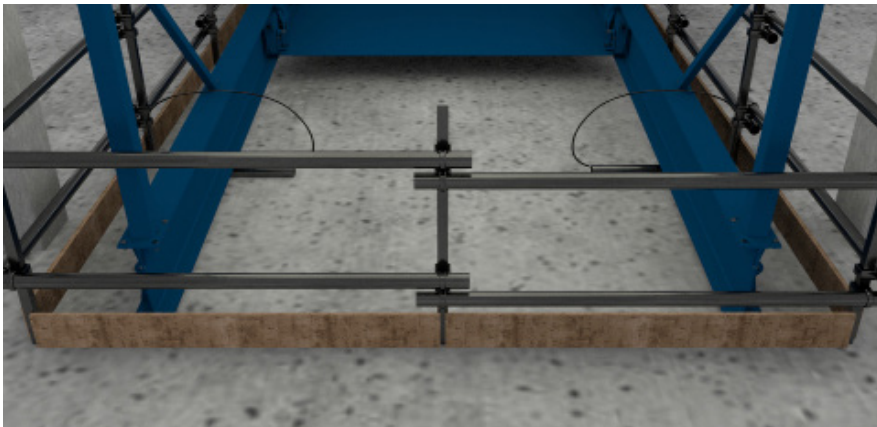

23. Roll the outer beams fully into the building so the front edge of the outer beams align with the slab edge.
24. Once fully extended lock into position with the shot bolts on both sides of the beam.



25. Holding the deck still, lift the deck up on the crane. The deck will tilt slightly back onto the slab allowing the scaffold tubes to be removed.
26. Lower the deck so that both beams are resting on the floor slab.

27. Remove the pin from the legs and slide the leg up until the head touches the slab.
28. Then lower the leg until the first hole is visible and re-insert the pin ensuring the safety pin is in place.
29. Ensure that the base beams are flat and the vertical legs are at 90° to the base beams.
30. Tighten the screw jacks until they are hand tight, then hammer just 1/4 turn extra. There must be no more than 150mm thread showing.





31. Check the screw jacks are tightly secured, slowly lower the crane down and disconnect the lifting chain.



33. Unlock both shot bolts on either side of the deck and roll into the building.



32. Remove the exclusion zone on the slab, ensuring that any gaps at the side of the deck are completed with edge protection.



34. Once fully into the building lock into position with the shot bolts on both sides at the rear of the beams.

35. The Super Roller CantiDeck is now successfully installed.

Original Working Instructions Usage Instructions

Rolled Out Removal Instructions

1. Unlock both shoot bolts on either side of the deck and roll out of the building.

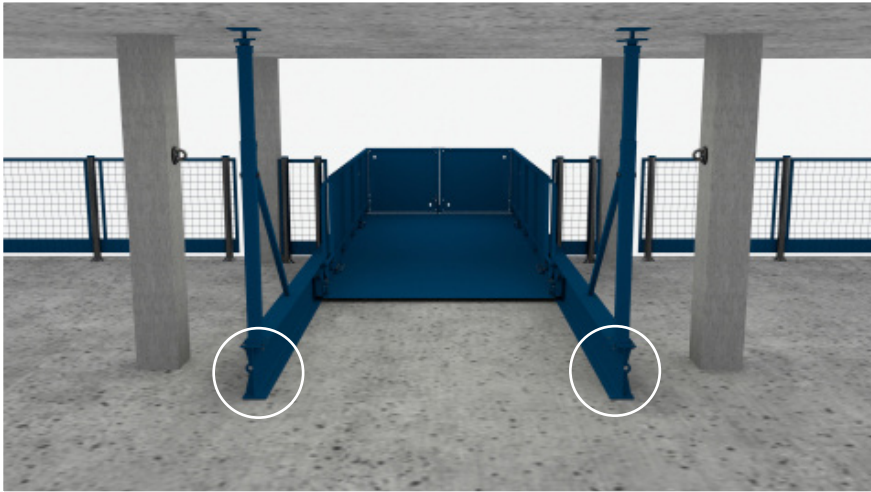

2. Once fully extended, lock into position with the shoot bolts on both sides into the outer beams.



3. Create exclusion zones around the deck and on the ground level below the deck.

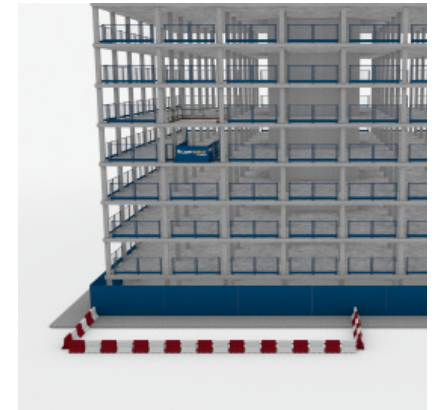
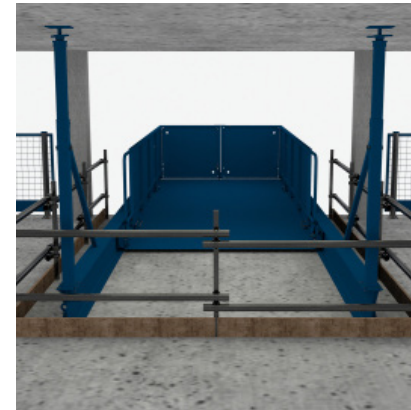

4. You will also require a suitable anchor point for the leading edge safety equipment to attach to.
5. Prior to lifting, attach a tag line to the front and rear of the deck in opposite corners.



6. Attach 2 chains to the outer lifting points (towards the doors), ensuring the 2 remaining chains are clipped out of the way.
7. Slowly take the weight of the deck, take care not to lift the deck until the props are released.

8. Remove the prop pin and lower the leg by 100mm minimum.



9. Insert the prop pin and replace the clip.

10. Lift the deck until you have a gap high enough to position 2 short scaffold tubes under each beam, securing with a tether.



11. Lower the deck slowly, as the weight of the deck sits on the scaffold tubes, slowly push the deck out by 1 meter.

12. Holding the deck still, lift the deck up on the crane to release the scaffold tubes.

13. Once they have been removed, lower the deck so that both beams are resting on the floor slab.

14. Remove the pin from the legs and slide the leg up until the head touches the slab.



15. Re-insert the pins ensuring the safety pin is in place and tighten the prop head to temporarily prop the deck.

16. Lower the crane so the building is taking the weight of the deck again.

17. Unclip the 2 unused chains and attach them to the to the lifting points closest to the building so all 4 chains are attached to the deck. You may need to shorten the chains so the deck lifts slightly tilted back (leg end down).



18. Slowly take the weight of the deck, take care not to lift the deck until the props have been released.



19. Loosen the prop heads from the soffit.

20. Remove the prop pin and lower the legs as far as possible.

21. Re-insert the prop pins and clips, then remove the prop heads.



22. Slowly lift the deck and manoeuvre it out of the building.



23. The deck can now be lowered to the ground to be made ready for transport or installed in a new location.

Original Working Instructions Usage Instructions

Rolled In Removal Instructions

1. Unlock both shoot bolts on either side of the deck and roll out of the building.



2. Once fully extended, lock into position with the shoot bolts on both sides into the outer beams.
3. Fit backup safety line securely in position on both sides of the deck.
4. Create exclusion zones around the deck and on the ground level below the deck.

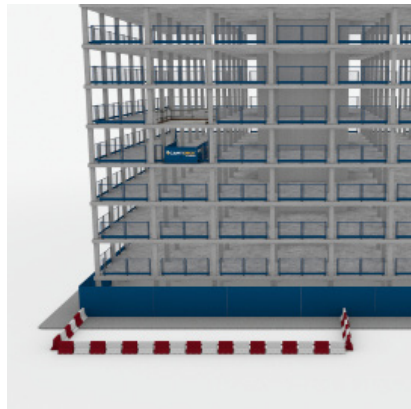

5. You will also require a suitable anchor point for the leading edge safety equipment to attach to.
6. Prior to lifting, attach a tag line to the front and rear of the deck in opposite corners.
7. Attach 1 leg of the 4 leg chains to each lifting point. You may need to shorten the chains so the deck lifts slightly tilted back (leg end down).



8. Slowly take the weight of the deck, take care not to lift the deck until the props are released.
9. Loosen the prop heads from the soffit.
10. Remove the prop pin and lower the legs by 100mm minimum.

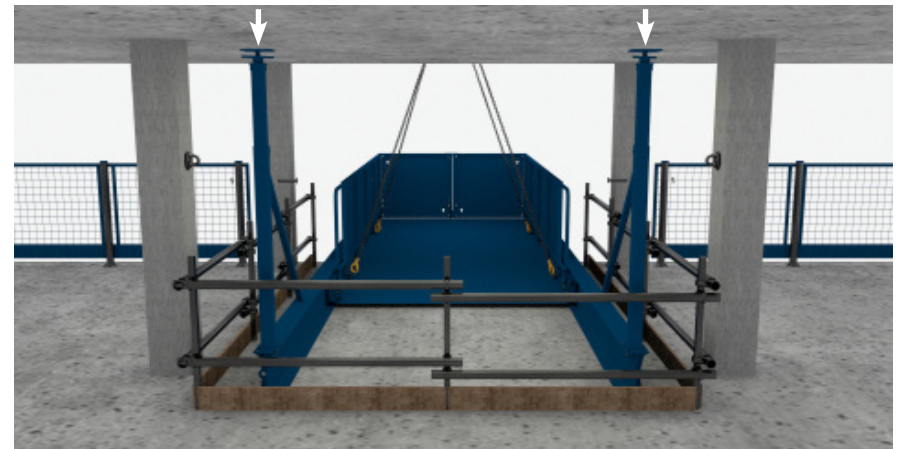

11. Re-insert the prop pin and replace the clip.
12. Lift the deck until you have a gap high enough to position 2 short scaffold tubes under each beam, securing with a tether.

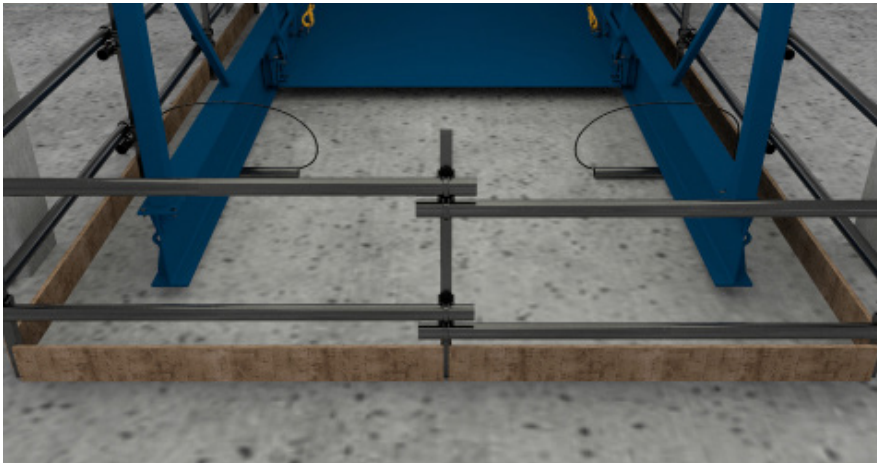

13. Lower the deck slowly, as the weight of the deck sits on the scaffold tubes.
14. Check backup safety line is securely fitted in position on both sides of the deck.
15. Release the shoot bolts on either side of the deck and carefully roll the outer beams out to close the deck fully.

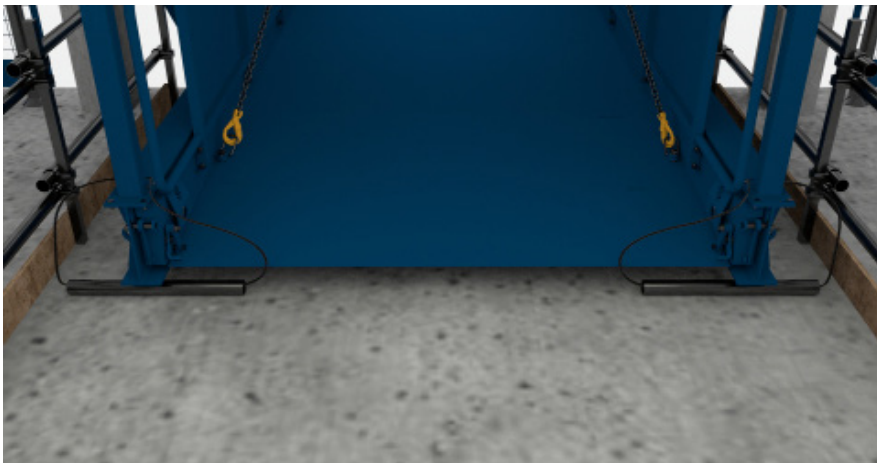

16. Holding the deck still, lift the deck up on the crane to release the scaffold tubes.

17. Once fully closed, lock the shoot bolts on both sides of the deck.
18. Slowly lift the deck and remove the scaffold tube rollers.
19. Lower the deck onto the slab so it is stable, remove the prop pins and lower the props as far as possible.



20. Re-insert the prop pins and clips, then remove the prop heads.
21. Slowly lift the deck and manoeuvre it out of the building.

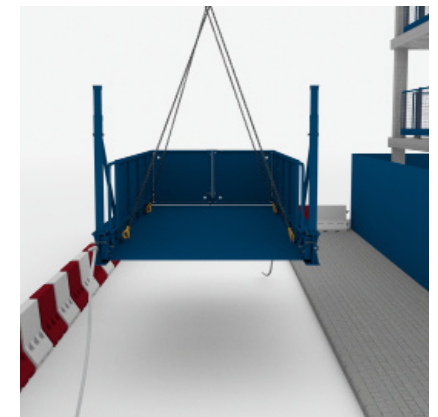

22. The deck can now be lowered to the ground to be made ready for transport or installed in a new location.

CANTIDECK SUPER ROLLER

PRE DELIVERY ASSESSMENT

Engineer to carry out full visual check on the following items to insure that they are correctly fitted in place and no damage or defects have occurred.

SERIAL NO:

PLATFORM SIZE:

ITEM TO CHECK	CHECKED
01 / Check base prop and leg assembly.	
02 / Check brace bar assembly.	
03 / Check prop head thread and wing handles.	
04 / Check handrail assembly.	
05 / Check sides, condition / complete (Including fixing bolts / pins).	
06 / Check doors, condition / complete (including safety pin) / locking assembly.	
07 / Check weld and wear for platform deck, beams and propping system.	
08 / Check all deck plate to inner beam bolts in place and complete (if applicable).	
09 / Check lifting eyes (and shackles x 4 if applicable).	
10 / Check all nuts and bolts are in place and tight.	
11 / Check rolling action.	
12 / Check platform ramp action.	
13 / Check deck locking bolt operation.	
14 / Check stopper and bolts for damage and fatigue.	

Other Notes

The above CantiDeck has been inspected according to the manufacturers recommendations and is safe to use:

DATE OF INSPECTION:

INSPECTED BY (SIGN):

(PRINT):

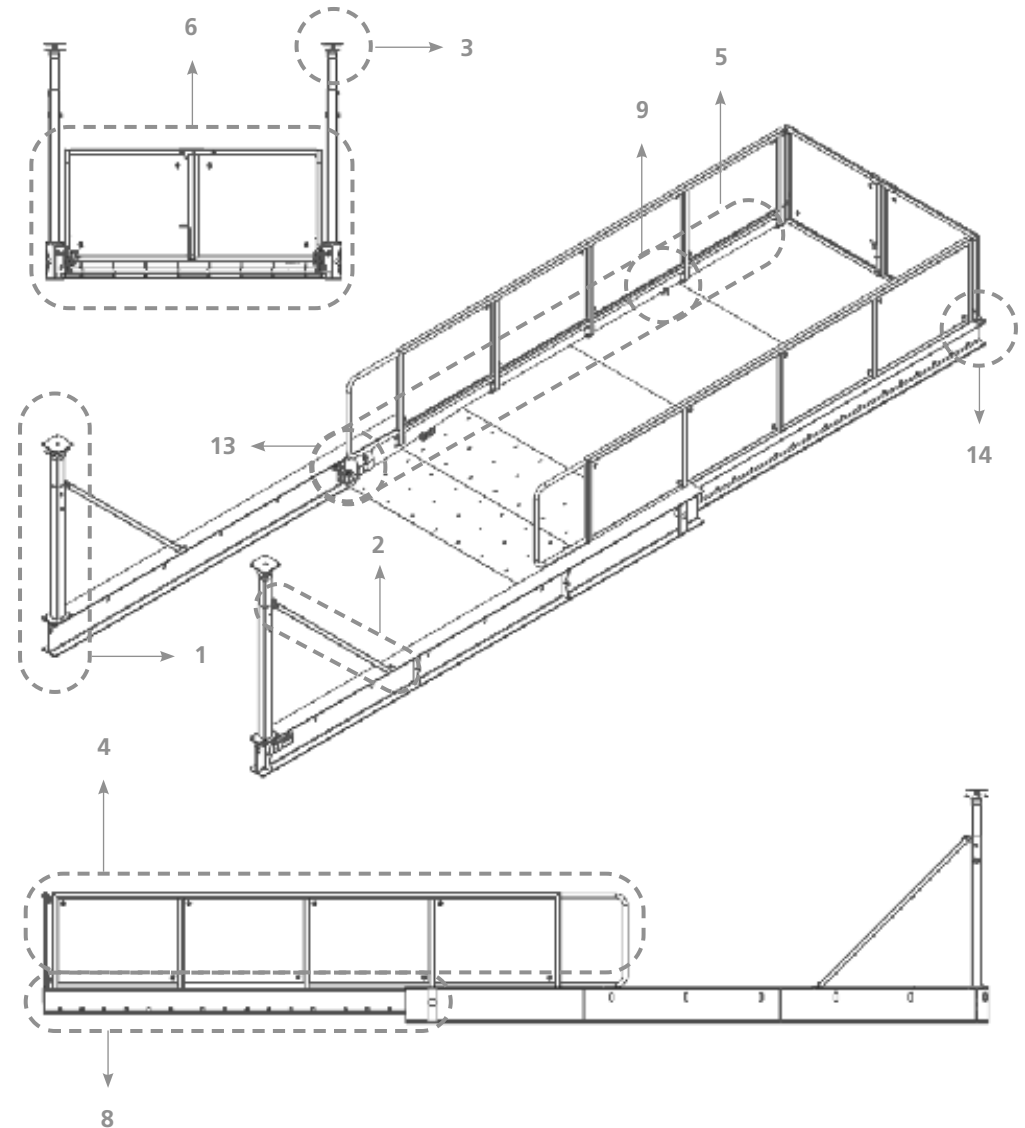

Original Working Instructions

Safety Instructions

Basic Safety

A site-specific Risk Assessment, and lift plan where applicable, must be completed by the responsible person before using this equipment to control risks, produce a safe system of work and ensure safety for you, your colleagues and others. Your risk assessment will determine the correct Personal Protective Equipment (PPE) for the task you are doing. You must use it. Conquip recommends that you should wear:

- Suitable clothing
- Gloves
- Hard hat
- Protective footwear (steel toecaps)
- Safety glasses



Important Safety Notes

- Read these instructions before using this equipment. If there is anything you do not understand or if you have any concerns do not use this equipment. Contact your supervisor or Conquip Engineering Group for advice.
- You must check that you have considered all the safety requirements for the task you are doing and that this equipment is suitable.
- You must protect bystanders and the general public by preventing access to the working area.
- Do not use this equipment if you are tired, unwell or under the influence of alcohol or drugs. If you are taking any medicine or undergoing treatment you should inform your supervisor.
- The doors on the end of the CantiDeck platforms could be a risk for possible unauthorised access or inadvertent opening. A control measure like a bolt or a padlock can be used to secure the doors shut. If you require this particular functionality, a risk assessment must be completed.

Usage & Transportation

- Never unevenly load this equipment.
- The weight of the equipment, together with its attachments, must be added to the weight of the load when calculating the total load that will be imposed on the lifting apparatus / operating machine.
- This equipment must be used in conjunction with the load ratings of the lifting apparatus / operating machine. (Refer to the manufacturers' load ratings and original working instructions).
- Make sure you know how to use this equipment and understand all aspects of its operation in case of emergency.
- This equipment weighs more than 25kg. Do not lift or manhandle without machine assistance.
- Do not operate this equipment near overhead power lines.
- Take care in confined spaces, near ceilings or similar hazards. This equipment was designed for vertical lifting. Do not drag, or swing.
- Before operating this equipment, check that you have enough space for you to work safely and make sure that the working area is clear of hazards, obstructions and personnel.
- Before lowering equipment make sure that the landing zone is clear and capable of accepting the size and weight of the load.
- Crush Risk. Keep hands and feet clear of the equipment at all times to avoid injury.
- Do not exceed the maximum Working Load Limit (WLL) shown on the serial plate. Ensure that the WLL on the individual lift points is not exceeded.
- Before lifting, check that the load is secured, balanced and stable. Allow space for the equipment to move if the load shifts.

Personnel

- All personnel must wear relevant personal protective equipment.
- Do not wear loose clothing or jewellery and tie back long hair to avoid becoming tangled or trapped in this equipment. You must make everyone in the work area aware of what you are doing.
- All personnel involved in the lifting operation must be competent to do so and must have been briefed in conjunction with this User Guide available from Conquip Engineering Group, the manufacturer.

Equipment Maintenance & Cleaning

- It is mandatory that the equipment is thoroughly examined regularly, by a qualified engineer, to ensure compliance with relevant regulation/s. (Conquip recommend to carry out thorough examination every six months).
- This product may incorporate various loose and detachable items of lifting gear. Refer to the separate requirements for the safe use of those items.
- When not being used, store the unit in a clean, upright condition and in a safe place where it will be protected from thieves and unauthorised users.
- This equipment must be inspected by the responsible person before each use and then regularly, as determined by your risk assessment or working practice. If you have any concerns about condition or suitability do not use.

Disclaimer

Warranty

The products supplied by Conquip Engineering Group are all guaranteed by a 12 month warranty.

Apart from where exceptions apply, Conquip Engineering Group promises to repair or replace any fault which the Company considers to be due to defective material or workmanship within 12 months of the date of sale, at no additional cost.

- Faults arising from unauthorised alterations (see modifications section below for full details).
- Damage caused by abuse, neglect, misuse or falling.
- Damage caused because of failure to follow transportation, storage, loading, cleaning or operating instructions.
- Replacement or repair of components due to fair wear and tear.
- Any consequential damage or wear arising from the use or fitting of additional or non-standard parts.

Modifications

If any third-party modifications or alterations, involving drilling, welding, cutting or distortion of materials in any form, are to be carried out on the product, Conquip Engineering Group must provide full written approval prior to the work being carried out.

Alterations, modifications, additions or repairs must be carried out by Conquip Engineering Group's recognised distributors, if they are not carrying out the work themselves.

Conquip Engineering Group operate a continuous improvement policy and therefore reserve the right to alter technical specifications and user guide details at any point without notice.

Conquip Engineering Group will not cover or reimburse any transportation and/or shipment costs to and from their premises or their recognised agents, or any material and/or labour costs for repair, replacement or assessment against a warranty claim.

Conquip Engineering Group and/or their directors, employees, insurers or recognised agents will not be held liable for consequential damages, losses or expenses relating to the inability to use the product correctly for its purpose.

EC Declaration of Conformity

In accordance with EN ISO 17050-1:2004

Declaration: As defined by the Machinery Directive 2006/42/EC and subsequent amendments

We, CONQUIP ENGINEERING GROUP, herewith declare that the following indicated equipment meets the fundamental health and safety requirements concerning the EU guide line(s), due to their design and manufacture.

This declaration will be rendered null and void if the machine is changed without our approval.

Signed:



Dated: 2024

Garry Critchley, Managing Director

Product Code(s):

SR22 / SR29 / SR35

EC Directive/ Regulation:

2006/42/EC,
Lifting Operations and Lifting Equipment Regulations 1998
Provision and Use of Work Equipment Regulations 1998

Harmonised Standards:

BS EN ISO 12100:2010
BS EN 13155

General Description/ Designation:

CantiDeck Super Roller 22 – SR22
CantiDeck Super Roller 29 – SR29
CantiDeck Super Roller 35 – SR35

WLL:

SR22, SR29, SR35 = 5000kg

Important Notes

- This User Guide is for this Conquip product only.
- Any movements of the product must be thoroughly planned before the work commences to identify potential hazards and assess risk.
- All personnel involved in lifting and transportation of this product must have read this User Guide and must be properly briefed.
- You must be competent, alert and medically fit when using this equipment. If you have a medical condition, a mental or physical disability, you must seek advice from a medical professional before using this equipment.

Talking to us is easy

We're here to help

Call us on +44 (0) 333 300 3470

Email us at sales@cqegroup.com

www.cqegroup.com

Conquip Engineering Group

Waterbrook Estate, Alton, Hampshire, GU34 2UD

Copyright © 2024 Conquip Engineering Group. All Rights Reserved.
User Guide - CantiDeck Super Roller - Issue 5