

USER GUIDE

BOAT SKIP

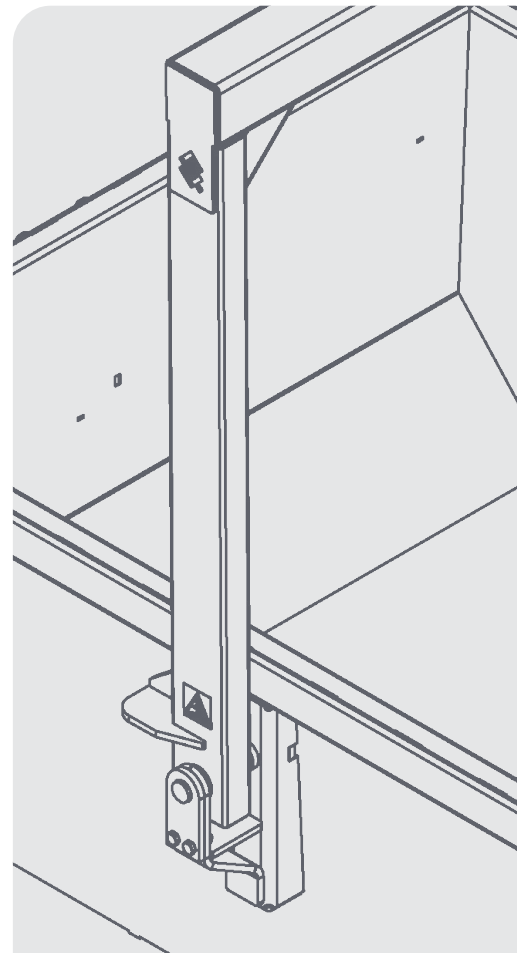
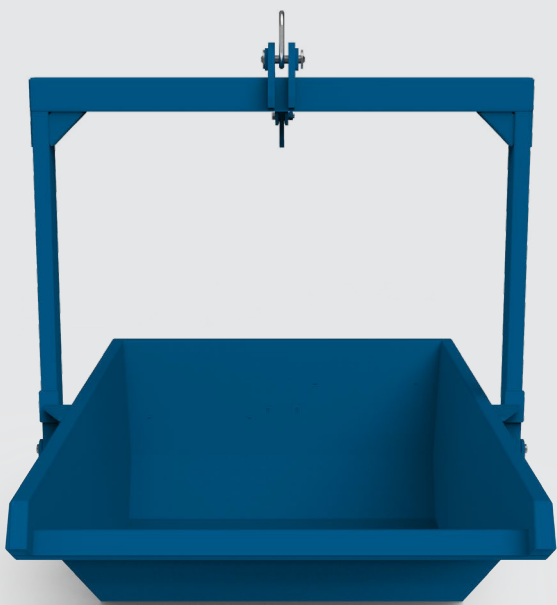

DISCLAIMER

Do not attempt to handle or operate this equipment before you have received sufficient training. Before use, operatives must have carried out all checks featured on the Visual Inspection Sheet on page 11. It is imperative that you have read the General Safety Instructions on page 12 and sufficiently familiarised yourself with the Operational Procedures in this document.

Note that this item is compliant only to the standards specified in this User Guide and it is therefore the duty of the responsible person(s) to review and ensure compliance.

CONTENTS

PRODUCT INFORMATION

INTRODUCTION	05
SPECIFICATION	06

OPERATIONAL PROCEDURES

IMPORTANT USAGE NOTES	08
AUTOMATIC LOCKING MECHANISM INSTRUCTIONS	08
LOADING & EMPTYING INSTRUCTIONS	08

MAINTENANCE & INSPECTION

MAINTENANCE REGIME	10
VISUAL INSPECTION SHEET	11

GENERAL SAFETY INSTRUCTIONS

SAFETY INSTRUCTIONS	12
GENERAL NOTES	13

LEGAL

TERMS AND CONDITIONS	14
EC DECLARATION OF CONFORMITY	18
STANDARDS AND REGULATIONS APPLICABLE	19

INTRODUCTION

OVERVIEW

The Conquip Boat Skip is for general muck and waste removal. The range of capacities and robust design make it ideal for transporting a variety of loads. A low loading height and drop-down bale arm ensure loading is quick and easy.

Designed with a 'dog bone' mechanism for the automatic emptying of the skip by the crane operator, it eliminates the need for an assistant to manually operate it.

KEY BENEFITS

- Automatic unloading eliminates the need for an assistant and for the slinger or signaller to enter the 'danger zone'.
- Lifts and tips part loads, a physical impossibility with traditional, manually operated, circular muck skips.
- Available in a wide range of capacities, from 500 to 2000 litres.
- Available with a debris cover on request to keep dust pollution to a minimum.

SPECIFICATION

THE RANGE

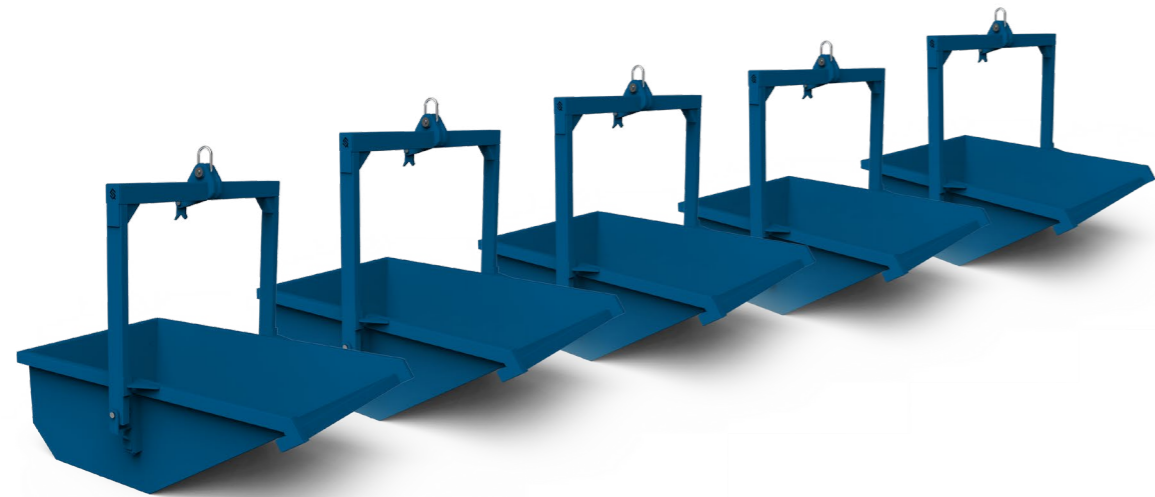

CODE	TYPE	WEIGHT (kg)	WLL* (kg)	CAPACITY (litres)
CA108-00500	Boat Skip 500	130	1000	500
CA108-00750	Boat Skip 750	235	1500	750
CA108-01000	Boat Skip 1000	255	2000	1000
CA108-01500	Boat Skip 1500	425	3000	1500
CA108-02000	Boat Skip 2000	540	4000	2000

*Working Load Limit

SPECIFICATION

ITEM	PRODUCT CODE
Boat Skip 500	CA108-00500
Boat Skip 750	CA108-00750
Boat Skip 1000	CA108-01000
Boat Skip 1500	CA108-01500
Boat Skip 2000	CA108-02000

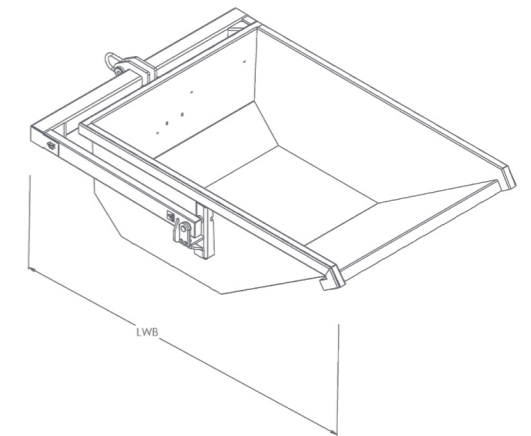
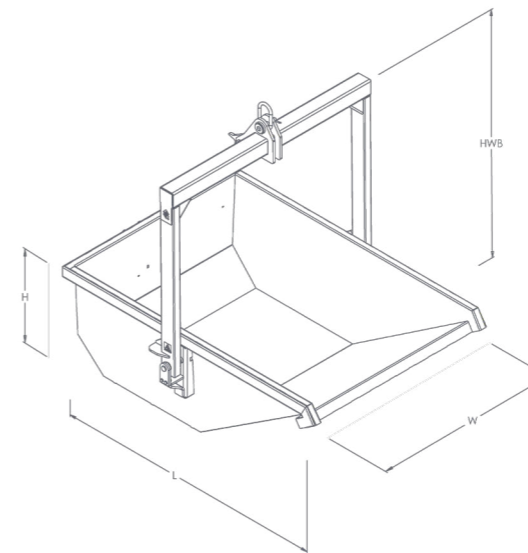

LENGTH (mm)	LWB ¹ (mm)	WIDTH (mm)	HEIGHT (mm)	HWB ² (mm)
1520	1690	1360	530	1410
1595	1780	1710	560	1450
1955	2135	1555	640	1720
2187	2390	1885	665	1815
2355	2555	1835	880	2180

¹ LWB = Length With Bale
² HWB = Height With Bale

OPERATIONAL PROCEDURES

IMPORTANT USAGE NOTES

- When attaching to lifting equipment, always ensure that the hook's gate is correctly closed and the lifting eye is seated correctly in the hook.
- Do not use the Boat Skip for carrying toxic or dangerous materials or chemicals or light fires in or around the skip.
- Do not overfill the skip by volume or weight, the load should be evenly placed.
- At no point during the operation of this skip should personnel be within the discharge zone.
- All of the lifting, tipping and manoeuvring must be carried out by a crane. Do not attempt to move the skip or the bale arm by hand.
- The Boat Skip is for lifting and transporting waste and materials only. Do not use to raise or transport personnel.

AUTOMATIC LOCKING MECHANISM INSTRUCTIONS

- The Boat Skip is fitted with a lock and release system. The lock is situated at the rear of the skip and engages with the catch fitted to the top of the lifting arm.
- When the lifting arm is lowered fully, it will engage with the locking system. When next raised, the skip will rise and discharge its load.
- When fully lowered a second time, the lifting arm will disengage from the locking system, allowing the unit to be raised and manoeuvred to the loading bay.
- If the lifting arm is out of sequence (locked when it should be unlocked), simply raise the lifting arm, then lower to release the catch.

LOADING & EMPTYING INSTRUCTIONS

- Attach the lifting equipment's hook to the skip's bale arm lifting point, with the bale arm in the lowered position.
- Carry out a test lift with the unit empty to ensure that both the slinger or signaller and the crane operator are familiar with the correct and safe operation of the Boat Skip and fully understand how the locking mechanism functions, the tipping action is carried out and the reactions of the skip to these actions.
- Raise the crane to bring the lifting arm upright and lift the unit just off the ground.
- Check that the skip is balanced correctly before lowering back to the ground. The Boat Skip is now ready for use.

- Position the unit on firm level ground, which is able to bear the unit's weight and load. Lower the bale arm.

- Evenly fill the skip, ensuring the load is no wider, longer or higher than the skip's side walls.

- Cover the load in the skip with a debris cover, by pulling the cover over the load and fasten on all four sides by hooking the rope around each of the welded hooks. It is recommended that the load is covered with a debris cover to safeguard against any of the load falling from the skip.

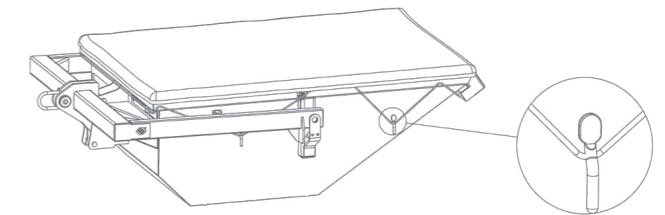

- Once loaded and ready, clear all personnel from the area, and raise the skip off the ground to check that the load is balanced and secure. The skip can now be craned to the discharge area.

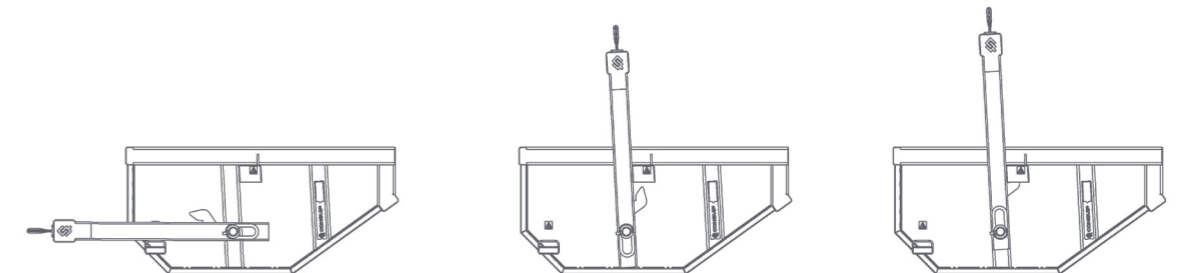

- Ensure that no personnel are in the discharge area, lower the skip to the ground with the front facing the discharge area.

- Lower the lifting arm fully to allow the locking system to engage.

- Remove the debris cover.

- Once ready, raise the lifting hook to tip the skip and discharge the load.

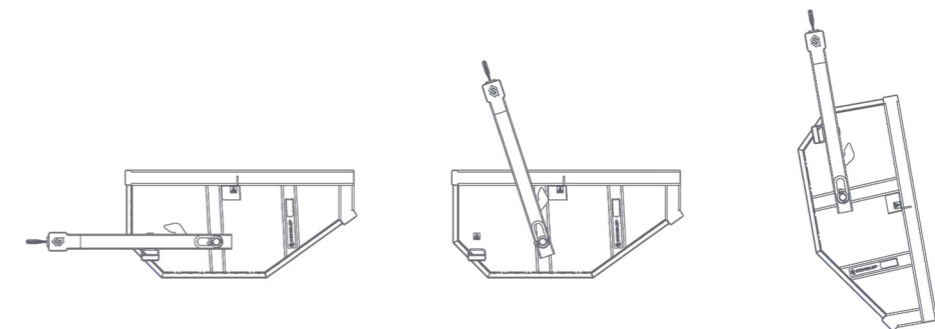

- Having emptied the skip, lower it back to the ground to allow the lifting arm to disengage from the locking system before once again raising the skip and moving to the loading area.

- Once empty and lowered, lower the bale arm to its lowered position and detach it from the lifting equipment.

MAINTENANCE & INSPECTION

MAINTENANCE REGIME

- It is mandatory that the equipment is thoroughly examined regularly, by a qualified engineer, to ensure compliance with relevant regulations. Conquip recommend carrying out a thorough examination every six months.
- This equipment may incorporate various loose and detachable items including, but not limited to pins, bolt assemblies and adaption plates. Refer to the separate requirements for the safe use of those items.
- When not being used, store the unit in a clean, upright condition and in a safe place where it will be protected from thieves and unauthorised users.
- This equipment must be inspected by the responsible person before each use and then regularly, as determined by your risk assessment or working practice. If you have any concerns about the equipment's condition or suitability, do not use it.

VISUAL INSPECTION CHECKLIST

INSPECTION ITEMS	RESULTS		COMMENTS
	SATISFACTORY	UNSATISFACTORY	
Serial Number			CQ.....
Product Code			
Working Load Limit (kg)			
Conforms to user guide specification			
Check lock and release system for wear			
Check bale arm for bends or twisting			
Check bale arm returns to horizontal safe position			
Inspect lift pins and locking device for wear			
Inspect shackle for wear and ensure split pin fitted			
Check safety chain device for bale arm			
General visual inspection of the body			
SIGNATURE			
Name	Position	Qualification	Signature & Date

GENERAL SAFETY INSTRUCTIONS

The machinery should be properly operated and maintained to keep it in a safe, efficient operating condition. Be sure that all fixings and components are free of mud or other matter that might cause issues hazardous to the operator, serviceman, or other personnel or equipment. Report all malfunctions to those responsible for maintenance, and do not operate the equipment until corrected. Normal service or maintenance performed as required can prevent unexpected and unnecessary downtime.

This operations manual describes general inspections, servicing and operation with the normal safety precautions required for normal servicing and operating conditions. It is not a guide, however, for abnormal conditions or situations, and therefore, servicemen and operators must be safety conscious and alert to recognise potential servicing or operating safety hazards at all times, and take necessary precautions to assure safe servicing and operation of the machine.



M002
Refer to instructions manual



M004
Wear eye protection



M008
Wear safety footwear



M009
Wear protective gloves



M010
Wear protective clothing



M014
Wear head protection



M015
Wear high-visibility clothing

GENERAL NOTES

- Read this operations manual and learn the operating characteristics and limitations of the machinery. Know what operating clearances the machine requires.
- Read and understand all the safety signs prior to operation.
- If the safety signs are obstructed by dirt or debris, clean them using mild soap and water prior to operation.
- If the safety signs are damaged or illegible, replace them immediately, prior to operation.
- Be aware of operating hazards that weather changes can create on the job. Know proper procedures to follow when a severe rain or electrical storm strikes.
- Never attempt to operate or work on machinery when not feeling physically fit.
- Never wear loose clothing, rings, watches, heavy gloves etc., that might catch and result in injury.
- Know what safety equipment is required and use it. Such equipment may be: hard hat, safety glasses, reflector type vests, protective gloves and safety footwear.

TERMS & CONDITIONS

CONQUIP ENGINEERING GROUP STANDARD PRODUCT WARRANTY

01. COMMENCEMENT

1.1 This Warranty shall commence on the Commencement Date and shall continue until the earlier of:

- (a) the Expiry Date; or
- (b) the date on which it may be voided in accordance with clause 4.1(b)

when it shall terminate automatically without notice.

02. DUTY OF GOOD FAITH

2.1 The Purchaser shall in the exercise of its rights under this Warranty and in the compliance with its obligations under this Warranty be subject to and shall in all respects owe and comply with a duty of good faith to the Warrantor.

03. NATURE AND EXTENT OF COVER

3.1 Subject to clause 3.2 the Warrantor agrees and undertakes to the Purchaser that it shall be liable to the Purchaser under and in accordance with the terms of this Warranty in the event that:

- (a) prior to the Expiry Date the Purchaser shall notify a Warranty Claim to the Warrantor; and
- (b) the Equipment or any relevant part of the Equipment shall have become unusable as the result of defective material or defective workmanship prior to the Expiry Date.

3.2 The Warrantor's obligation under clause 3.1 shall be expressly subject to the provisions of clauses 4, 5 and 6 and conditional upon the Purchaser's compliance in full with the provisions of clause 7.

04. RESTRICTIONS

4.1 The following restrictions apply to this Warranty:

(a) This Warranty is personal to the Purchaser and neither the legal benefit nor legal burden of this warranty may be assigned or novated or otherwise transferred by the Purchaser to any other party. Any purported assignment, novation or transfer shall not be binding upon the Warrantor.

(b) This Warranty shall be void in the event that the Purchaser:

(i) cannot provide authentic and original documentary evidence that the Purchaser has during the period between the Commencement Date and the Expiry Date complied with the Maintenance and Servicing Requirements; and/or

(ii) has, during the period between the Commencement Date and the Expiry Date, exceeded the Purchaser's Usage Cycle Parameters; and/or

(iii) has, during the period between the Commencement Date and the Expiry Date, exceeded the Purchaser's Use Parameters; and/or

(iv) has carried out, or procured the carrying out by any third party of, any repair to the Equipment or any part of the Equipment which is not an Authorised Repair; and/or

(v) has operated the Equipment after having replaced any part of the Equipment with a part which has not been supplied and fitted by the Warrantor; and/or

(vi) has modified the Equipment in any way prior to use.

05. EXCLUSIONS

5.1 The following are excluded from the scope of this Warranty:

(a) Loss of and/ or damage to the Equipment or any part of it resulting from any collision between the Equipment and any other fixed or stationary or mobile object whatsoever, irrespective of whether that collision was or was not caused by the Purchaser; and/or

(b) Loss of and/or damage to any personal property and/or possessions or other equipment not forming part of the Equipment but which is present in or about the Equipment; and/or

(c) loss and/or damage which is covered by any other insurance policy taken out and maintained by the Purchaser or in respect of which the Purchaser has a contractual obligation to do so; and/or

(d) loss and/or damage to the equipment which is consistent with the use by the Purchaser of the Equipment:

(i) in compliance with the Maintenance and Servicing Requirements; and

(ii) in compliance with the Usage Cycle Parameters; and

(iii) in compliance with the Use Parameters; and

(iv) having only carried out Authorised Repairs to the Equipment; and

(v) having all and any replacement parts fitted by the Warrantor; and

(vi) in unmodified form.

06. LIMITATION OF LIABILITY

6.1 The Warrantor's liability to the Purchaser shall be limited as follows:

- (a) The Warrantor shall not in any circumstances be liable to the Purchaser for indirect and/or consequential and/or economic loss suffered and/or incurred as the case may be by the Purchaser; and
- (b) The Warrantor shall only be liable to the Purchaser for the reasonable and proper costs reasonably and properly incurred by the Purchaser directly in connection with the repair and/or replacement (at the Warrantor's absolute discretion) of the Equipment or any part of the Equipment; and
- (c) The Warrantor's liability to the Purchaser shall notwithstanding any other provision of this Warranty, not in any circumstances exceed the Purchase Price of the Equipment.

07. WARRANTY CLAIMS

7.1 The Purchaser shall in respect of any claim against the Warrantor under this Warranty and within 24 hours of the occurrence of the subject matter of the Warranty Claim:

- (a) Complete in full and submit to the Warrantor a Warranty Claim in the form annexed to Schedule 4;
- (b) Provide date stamped or date identifiable photographs evidencing the claim; and
- (c) Make the Equipment or the relevant part of the Equipment available to the Warrantor for inspection within 48 hours of notification of the relevant Warranty Claim.

08. ENTIRE AGREEMENT

8.1 This Warranty constitutes the entire agreement between the parties and supersedes and extinguishes all previous promises, assurances, warranties, representations and understandings between them, whether written or oral, relating to its subject matter.

8.2 Each party agrees that it shall have no remedies in respect of any statement, representation, assurance or warranty (whether made innocently or negligently) that is not set out in this Warranty. Each party agrees that it shall have no claim for innocent or negligent misrepresentation or negligent misstatement based on any statement in this Warranty.

No variation of this Warranty shall be effective unless it is in writing and signed by the parties (or their authorised representatives).

09. WAIVER

No failure or delay by a party to exercise any right or remedy provided under this Warranty or by law shall constitute a waiver of that or any other right or remedy, nor shall it prevent or restrict the further exercise of that or any other right or remedy. No single or partial exercise of such right or remedy shall prevent or restrict the further exercise of that or any other right or remedy.

10. SEVERANCE

10.1 If any provision or part-provision of this Warranty is or becomes invalid, illegal or unenforceable, it shall be deemed deleted, but that shall not affect the validity and enforceability of the rest of this Warranty.

10.2 If any provision or part-provision of this Warranty is deemed deleted under clause 10.1 the parties shall negotiate in good faith to agree a replacement provision that, to the greatest extent possible, achieves the intended commercial result of the original provision.

11. THIRD PARTY RIGHTS

11.1 This Warranty does not give rise to any rights under the Contracts (Rights of Third Parties) Act 1999 to enforce any term of this Warranty.

12. GOVERNING LAW

12.1 This Warranty and any dispute or claim (including non-contractual disputes or claims) arising out of or in connection with it or its subject matter or formation shall be governed by and construed in accordance with the law of England and Wales.

13. JURISDICTION

13.1 Each party irrevocably agrees that the courts of England and Wales shall have exclusive jurisdiction to settle any dispute or claim (including non-contractual disputes or claims) arising out of or in connection with this Warranty or its subject matter or formation.

EC DECLARATION OF CONFORMITY

IN ACCORDANCE WITH EN ISO 17050-1:2004

Declaration: As defined by the Machinery Directive 2006/42/EC and subsequent amendments

We, CONQUIP ENGINEERING GROUP, herewith declare that the following indicated equipment meets the fundamental health and safety requirements concerning the EU guideline(s), due to their design and manufacture.

This declaration will be rendered null and void if the machine is changed without our approval.

SIGNED:



DATED: 2024

Garry Critchley, Chief Executive Officer

PRODUCT CODES	GENERAL DESCRIPTION / DESIGNATION	WORKING LOAD LIMIT
CA108-00500	Boat Skip 500	1000kg
CA108-00750	Boat Skip 750	1500kg
CA108-01000	Boat Skip 1000	2000kg
CA108-01500	Boat Skip 1500	3000kg
CA108-02000	Boat Skip 2000	4000kg

ITEM	CODE	DESCRIPTION
EC DIRECTIVE/REGULATION	2006/42/EC	Directive 2006/42/EC- new machinery directive
HARMONISED STANDARDS	BS EN ISO 12100:2010	Safety of machinery General principles for design Risk assessment and risk reduction
OTHER REGULATIONS	LOLER 1998	Lifting Operations and Lifting Equipment Regulations 1998 (LOLER)
	PUWER 1998	Provision and Use of Work Equipment Regulations 1998 (PUWER)

TALKING TO US IS EASY
WE'RE HERE TO HELP

Call us on 0333 300 3470
Email us at sales@cqegroup.com
www.cqegroup.com

