

USER GUIDE

SAFETY BRIEFING STATION

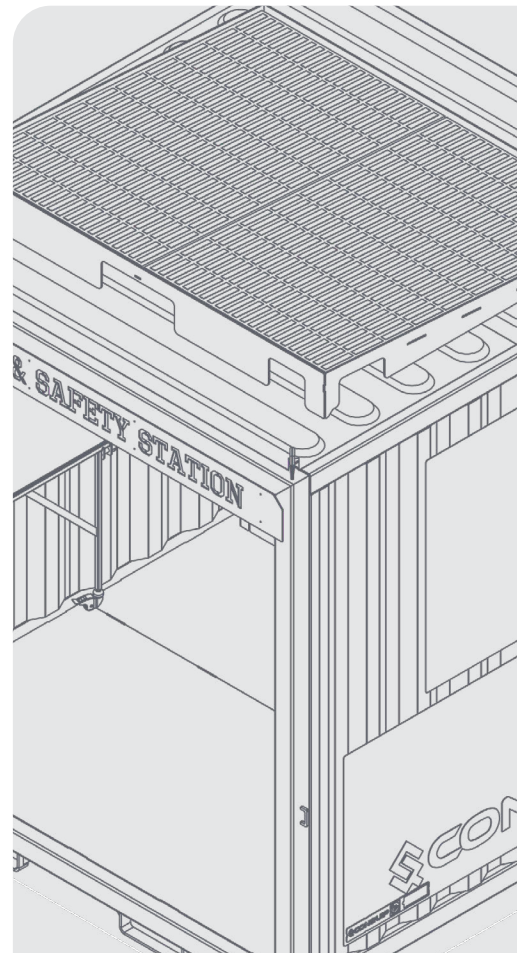

DISCLAIMER

Do not attempt to handle or operate this equipment before you have received sufficient training. Before use, operatives must have carried out all checks featured on the Visual Inspection Sheet on page 11. It is imperative that you have read the General Safety Instructions on page 12 and sufficiently familiarised yourself with the Operational Procedures in this document.

Note that this item is compliant only to the standards specified in this User Guide and it is therefore the duty of the responsible person(s) to review and ensure compliance.

CONTENTS

PRODUCT INFORMATION

INTRODUCTION	04
SPECIFICATION	05
PARTS DIAGRAM	06

OPERATIONAL PROCEDURES

IMPORTANT USAGE NOTES	08
TO EXPAND THE WHITEBOARD	08
LIFTING WITH A FORKLIFT	08
LIFTING WITH A CRANE	09

MAINTENANCE & INSPECTION

MAINTENANCE REGIME	10
VISUAL INSPECTION SHEET	11

GENERAL SAFETY INSTRUCTIONS

SAFETY INSTRUCTIONS	12
GENERAL NOTES	13

LEGAL

TERMS AND CONDITIONS	14
EC DECLARATION OF CONFORMITY	18
STANDARDS AND REGULATIONS APPLICABLE	19

INTRODUCTION

OVERVIEW

A multi-functional unit for site personnel.

The Safety Briefing Station is a robust, weather-proof container, designed as a hub for all site operatives. It features built-in cabinets for first aid kits, fire extinguisher bins, a removable locking panel to enclose solar batteries, and a sign-in area for personnel.

Magnetic, fold-out whiteboards can be used for daily team briefings and recording any important site information. Lifting points and fork pockets ensure the Safety Briefing Station can be easily manoeuvred around site.

KEY BENEFITS

- Built-in cabinets for first aid kits.
- Fire extinguisher bins.
- Removable locking panel to enclose solar batteries.
- Sign-in area for personnel.
- Magnetic, fold-out whiteboards for daily staff briefings.
- Lifting points and fork pockets for easy manoeuvre around site.

SPECIFICATION

ITEM	PRODUCT CODE
Safety Briefing Station	SS905-17389

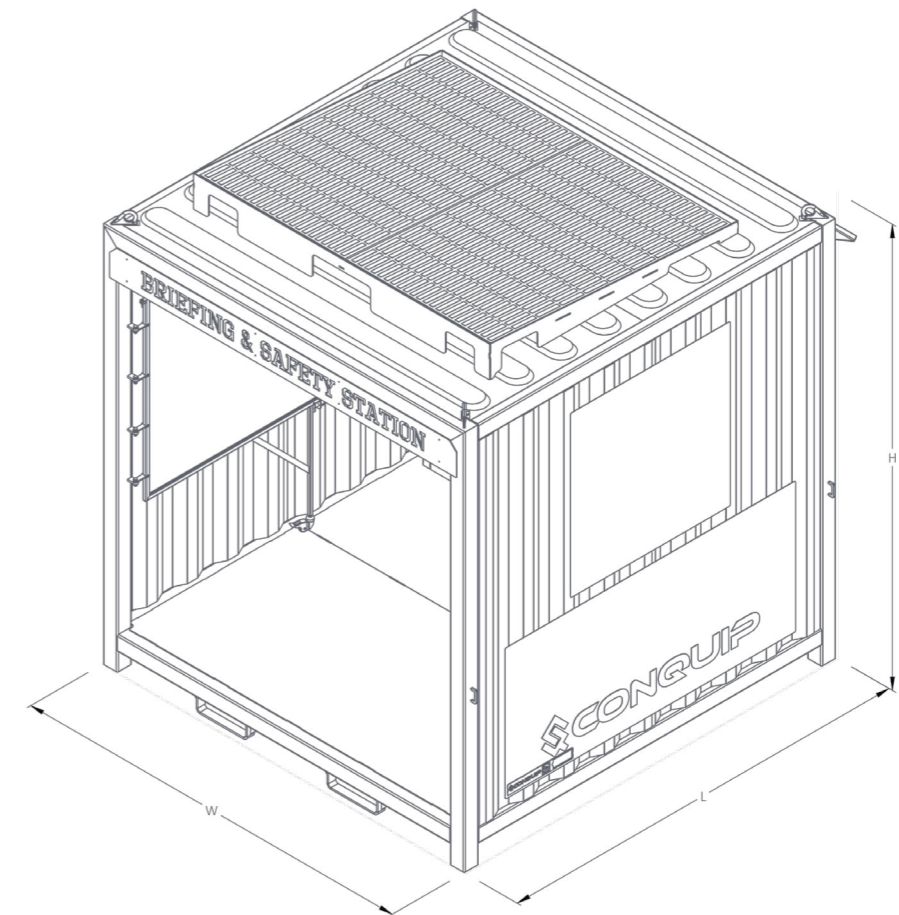

CODE	LENGTH (mm)	WIDTH (mm)	HEIGHT (mm)	WEIGHT (kg)	WLL* (kg)
SS905-17389	2760	2610	2840	2170	Self-Weight

*Working Load Limit

PARTS DIAGRAM

SAFETY BRIEFING STATION

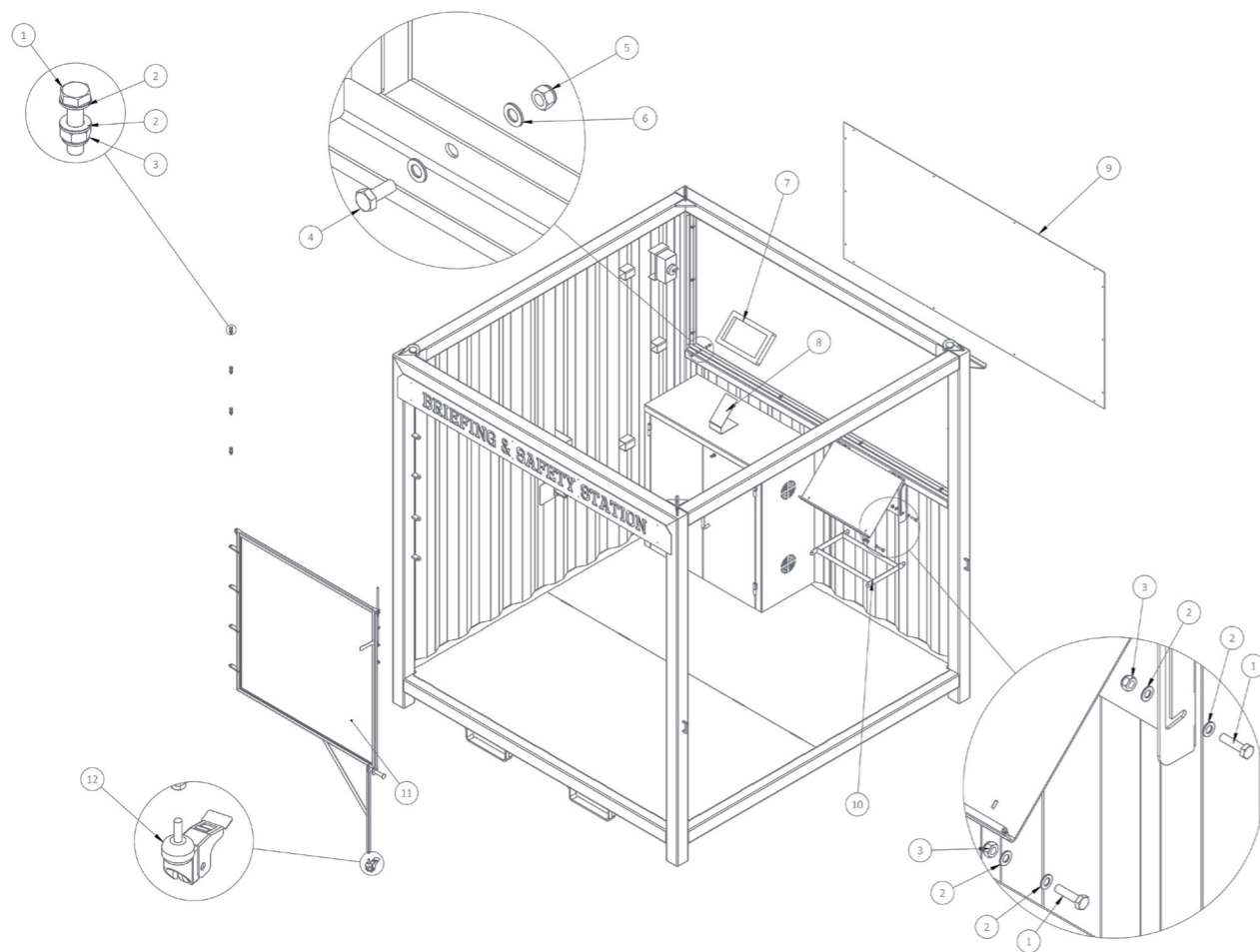

PARTS DIAGRAM

SAFETY BRIEFING STATION

ITEM NUMBER	PART	DESCRIPTION	QUANTITY
1	M10x40	M10x40 Hex Head Set Screw	4
2	NS800018	M10 Flat Washer	8
3	NS800013	M10 Nyloc Nut	4
4	NS800160	M8x20 Hex Head Set Screw	14
5	NS800235	M8 Flat Washer	28
6	NS800011	M8 Nyloc Nut	14
7	ZZ960236	IPad Pro Secured Enclosure	1
8	ZZ960237	45 Degree Kiosk Mount Bracket Stand	1
9	SS905-17389-04	Perspex Screen 2278x1030mm	1
10	SS905-17389-09	Fold Away Board Hinge Assembly	1
11	SS905-17389-10	Whiteboard Assembly	1
12	ZZ960238	50mm Swivel Castor	1

NOTE: These parts are for this model, they may differ for previous versions. Please contact Conquip with any queries.

OPERATIONAL PROCEDURES

IMPORTANT USAGE NOTES

- Do not stack units.
- Before lifting, ensure:
 - The whiteboard is latched against the inside wall.
 - Enclosures for first aid kit, eyewash kit, burns kit and defibrillator are closed.
 - The sign-in tray is stowed vertically.
 - The tablet unit is locked.
 - Nothing is loose in the container.

TO EXPAND THE WHITEBOARD

01. Unlatch the hook holding the whiteboard against the side wall.
02. Pull the whiteboard towards the front until it is parallel with the front of the unit.
03. Use the latch to secure the whiteboard at the top and apply the brake to the castor at the bottom.
04. When done, undo the latch and the castor brake.

LIFTING WITH A FORKLIFT

01. To lift the Safety Briefing Station with a forklift, set the machine's forks to the correct width for the fork pockets. Make sure that they are equidistant from the centre.
02. Drive the forklift to the Safety Briefing Station, aligning the forks with the fork pockets.
03. Move the forklift forward until the forks are fully inserted into the fork pockets. The Safety Briefing Station is now ready to move.
04. Carefully raise the unit just off the ground and check for balance and security.
05. Transport the Safety Briefing Station to its required destination, taking care not to jolt the load.
06. When in position, the unit can be lowered onto flat, firm, level ground.
07. Reverse the forklift back and clear of the Safety Briefing Station.

LIFTING WITH A CRANE

01. Attach the crane, or other suitable lifting apparatus to the Safety Briefing Station's four lifting points, using a certified four-leg lifting chain. Ensure the hook's gate is correctly closed and the lifting eye is seated correctly in the hook.
02. Check that personnel are clear from the immediate area and the intended location. Allow for the Safety Briefing Station swinging when lifting off the ground.
03. Carefully raise the Safety Briefing Station just off the ground and check for balance and security.
04. Carefully transport the unit to its required destination.
05. When in position, the Safety Briefing Station can be lowered onto flat, firm, level ground.
06. Detach the lifting equipment from the Safety Briefing Station.

MAINTENANCE & INSPECTION

MAINTENANCE REGIME

- It is mandatory that the equipment is thoroughly examined regularly, by a qualified engineer, to ensure compliance with relevant regulations. Conquip recommend carrying out a thorough examination every six months.
- This equipment may incorporate various loose and detachable items including, but not limited to pins, bolt assemblies and adaption plates. Refer to the separate requirements for the safe use of those items.
- When not being used, store the unit in a clean, upright condition and in a safe place where it will be protected from thieves and unauthorised users.
- This equipment must be inspected by the responsible person before each use and then regularly, as determined by your risk assessment or working practice. If you have any concerns about the equipment's condition or suitability, do not use it.

VISUAL INSPECTION CHECKLIST

INSPECTION ITEMS	RESULTS		COMMENTS
	SATISFACTORY	UNSATISFACTORY	
Serial Number			CQ.....
Product Code			
Working Load Limit (kg)			
Conforms to user guide specification			
General visual inspection of the body			
SIGNATURE			
Name	Position	Qualification	Signature & Date

GENERAL SAFETY INSTRUCTIONS

The equipment should be properly operated and maintained to keep it in a safe, efficient operating condition. Be sure that all fixings and components are free of mud or other matter that might cause issues hazardous to the operator, serviceman, or other personnel or equipment. Report all malfunctions to those responsible for maintenance, and do not operate the equipment until corrected. Normal service or maintenance performed as required can prevent unexpected and unnecessary downtime.

This operations manual describes general inspections, servicing and operation with the normal safety precautions required for normal servicing and operating conditions. It is not a guide, however, for abnormal conditions or situations, and therefore, servicemen and operators must be safety conscious and alert to recognise potential servicing or operating safety hazards at all times, and take necessary precautions to assure safe servicing and operation of the equipment.



M002
Refer to instructions manual



M004
Wear eye protection



M008
Wear safety footwear



M009
Wear protective gloves



M010
Wear protective clothing



M014
Wear head protection



M015
Wear high-visibility clothing

GENERAL NOTES

- Read this operations manual and learn the operating characteristics and limitations of the equipment.
- Read and understand all the safety signs prior to operation.
- If the safety signs are obstructed by dirt or debris, clean them using mild soap and water prior to operation.
- If the safety signs are damaged or illegible, replace them immediately, prior to operation.
- Be aware of operating hazards that weather changes can create on the job. Know proper procedures to follow when a severe rain or electrical storm strikes.
- Never attempt to operate or work on machinery when not feeling physically fit.
- Never wear loose clothing, rings, watches, heavy gloves etc., that might catch and result in injury.
- Know what safety equipment is required and use it. Such equipment may be: hard hat, safety glasses, reflector type vests, protective gloves and safety footwear.

TERMS & CONDITIONS

CONQUIP ENGINEERING GROUP STANDARD PRODUCT WARRANTY

01. COMMENCEMENT

1.1 This Warranty shall commence on the Commencement Date and shall continue until the earlier of:

- (a) the Expiry Date; or
- (b) the date on which it may be voided in accordance with clause 4.1(b) when it shall terminate automatically without notice.

02. DUTY OF GOOD FAITH

2.1 The Purchaser shall in the exercise of its rights under this Warranty and in the compliance with its obligations under this Warranty be subject to and shall in all respects owe and comply with a duty of good faith to the Warrantor.

03. NATURE AND EXTENT OF COVER

3.1 Subject to clause 3.2 the Warrantor agrees and undertakes to the Purchaser that it shall be liable to the Purchaser under and in accordance with the terms of this Warranty in the event that:

- (a) prior to the Expiry Date the Purchaser shall notify a Warranty Claim to the Warrantor; and
- (b) the Equipment or any relevant part of the Equipment shall have become unusable as the result of defective material or defective workmanship prior to the Expiry Date.

3.2 The Warrantor's obligation under clause 3.1 shall be expressly subject to the provisions of clauses 4, 5 and 6 and conditional upon the Purchaser's compliance in full with the provisions of clause 7.

04. RESTRICTIONS

4.1 The following restrictions apply to this Warranty:

- (a) This Warranty is personal to the Purchaser and neither the legal benefit nor legal burden of this warranty may be assigned or novated or otherwise transferred by the Purchaser to any other party. Any purported assignment, novation or transfer shall not be binding upon the Warrantor.
- (b) This Warranty shall be void in the event that the Purchaser:

- (i) cannot provide authentic and original documentary evidence that the Purchaser has during the period between the Commencement Date and the Expiry Date complied with the Maintenance and Servicing Requirements; and/or
- (ii) has, during the period between the Commencement Date and the Expiry Date, exceeded the Purchaser's Usage Cycle Parameters; and/or
- (iii) has, during the period between the Commencement Date and the Expiry Date, exceeded the Purchaser's Use Parameters; and/or
- (iv) has carried out, or procured the carrying out by any third party of, any repair to the Equipment or any part of the Equipment which is not an Authorised Repair; and/or
- (v) has operated the Equipment after having replaced any part of the Equipment with a part which has not been supplied and fitted by the Warrantor; and/or
- (vi) has modified the Equipment in any way prior to use.

05. EXCLUSIONS

5.1 The following are excluded from the scope of this Warranty:

- (a) Loss of and/ or damage to the Equipment or any part of it resulting from any collision between the Equipment and any other fixed or stationary or mobile object whatsoever, irrespective of whether that collision was or was not caused by the Purchaser; and/or
- (b) Loss of and/or damage to any personal property and/or possessions or other equipment not forming part of the Equipment but which is present in or about the Equipment; and/or
- (c) loss and/or damage which is covered by any other insurance policy taken out and maintained by the Purchaser or in respect of which the Purchaser has a contractual obligation to do so; and/or
- (d) loss and/or damage to the equipment which is consistent with the use by the Purchaser of the Equipment:
 - (i) in compliance with the Maintenance and Servicing Requirements; and
 - (ii) in compliance with the Usage Cycle Parameters; and
 - (iii) in compliance with the Use Parameters; and
 - (iv) having only carried out Authorised Repairs to the Equipment; and
 - (v) having all and any replacement parts fitted by the Warrantor; and
 - (vi) in unmodified form.

06. LIMITATION OF LIABILITY

6.1 The Warrantor's liability to the Purchaser shall be limited as follows:

- (a) The Warrantor shall not in any circumstances be liable to the Purchaser for indirect and/or consequential and/or economic loss suffered and/or incurred as the case may be by the Purchaser; and
- (b) The Warrantor shall only be liable to the Purchaser for the reasonable and proper costs reasonably and properly incurred by the Purchaser directly in connection with the repair and/or replacement (at the Warrantor's absolute discretion) of the Equipment or any part of the Equipment; and
- (c) The Warrantor's liability to the Purchaser shall notwithstanding any other provision of this Warranty, not in any circumstances exceed the Purchase Price of the Equipment.

07. WARRANTY CLAIMS

7.1 The Purchaser shall in respect of any claim against the Warrantor under this Warranty and within 24 hours of the occurrence of the subject matter of the Warranty Claim:

- (a) Complete in full and submit to the Warrantor a Warranty Claim in the form annexed to Schedule 4;
- (b) Provide date stamped or date identifiable photographs evidencing the claim; and
- (c) Make the Equipment or the relevant part of the Equipment available to the Warrantor for inspection within 48 hours of notification of the relevant Warranty Claim.

08. ENTIRE AGREEMENT

8.1 This Warranty constitutes the entire agreement between the parties and supersedes and extinguishes all previous promises, assurances, warranties, representations and understandings between them, whether written or oral, relating to its subject matter.

8.2 Each party agrees that it shall have no remedies in respect of any statement, representation, assurance or warranty (whether made innocently or negligently) that is not set out in this Warranty. Each party agrees that it shall have no claim for innocent or negligent misrepresentation or negligent misstatement based on any statement in this Warranty.

No variation of this Warranty shall be effective unless it is in writing and signed by the parties (or their authorised representatives).

09. WAIVER

No failure or delay by a party to exercise any right or remedy provided under this Warranty or by law shall constitute a waiver of that or any other right or remedy, nor shall it prevent or restrict the further exercise of that or any other right or remedy. No single or partial exercise of such right or remedy shall prevent or restrict the further exercise of that or any other right or remedy.

10. SEVERANCE

10.1 If any provision or part-provision of this Warranty is or becomes invalid, illegal or unenforceable, it shall be deemed deleted, but that shall not affect the validity and enforceability of the rest of this Warranty.

10.2 If any provision or part-provision of this Warranty is deemed deleted under clause 10.1 the parties shall negotiate in good faith to agree a replacement provision that, to the greatest extent possible, achieves the intended commercial result of the original provision.

11. THIRD PARTY RIGHTS

11.1 This Warranty does not give rise to any rights under the Contracts (Rights of Third Parties) Act 1999 to enforce any term of this Warranty.

12. GOVERNING LAW

12.1 This Warranty and any dispute or claim (including non-contractual disputes or claims) arising out of or in connection with it or its subject matter or formation shall be governed by and construed in accordance with the law of England and Wales.

13. JURISDICTION

13.1 Each party irrevocably agrees that the courts of England and Wales shall have exclusive jurisdiction to settle any dispute or claim (including non-contractual disputes or claims) arising out of or in connection with this Warranty or its subject matter or formation.

EC DECLARATION OF CONFORMITY

IN ACCORDANCE WITH EN ISO 17050-1:2004

Declaration: As defined by the Machinery Directive 2006/42/EC and subsequent amendments

We, CONQUIP ENGINEERING GROUP, herewith declare that the following indicated equipment meets the fundamental health and safety requirements concerning the EU guideline(s), due to their design and manufacture.

This declaration will be rendered null and void if the machine is changed without our approval.

SIGNED:

DATED: 2024

Garry Critchley, Chief Executive Officer

PRODUCT CODES	GENERAL DESCRIPTION / DESIGNATION	WORKING LOAD LIMIT
SS905-17389	Safety Briefing Station	Self-weight

ITEM	CODE	DESCRIPTION
EC DIRECTIVE/REGULATION	2006/42/EC	Directive 2006/42/EC- new machinery directive
HARMONISED STANDARDS	BS EN ISO 12100:2010	Safety of machinery General principles for design Risk assessment and risk reduction
OTHER REGULATIONS	LOLER 1998	Lifting Operations and Lifting Equipment Regulations 1998 (LOLER)
	PUWER 1998	Provision and Use of Work Equipment Regulations 1998 (PUWER)

TALKING TO US IS EASY
WE'RE HERE TO HELP

Call us on 0333 300 3470
Email us at sales@cqegroup.com
www.cqegroup.com

