

USER GUIDE

# SMART-RELEASE BULKX

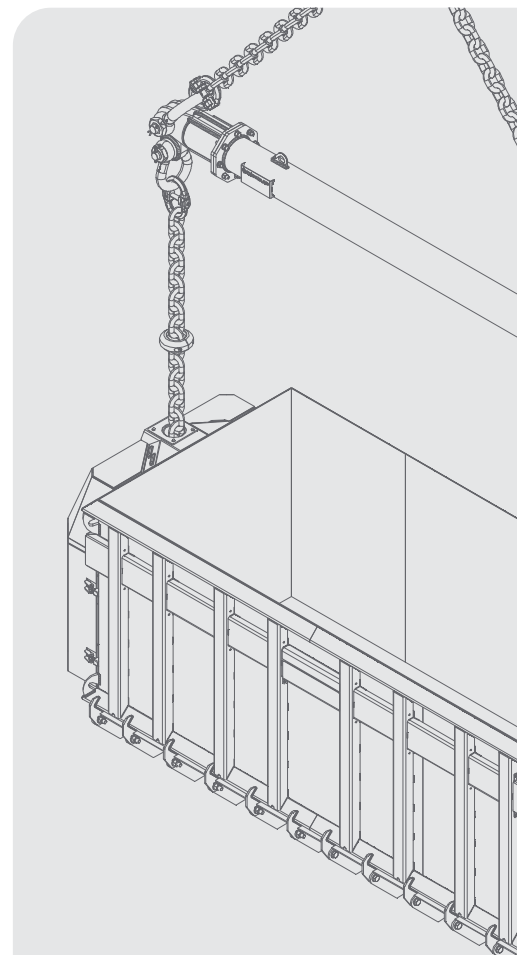

# DISCLAIMER

Do not attempt to handle or operate this equipment before you have received sufficient training. Before use, operatives must have carried out all checks featured on the Visual Inspection Sheet on page 29. It is imperative that you have read the General Safety Instructions set out on pages 30-31 and sufficiently familiarised yourself with the Operational Procedures in this document.

Note that this item is compliant only to the standards specified in this User Guide and it is therefore the duty of the responsible person(s) to review and ensure compliance.

# CONTENTS

## PRODUCT INFORMATION

INTRODUCTION	04
SPECIFICATION	06

## USAGE

GETTING SET UP	12
PREOPERATION TEST CYCLE	16
OPERATIONAL USE	19
AFTER OPERATIONAL USE	23
BATTERY & REMOTE CONTROL	24

## MAINTENANCE & INSPECTION

MAINTENANCE REGIME	28
VISUAL INSPECTION CHECKLIST	29

## SAFETY

SAFETY INSTRUCTIONS	30
---------------------	----

## LEGAL

TERMS AND CONDITIONS	34
EC DECLARATION OF CONFORMITY	40
STANDARDS AND REGULATIONS APPLICABLE	41

# INTRODUCTION

## OVERVIEW

With decades of experience in the design, manufacture, and support of construction equipment throughout the UK and EU, and built on the same DNA as our standard BulkX Range, the Smart-Release BulkX sets the standard for safety, efficiency, and adaptability, in the transportation of earth (muck) from an excavation zone.

Constructed on a modular architecture, the Smart-Release BulkX development is formed around the ethos of “reliability through durability” with the ultimate objective of maximising our customers’ and partners’ uptime and productivity, while reducing their costs.

Unlike our standard BulkX range where a static gantry was a prerequisite, the new Smart-Release BulkX utilises a cableless control system to remotely discharge the skip in a preassigned location on-site. Offered in several sizes, ranging from 6,000 litres (14,000Kg WLL) to 14,000 litres (28,000Kg WLL), the new Smart-Release BulkX range compliments the majority of site-specific requirements.



## KEY BENEFITS

- **ZERO EMISSION, ZERO MAINTENANCE POWER**  
Powered by a 58Ah Lithium-ion battery with inbuilt active cooling that provides 8 hours of operational time/60 cycles (whichever occurs first) on a single charge without requiring an external battery management system.
- **FLEXIBLE CHARGING**  
The Smart-Release BulkX is supplied with an external charger allowing the battery to be charged from 20% to 100% in as little as 6 hours from any location. The charger’s enclosure protects against vibration, shock, dirt, chemicals and fluids, using charge algorithms to balance charge time against battery life.
- **FULLY ELECTRIC**  
The system of actuator, control, and power connection for the patented integrated positioning locking mechanism, unlike similar hydraulic systems, is maintenance-free, with the capability to be always operational, has low energy consumption and cannot result in fluid leaks.
- **REMOTE OPERATED**  
The Smart-Release BulkX can be discharged from a multitude of locations and can be controlled via an ergonomic and robust safety radio remote control with a backlit display informing the operator of the most critical information, including the status of the locking mechanism and the charge percentage of both the battery and remote.
- **SPECIAL WARNING BEACONS**  
The Smart-Release BulkX is equipped with twelve beacons (six on either side) to provide maximum visibility coverage to the site’s personnel. These beacons allow all those within sight to know if the system is live (green beacon) and/or under active command (amber beacons).
- **SAFETY**  
To reduce the chances of an accidental discharge, the patented locking mechanism is geometrically restricted to mitigate inadvertent actuation, unauthorised operation, and unintended commands while the Smart-Release BulkX is locked and lifted above ground. Combining this with the active status feedback from the remote and the special warning beacons, the Smart-Release BulkX has proven to be the safer option for operators and site personnel.
- **MINIMAL MAINTENANCE**  
Maximises your uptime and reduce maintenance requirements as a result of the fully electric system.
- **UKAS ACCREDITED**  
IP65 Tested design.

**ENGINEERED, DEVELOPED, MANUFACTURED AND TESTED IN ENGLAND**

# SPECIFICATION

## THE RANGE

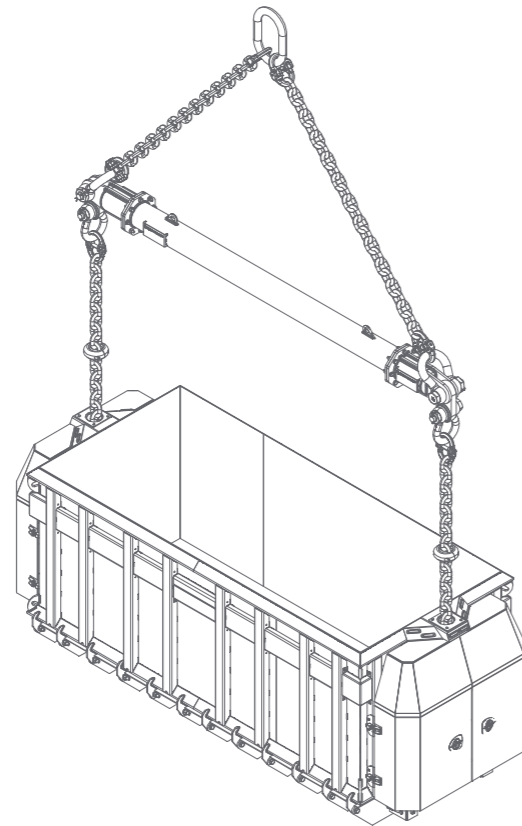

CODE	CAPACITY (litres)	WLL* (kg)	WEIGHT (kg)
CA530-04000	4000	10000	2300
CA530-05000	5000	10000	2500
CA530-06000	6000	14000	3000
CA530-07000	7000	14000	3250
CA530-08000	8000	20000	3860
CA530-010000	10000	20000	4100
CA530-012000	12000	28000	4900
CA530-014000	14000	28000	5150
CA530-016000	16000	32000	5400

\*Working Load Limit

# SPECIFICATION

## STANDARD

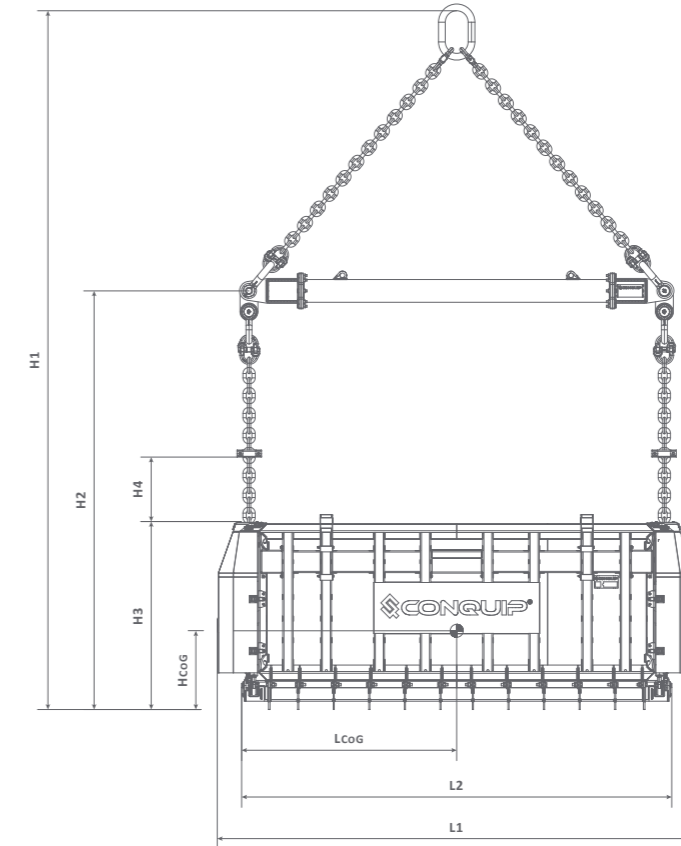

CODE	H1	H2	H3	H4	HCoG*	LCoG	L1	L2
CA530-04000	5170	3455	1560	470	1000 (695)	1320	3110	2640
CA530-06000	6750	3595	1785	345	1090 (825)	1567	3610	3135
CA530-08000	6640	4050	1810	620	1350 (805)	2070	4610	4140
CA530-010000	6640	4050	1810	620	1400 (955)	2070	4610	4140
CA530-012000	7280	4110	1960	560	1420 (820)	2570	5610	5140
CA530-014000	7280	4110	1960	560	1450 (935)	2570	5610	5140
CA530-016000	7965	4680	2490	560	1680 (1030)	2570	5590	5140

All dimensions are measured in mm.  
\*Figures in brackets refer to Skip only.

# SPECIFICATION

## STANDARD

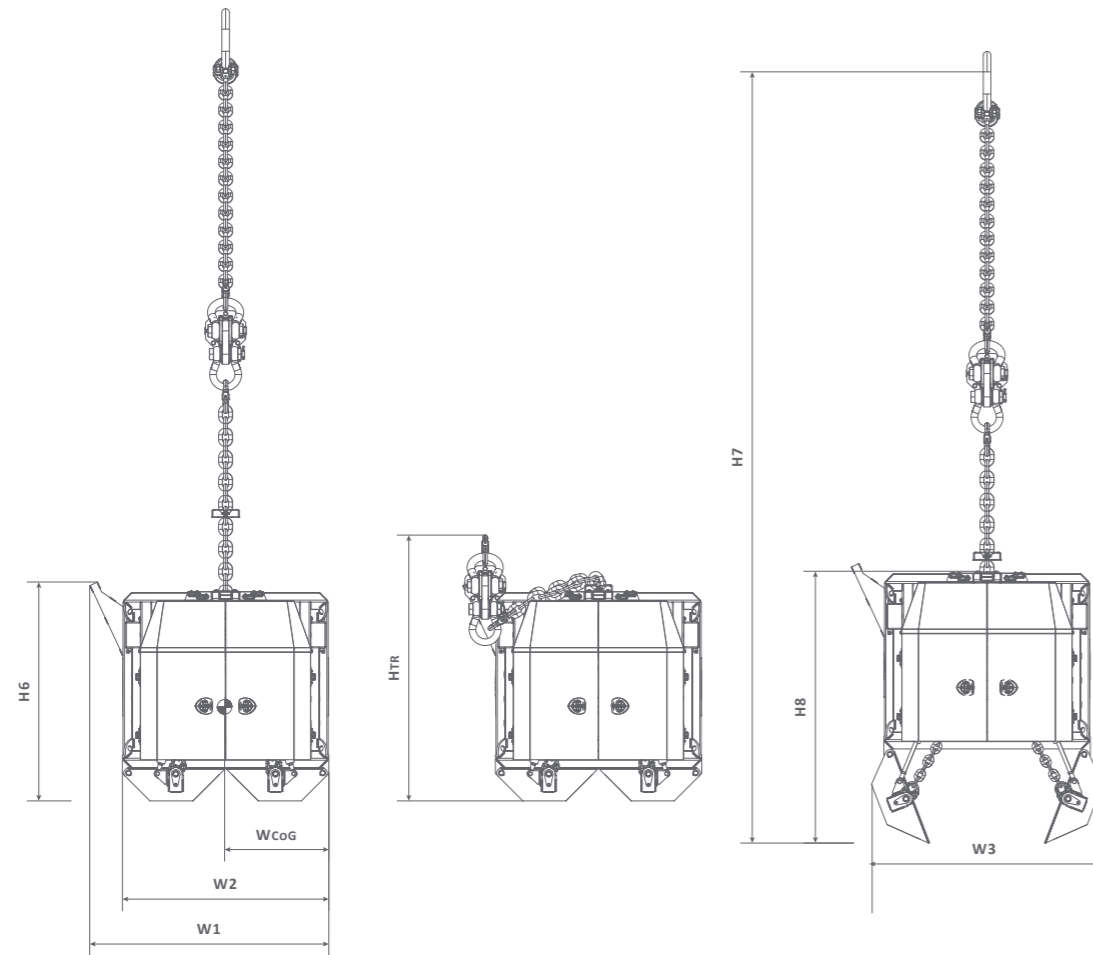

CODE	H6	H7	H8	HTR	WCoG	W1	W2	W3
CA530-04000	1650	5230	2245	1685	885	2050	1770	1920
CA530-05000	1650	5230	2245	1765	885	2050	1770	1920
CA530-06000	2385	5695	2325	1905	885	2050	1770	1980
CA530-07000	2385	5695	2325	1990	885	2050	1770	1980
CA530-08000	1880	6600	2330	2270	885	2050	1770	1980
CA530-010000	2180	6600	2330	2570	885	2150	1770	1980
CA530-012000	2040	7330	2475	2420	885	2050	1770	1980
CA530-014000	2340	7330	2475	2720	885	2150	1770	1980
CA530-016000	2490	7965	3010	2490	885	2150	1770	1980

All dimensions are measured in mm.

# SPECIFICATION

## WITH GREEDY BOARD

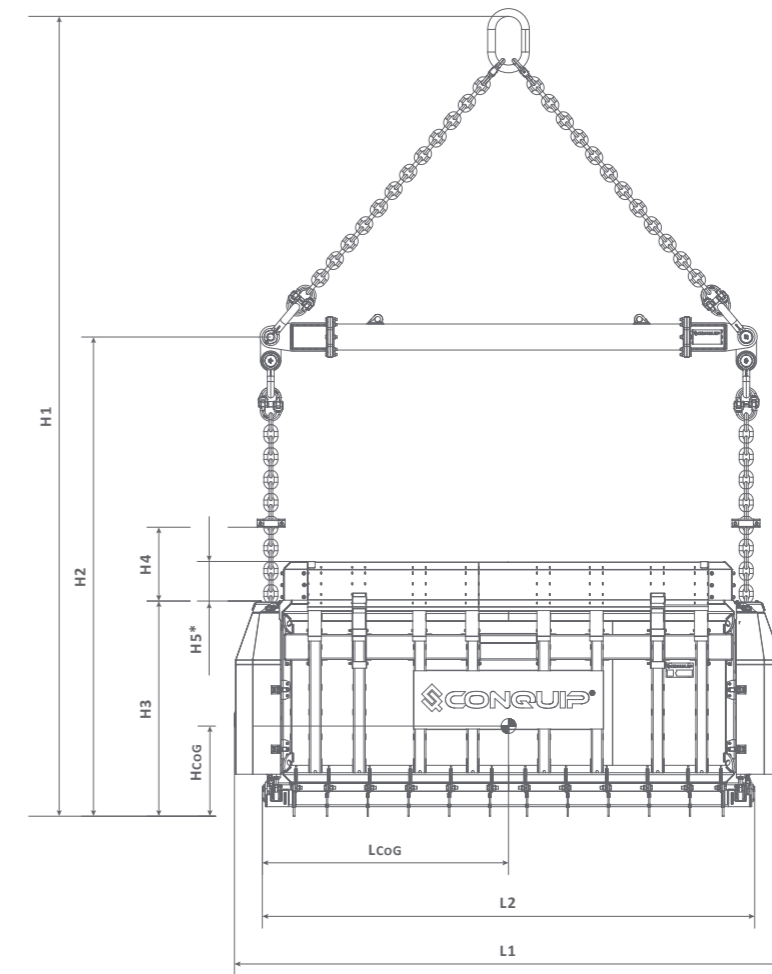

CODE	H1	H2	H3	H4	H5*	HCoG**	LCoG	L1	L2
CA530-05000	5170	3455	1560	470	190	1045 (805)	1320	3110	2640
CA530-07000	6750	3595	1785	345	185	1135 (890)	1567	3610	3135
CA530-010000	6640	4050	1810	620	330	1400 (955)	2070	4610	4140
CA530-014000	7280	4110	1960	560	330	1450 (935)	2570	5610	5140

All dimensions are measured in mm.  
 \* Only applicable to 5,000, 7,000, 10,000 and 14,000 litre models.  
 \*\*Figures in brackets refer to Skip only.

# ALWAYS UP FOR THE CHALLENGE

Our team of Application Engineers love working on big projects like this range of remote operated bulk excavation skips.

We strive to develop solutions that improve safety and productivity on-site, while providing next-level customer support.



# OPERATIONAL PROCEDURES: GETTING SET UP

## DOCUMENTATION

01. Prior to the delivery of the Smart-Release BulkX, Conquip Engineering Group advises that, at the minimum, the documentation/procedures below are in place:

ITEM NUMBER	ITEM DESCRIPTION	YES/NO	SIGNATURE
01	Are all the responsible operators and support staff trained to use the Smart-Release BulkX?		
02	Are there LOLER and PUWER qualified staff on site to inspect the Smart-Release BulkX upon delivery and throughout its use?		
03	Have the relevant Lift Plan documentation and procedures been approved?		
04	Have the relevant Risk Assessment documentation and procedures been approved?		
05	Have the relevant Health and Safety documentation and procedures been approved?		
06	Are you in possession of all the required certificates and/or documentation for the Smart-Release BulkX?		

**PLEASE NOTE:**

The above procedures may not suffice for your site and/or application, it is the duty of the responsible personnel on-site to determine their requirements. If in doubt, contact our customer service team who may be able to advise on how best to proceed.

## DELIVERY

01. The Smart-Release BulkX is delivered to site by Conquip Engineering Group or one of our trusted partners.
02. The site's responsible personnel unload the Smart-Release BulkX utilising their preapproved procedures (e.g. Lift Plan, Risk Assessment etc).
03. Once the Smart-Release BulkX has been safely placed and the spreader beam assembly secured onto the hooks, the responsible personnel can proceed with the visual inspection.



## VISUAL INSPECTION

04. Open the doors on either end of the Smart-Release BulkX and carry out a full visual examination. The Smart-Release BulkX shall exhibit no signs of material distress, deformation, local buckling, weld failure or cracking at any location. You may refer to the Visual Inspection Checklist on page 29.

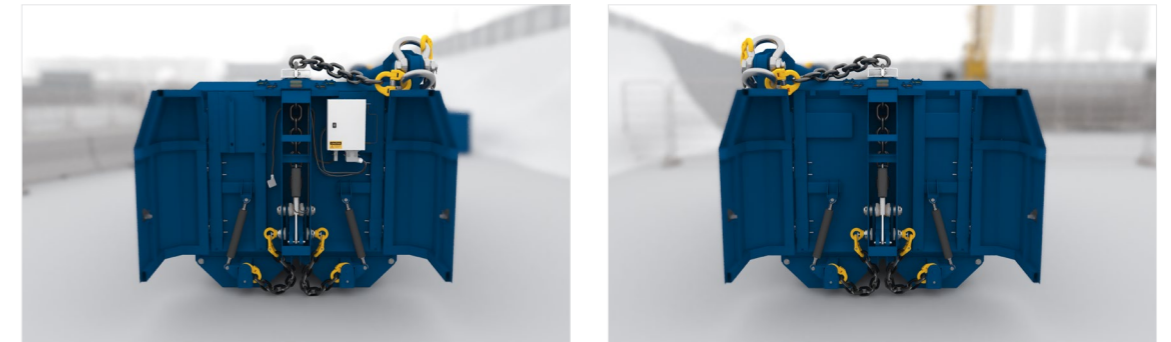

ITEM	YES/NO	SIGNATURE
Battery Box		
Battery Charging Unit		
Remote Control		
Remote Control Charger		
NS Series Key		

05. Open the accompanying hardshell case and ensure you have the items below:



### BATTERY INSTALLATION

01. Remove the battery box from the hardshell case and inspect it ensuring there are no signs of damage, paying special attention to the connector(s).
02. Carry the battery box to the Smart-Release BulkX and install it onto the brackets provided.
03. Attach the Harting connectors securely.



### POWERING ON

01. Carry out a full visual inspection of the electrical wiring and components. The electrical components and wiring should exhibit no signs of damage or fraying.
02. Ensure all connectors are installed and secured correctly as they may have loosened during transport.
03. To turn on the battery, press the button on the side of the battery box once. A red light will illuminate to indicate the battery has been turned on.
04. Adjust the receiver's antenna location, positioning it on a secure surface of the skip. Conquip Engineering Group advises the position below as it will provide the required protection from small debris.



05. On the remote, press and hold the ON/START button until the CONQUIP logo has appeared followed by the "LOCKED" screen. All six green beacons will now have turned ON and should remain on continuously until you have turned OFF/STOPPED the remote.



06. Close the doors securely.





### PREOPERATION TEST CYCLE

01. Before operations can begin, Conquip Engineering Group advises that at least one test cycle is completed prior to any earth (muck) being loaded into the Smart-Release BulkX to confirm the system is nominal.
02. Complete a full inspection compliant to LOLER and PUWER regulations.
03. Connect the master link on the spreader beam onto the crane hook and slowly lift the Smart-Release BulkX approximately one metre above the ground.



04. Commence with a visual inspection specifically examining the Smart-Release BulkX gate hinges for damage and for any twists in the chains.
05. Lower the Smart-Release BulkX onto the ground until the white chain stops are fully resting on the skip and the chains are slack (not carrying load).



06. Press the UNLOCK button on the remote. The remote should read DISENGAGING and the amber beacons should start flashing.
07. Wait until the remote reads UNLOCKED (this could take approximately 10 seconds).

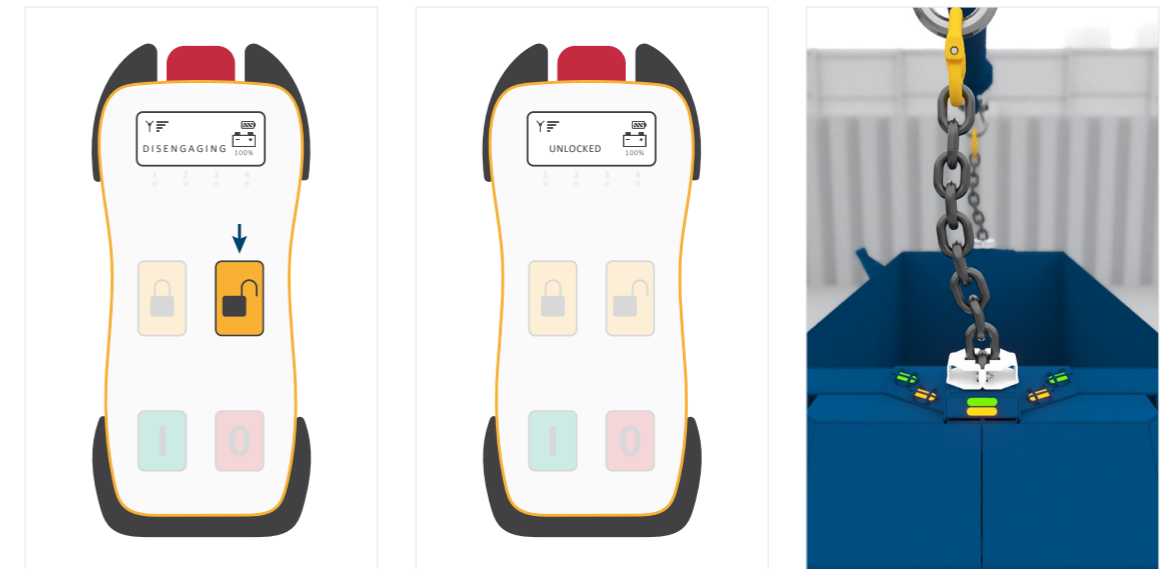

08. Slowly lift the skip until the gates are opened fully.



09. Once the Smart-Release BulkX has settled, carry out another visual inspection specifically examining the gate mechanism to ensure it is not being jammed or interrupted through its arc.

- Press the LOCKED button on the remote, while the Smart-Release BulkX is still being held in the air, until the gates have closed fully and the amber beacons have turned off (this could take approximately 10 seconds).

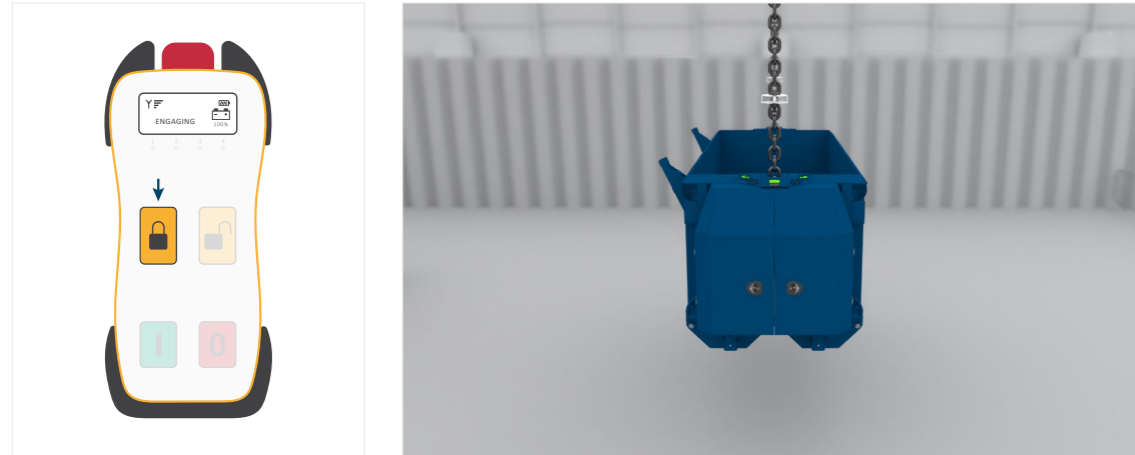

- Lower the skip back onto the ground and secure it.
- Commence with a visual inspection to ensure there has been no damage throughout the test process.
- Press and hold the OFF/STOPPED button on the remote until both the remote and the green beacons have turned off.



- Open the door on the Smart-Release BulkX and press and hold the power button on the battery box until the red light has turned off.
- Close the doors securely.
- The test cycle is now complete.

## OPERATIONAL USE

- Conquip Engineering Group advises that prior to the start of each shift at least one test cycle is completed.
- Ensure the battery and remote are fully charged.
- To turn on the battery, press the button on the side of the battery box once. A red light will illuminate to indicate the battery has been turned on.



- On the remote, press and hold the ON/START button until the CONQUIP logo has appeared followed by the "LOCKED" screen. All six green beacons will now have turned ON and should remain on continuously until you have turned OFF/STOPPED the remote.



- 05. Connect the master link on the spreader beam onto the crane hook and slowly lift the Smart-Release BulkX to the excavation location.
- 06. Fill the Smart-Release BulkX with earth(muck) and ensure it is distributed evenly throughout the skip.

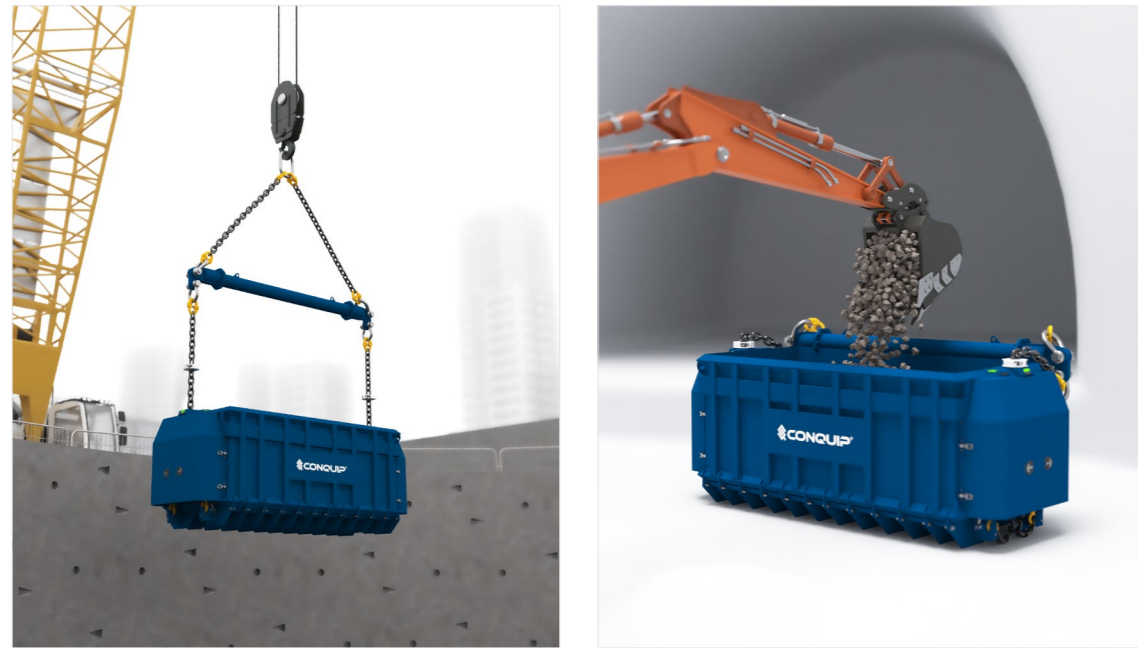

- 07. Review the remote to ensure it still reads "LOCKED" and that only the green beacons are on.



- 08. Slowly lift the loaded Smart-Release BulkX to the discharge location and lower it onto a flat surface.
- 09. Lower the Smart-Release BulkX onto the ground until the white chain stops are fully resting on the skip and the chains are slack (not carrying load).
- 10. Press the UNLOCK button on the remote. The remote should read DISENGAGING and the amber beacons should start flashing.

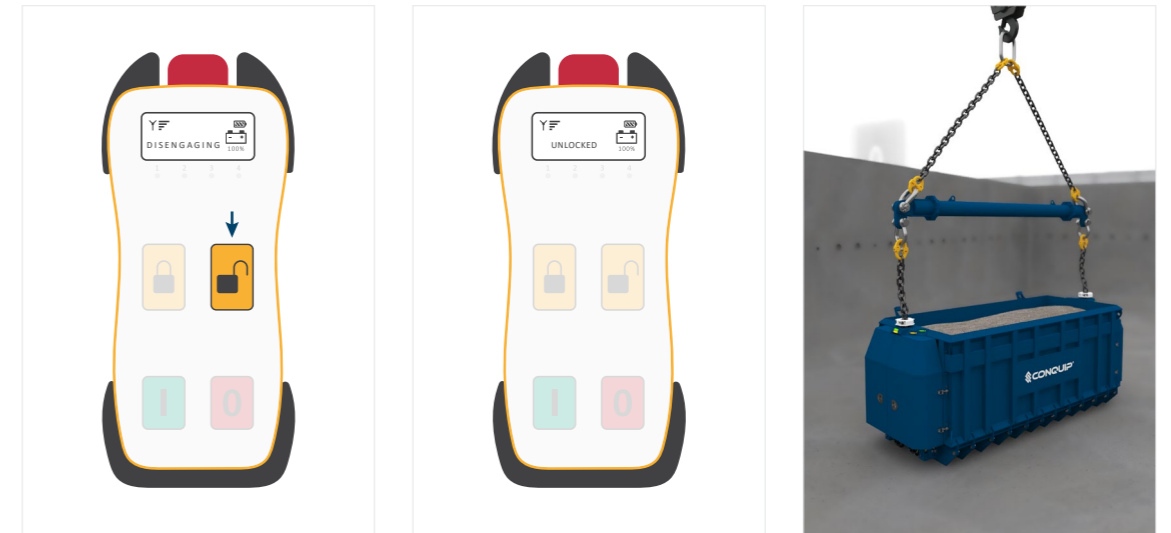

- 11. Wait until the remote reads UNLOCKED (this could take approximately 10 seconds).



12. Slowly lift the skip until the gates are opened fully and the earth (muck) is discharged completely.
13. Once the Smart-Release BulkX has settled, press the LOCKED button on the remote, while the Smart-Release BulkX is still being held in the air, until the gates have closed fully and the amber beacons have turned off (this could take approximately 10 seconds).



14. Return to the excavation site and repeat.

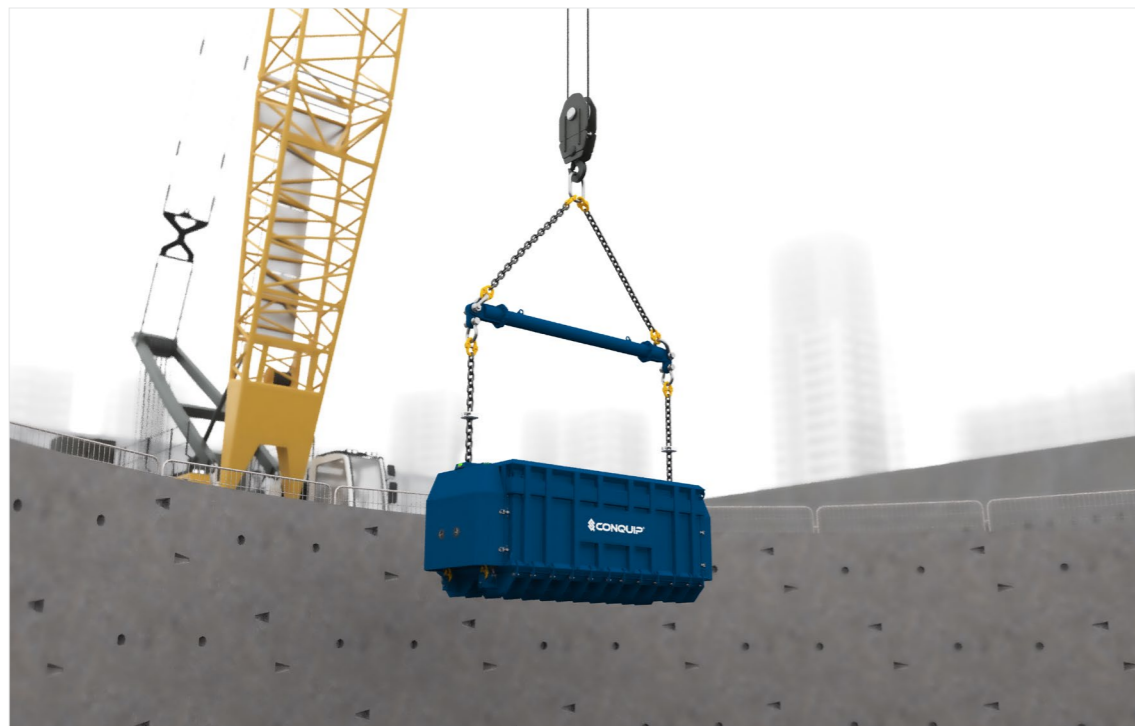

### AFTER OPERATIONAL USE

01. Lift the Smart-Release BulkX to the storage location and secure it.



02. Ensure the Smart-Release BulkX remote and battery are turned off.



03. Conquip Engineering Group advises that the battery box is removed from the Smart-Release BulkX and either stored in the hardshell case or charged if necessary.



04. Conquip Engineering Group advises that the remote control is either stored in the hardshell case or charged if necessary.

### HOW TO CHARGE THE BATTERY

01. Ensure that the battery is powered off by pressing the button located on the left-hand side of the enclosure. This will cause the indicator light on the front of the enclosure to turn off.
02. Disconnect the power connector and remove the battery box from the skip.
03. In a suitable location, dry and protected from the elements, plug the charger's power cord into a standard socket and turn it on using the on/off switch.
04. Connect the charger's charging cable to the battery and activate the charging process by pressing the battery's on/off button to the 'on' position. This will cause the red indicator light on the front of the battery enclosure to illuminate, indicating that charging has commenced.
05. The charging process is complete when the indicator light on the charger changes from flashing green to solid green, indicating that the battery has reached its full charge.

### CONTROLS AND OPERATING

#### Remote Control

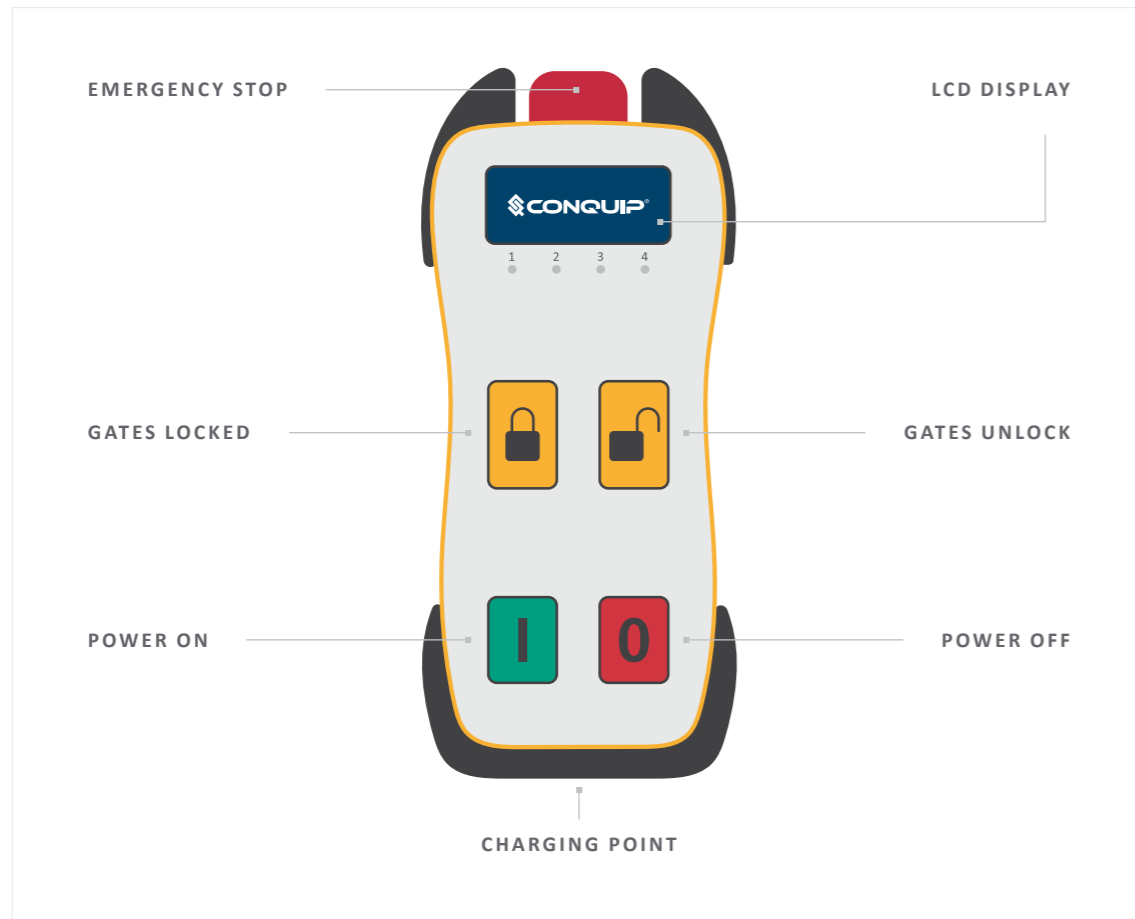

### Display Information

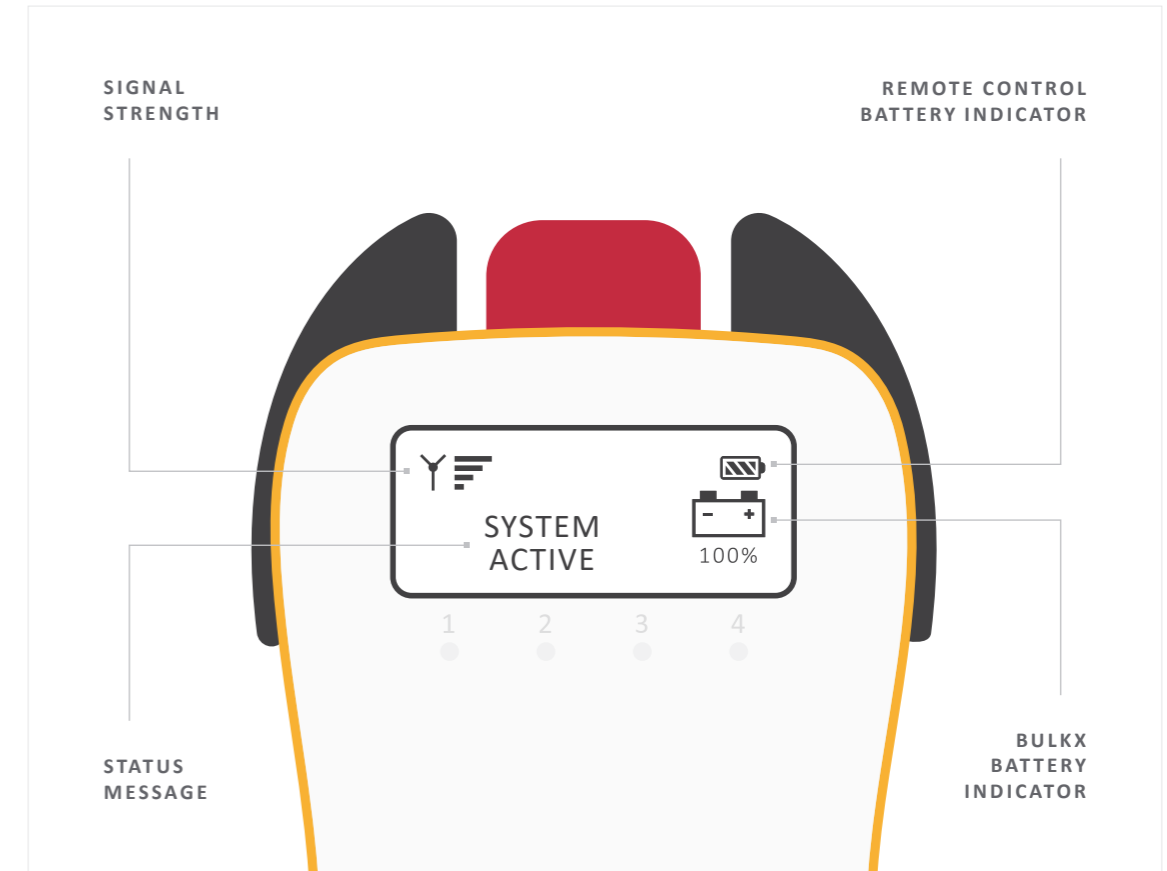

# GENERAL INFORMATION ON USING REMOTE CONTROLS

## DETERMINING THE RANGE

There are four factors that determine the range of your remote control:

01. Power of the transmitter.
02. Sensitivity of the receiver.
03. The antenna gain factor.
04. Weakening of the radio signal.

Below are some tips on how to enhance the range of your remote control:

## AVOID DAMPING

The type of material determines how the radio waves are affected. Damping can vary greatly depending on the material.

For example, plastic housing or control boxes have a very limited impact on any signals so the antenna can even be mounted inside the cabinet.

However, a reinforced concrete wall, 20cm thick, does not transmit any Radio Frequency (RF) signals. The most challenging obstacle for radio signals is metal as it reflects them and does not let any through.

## CONSIDER REFLECTIONS

The signal from the transmitter is reflected from the ground and to the antenna. The signal also reflects through the facades between buildings. The signal can reach the receiver through reflections on surrounding structures, even if there is a building or steel wall between them.

## FACTORS THAT INFLUENCE RADIO WAVES

Environmental variables can negatively affect the strength of the signal and range of RF systems including: walls, trees, hills, fences, humidity, rain/snow, electric fields, or other RF systems.

## HOW TO GET THE BEST RESULTS FROM YOUR REMOTE CONTROL

- Ensure a clear line of sight between the remote and the device you want to control.
- Remove any physical obstructions that may hinder the signal, where possible.
- Replace the batteries in your remote control regularly, as weak batteries can limit the range.
- Avoid interference from other electronic devices, as they can disrupt the signal.

# MAINTENANCE & INSPECTION

## MAINTENANCE REGIME

- It is mandatory that the equipment is thoroughly examined regularly, by a qualified engineer, to ensure compliance with relevant regulations. Conquip recommend to carry out a thorough examination every six months.
- This product may incorporate various loose and detachable items of lifting gear. Refer to the separate requirements for the safe use of those items.
- When not being used, store the unit in a clean, upright condition and in a safe place where it will be protected from thieves and unauthorised users.
- This equipment must be inspected by the responsible person before each use and then regularly, as determined by your risk assessment or working practice. If you have any concerns about the skip's condition or suitability, do not use it.

## SAFETY DECALS:

These are the safety decals featured on the Smart-Release BulkX Skip. When carrying out the visual inspection of the skip, please ensure all decals are present before checking this item off the list.



## VISUAL INSPECTION CHECKLIST

INSPECTION ITEMS	RESULTS		COMMENTS
	SATISFACTORY	UNSATISFACTORY	
Serial Number			CQ.....
Product Code			
Working Load Limit (Kg)			
Tare Mass (Kg)			
Conforms to user guide specification			
Lifting slings			
Lifting attachments			
Skip body			
Gate body			
Gate hinges			
Spreader beam body			
Door body			
Door hinges			
Additional steel components			
Electrical components			
Electrical wiring			
Dampeners			
Screws, bolts, washers, nuts...etc.			
Surface finish			
Safety decals			
Notices			
Logbook			
General condition			
<b>SIGNATURE</b>			
Name	Position	Qualification	Signature & Date

# GENERAL SAFETY INSTRUCTIONS

The Smart-Release BulkX should be properly operated and maintained to keep it in a safe, efficient operating condition. Be sure that all controls are free of mud, grease, or other matter that might cause slips hazardous to the operator, serviceman, or other personnel or equipment. Report all malfunctions to those responsible for maintenance, and do not operate the equipment until corrected. Normal service or maintenance performed as required can prevent unexpected and unnecessary downtime.

This operations manual describes general inspections, servicing and operation with the normal safety precautions required for normal servicing and operating conditions. It is not a guide however, for other than normal conditions or situations, and therefore, servicemen and operators must be safety conscious and alert to recognise potential servicing or operating safety hazards at all times, and take necessary precautions to assure safe servicing and operation of the machine.



**M002**  
Refer to instructions manual/booklet



**M004**  
Wear eye protection



**M008**  
Wear safety footwear



**M009**  
Wear protective gloves



**M010**  
Wear protective clothing



**M014**  
Wear head protection



**M015**  
Wear high-visibility clothing



**P012**  
No heavy load

## GENERAL NOTES:

- Read this operations manual and learn the operating characteristics and limitations of the Smart-Release BulkX. Know what operating clearances the machine requires.
- Read and understand all the safety signs prior to operation.
- If the safety signs are obstructed by dirt or debris, clean them using mild soap and water prior to operation.
- Be aware of operating hazards that weather changes can create on the job. Know proper procedures to follow when a severe rain or electrical storm strikes.
- Never attempt to operate or work on a Smart-Release BulkX when not feeling physically fit.
- Know what safety equipment is required and use it. Such equipment may be: hard hat, safety glasses, reflector type vests, respirators, and ear plugs.
- Never wear loose clothing, rings, watches, heavy gloves etc., that might catch levers and controls and cause loss of control.
- Keep hands and controls free from water, grease, and mud to assure nonslip control.
- If the safety signs are damaged or illegible, replace them immediately, prior to operation.



## GENERAL FIRE PRECAUTIONS

- Make sure the site has a fire extinguisher and that it is accessible and fully charged. (Not furnished with the Smart-Release BulkX.)

## ELECTRICAL HAZARD PRECAUTIONS

- Never smoke or allow open flames or sparks near batteries.
- Leave the battery box uncovered when charging batteries for adequate ventilation.
- Always disconnect batteries before repairing the electrical system to avoid danger of fire-causing sparks. Disconnect the battery first and reconnect last.
- Always disconnect batteries before conducting any welding on the machine.
- Never check the battery charge by placing metal objects across the battery posts, for the avoidance of sparks at the battery posts.

## SMART-RELEASE BULKX BATTERY & CHARGER PRECAUTIONS

- Only use the provided charger and batteries for the Smart-Release BulkX.
- Inspect prior to use to ensure both battery and charger are free from damage.
- Do not expose the battery or charger to extreme temperatures or moisture.
- No charging should take place if ambient temperatures are below 0 degrees centigrade or higher than 45 degrees centigrade.
- Do not attempt to open or tamper with the battery or charger.
- For charging, the AC supply must be capable of 100-240V, 50/60Hz, 1140W.

## IN CASE OF TROUBLE

If trouble develops on site, move the Smart-Release BulkX off the site at the first safe instance, and shut off the power. Carefully note as many of the symptoms of the trouble as possible, such as rough actuator operation with loss of power and overheating, or loss of speed, etc.

If the area of the site in which the trouble occurs requires that the Smart-Release BulkX be left unattended while the trouble is reported by phone, disconnect the battery, and apply security locks, if so equipped, before leaving the Smart-Release BulkX. Make sure that the Smart-Release BulkX is disconnected from the crane.

Report the following data as soon as possible.

01. Exact location.
02. Destination.
03. The nature of the trouble (with as many details as possible) and the time and conditions under which it happened.
04. The telephone number at which the Smart-Release BulkX operator can be reached.

### NOTICE:

Do not attempt to restart or operate the Smart-Release BulkX unless instructed to do so.

# TERMS & CONDITIONS

## CONQUIP ENGINEERING GROUP STANDARD PRODUCT WARRANTY

### 01. COMMENCEMENT

1.1 This Warranty shall commence on the Commencement Date and shall continue until the earlier of:

- (a) the Expiry Date; or
- (b) the date on which it may be voided in accordance with clause 4.1(b)

when it shall terminate automatically without notice.

### 02. DUTY OF GOOD FAITH

2.1 The Purchaser shall in the exercise of its rights under this Warranty and in the compliance with its obligations under this Warranty be subject to and shall in all respects owe and comply with a duty of good faith to the Warrantor.

### 03. NATURE AND EXTENT OF COVER

3.1 Subject to clause 3.2 the Warrantor agrees and undertakes to the Purchaser that it shall be liable to the Purchaser under and in accordance with the terms of this Warranty in the event that:

- (a) prior to the Expiry Date the Purchaser shall notify a Warranty Claim to the Warrantor; and
- (b) the Equipment or any relevant part of the Equipment shall have become unusable as the result of defective material or defective workmanship prior to the Expiry Date.

3.2 The Warrantor's obligation under clause 3.1 shall be expressly subject to the provisions of clauses 4, 5 and 6 and conditional upon the Purchaser's compliance in full with the provisions of clause 7.

### 04. RESTRICTIONS

4.1 The following restrictions apply to this Warranty:

- (a) This Warranty is personal to the Purchaser and neither the legal benefit nor legal burden of this warranty may be assigned or novated or otherwise transferred by the

Purchaser to any other party. Any purported assignment, novation or transfer shall not be binding upon the Warrantor.

(b) This Warranty shall be void in the event that the Purchaser:

- (i) cannot provide authentic and original documentary evidence that the Purchaser has during the period between the Commencement Date and the Expiry Date complied with the Maintenance and Servicing Requirements; and/or
- (ii) has, during the period between the Commencement Date and the Expiry Date, exceeded the Purchaser's Usage Cycle Parameters; and/or
- (iii) has, during the period between the Commencement Date and the Expiry Date, exceeded the Purchaser's Use Parameters; and/or
- (iv) has carried out, or procured the carrying out by any third party of, any repair to the Equipment or any part of the Equipment which is not an Authorised Repair; and/or
- (v) has operated the Equipment after having replaced any part of the Equipment with a part which has not been supplied and fitted by the Warrantor; and/or
- (vi) has modified the Equipment in any way prior to use.

### 05. EXCLUSIONS

5.1 The following are excluded from the scope of this Warranty:

- (a) Loss of and/ or damage to the Equipment or any part of it resulting from any collision between the Equipment and any other fixed or stationary or mobile object whatsoever, irrespective of whether that collision was or was not caused by the Purchaser; and/or
- (b) Loss of and/or damage to any personal property and/or possessions or other equipment not forming part of the Equipment but which is present in or about the Equipment; and/or
- (c) loss and/or damage which is covered by any other insurance policy taken out and maintained by the Purchaser or in respect of which the Purchaser has a contractual obligation to do so; and/or
- (d) loss and/or damage to the equipment which is consistent with the use by the Purchaser of the Equipment:
  - (i) in compliance with the Maintenance and Servicing Requirements; and
  - (ii) in compliance with the Usage Cycle Parameters; and
  - (iii) in compliance with the Use Parameters; and
  - (iv) having only carried out Authorised Repairs to the Equipment; and
  - (v) having all and any replacement parts fitted by the Warrantor; and

(vi) in unmodified form.

## 06. LIMITATION OF LIABILITY

6.1 The Warrantor's liability to the Purchaser shall be limited as follows:

- (a) The Warrantor shall not in any circumstances be liable to the Purchaser for indirect and/or consequential and/or economic loss suffered and/or incurred as the case may be by the Purchaser; and
- (b) The Warrantor shall only be liable to the Purchaser for the reasonable and proper costs reasonably and properly incurred by the Purchaser directly in connection with the repair and/or replacement (at the Warrantor's absolute discretion) of the Equipment or any part of the Equipment; and
- (c) The Warrantor's liability to the Purchaser shall notwithstanding any other provision of this Warranty, not in any circumstances exceed the Purchase Price of the Equipment.

## 07. WARRANTY CLAIMS

7.1 The Purchaser shall in respect of any claim against the Warrantor under this Warranty and within 24 hours of the occurrence of the subject matter of the Warranty Claim:

- (a) Complete in full and submit to the Warrantor a Warranty Claim in the form annexed to Schedule 4;
- (b) Provide date stamped or date identifiable photographs evidencing the claim; and
- (c) Make the Equipment or the relevant part of the Equipment available to the Warrantor for inspection within 48 hours of notification of the relevant Warranty Claim.

## 08. ENTIRE AGREEMENT

8.1 This Warranty constitutes the entire agreement between the parties and supersedes and extinguishes all previous promises, assurances, warranties, representations and understandings between them, whether written or oral, relating to its subject matter.

8.2 Each party agrees that it shall have no remedies in respect of any statement, representation, assurance or warranty (whether made innocently or negligently) that is not set out in this Warranty. Each party agrees that it shall have no claim for innocent or negligent misrepresentation or negligent misstatement based on any statement in this Warranty.

No variation of this Warranty shall be effective unless it is in writing and signed by the parties (or their authorised representatives).

## 09. WAIVER

No failure or delay by a party to exercise any right or remedy provided under this Warranty or by law shall constitute a waiver of that or any other right or remedy, nor shall it prevent or restrict the further exercise of that or any other right or remedy. No single or partial exercise of such right or remedy shall prevent or restrict the further exercise of that or any other right or remedy.

## 10. SEVERANCE

10.1 If any provision or part-provision of this Warranty is or becomes invalid, illegal or unenforceable, it shall be deemed deleted, but that shall not affect the validity and enforceability of the rest of this Warranty.

10.2 If any provision or part-provision of this Warranty is deemed deleted under clause 10.1 the parties shall negotiate in good faith to agree a replacement provision that, to the greatest extent possible, achieves the intended commercial result of the original provision.

## 11. THIRD PARTY RIGHTS

11.1 This Warranty does not give rise to any rights under the Contracts (Rights of Third Parties) Act 1999 to enforce any term of this Warranty.

## 12. GOVERNING LAW

12.1 This Warranty and any dispute or claim (including non-contractual disputes or claims) arising out of or in connection with it or its subject matter or formation shall be governed by and construed in accordance with the law of England and Wales.

## 13. JURISDICTION

13.1 Each party irrevocably agrees that the courts of England and Wales shall have exclusive jurisdiction to settle any dispute or claim (including non-contractual disputes or claims) arising out of or in connection with this Warranty or its subject matter or formation.

## SCHEDULE 01

Interpretation and Definitions

### 01. INTERPRETATION

The following definitions and rules of interpretation apply in this Warranty.

### 02. DEFINITIONS:

**Business Day:** a day, other than a Saturday, Sunday or public holiday in England, when banks in London are open for business.

**Commencement Date:** shall be the date of completion of the purchase of the Equipment by the Purchaser.

**Equipment:** the equipment purchased by the Purchaser from the Warrantor as is more particularly described in Schedule 1.

**Expiry Date:** shall be the date occurring 12 calendar months after the Commencement Date.

**Maintenance and Servicing Requirements:** the Purchaser's maintenance and servicing requirements for the Equipment as are set out in more detail in Schedule 3.

**Purchaser:** means the purchaser of the Equipment from the Warrantor as more particularly described in Schedule 1.

**Purchase Price:** means the original purchase price of the Equipment as more particularly set out in Schedule 1.

**Usage Cycle Parameters:** the Purchaser's standard parameters for the number of cycles of use in any given period for the Equipment as are set out in more detail in Schedule 2.

**Use Parameters:** the Purchaser's standard design parameters for the safe and appropriate use of the Equipment as are set out in more detail in Schedule 2.

**VAT:** value added tax [or any equivalent tax] chargeable in the UK [or elsewhere].

**Warrantor:** means the warrantor as more particularly described in Schedule 1.

2.1 Clause, Schedule and paragraph headings shall not affect the interpretation of this Warranty.

2.2 A **person** includes a natural person, corporate or unincorporated body (whether or not having separate legal personality).

2.3 The Schedules form part of this Warranty and shall have effect as if set out in full in the body of this Warranty. Any reference to this Warranty includes the Schedules.

2.4 Unless the context otherwise requires, words in the singular shall include the plural and in the plural shall include the singular.

2.5 Unless the context otherwise requires, a reference to one gender shall include a reference to the other genders.

2.6 Any obligation on a party not to do something includes an obligation not to allow that thing to be done.

# EC DECLARATION OF CONFORMITY

## IN ACCORDANCE WITH ISO/IEC 17050-1:2004

Declaration: As defined by the Machinery Directive 2006/42/EC and subsequent amendments

We, CONQUIP ENGINEERING GROUP, herewith declare that the following indicated equipment meets the fundamental health and safety requirements concerning the ISO/IEC 17050-1:2004 guideline(s), due to their design and manufacture.

This declaration will be rendered null and void if the machine is changed without our approval.

**SIGNED:**



**DATED: 2024**

Garry Critchley, Chief Executive Officer

PRODUCT CODES	GENERAL DESCRIPTION / DESIGNATION:	WORKING LOAD LIMIT:
CA530-04000	Smart-Release BulkX 4000	10000kg
CA530-05000	Smart-Release BulkX 5000	10000kg
CA530-06000	Smart-Release BulkX 6000	14000kg
CA530-07000	Smart-Release BulkX 7000	14000kg
CA530-08000	Smart-Release BulkX 8000	20000kg
CA530-010000	Smart-Release BulkX 10000	20000kg
CA530-012000	Smart-Release BulkX 12000	28000kg
CA530-014000	Smart-Release BulkX 14000	28000kg
CA530-016000	Smart-Release BulkX 16000	32000kg

ITEM	CODE	DESCRIPTION
<b>EC DIRECTIVE/REGULATION:</b>	2006/42/EC	New Machinery Directive.
	2011/65/EU	Ref. 2015/863/EU Restrictions of Hazardous Substances Directive.
	2014/35/EU	Low Voltage Equipment Directive.
	2014/30/EU	Electromagnetic Compatibility Directive.
<b>HARMONISED STANDARDS:</b>	ISO 11697:1995	Bases for design of structures. Loads due to bulk materials.
	ISO 12100:201	Safety of Machinery. General principles for design. Risk assessment and risk reduction.
	BS EN 1993-1-1 2005	Eurocode 3. Design of steel structures. General rules and rules for buildings.
	BS EN 1990:2002+A1:2005	Eurocode. Basis of structural design.
	BS EN 60204-32:2008	Safety of Machinery. Electrical equipment of machines Requirements for hoisting machines.
<b>OTHER REGULATIONS:</b>	BS EN 62745:2017	Safety of Machinery. Requirements for cableless control systems of machinery.
	LOLER 1998	Lifting Operations and Lifting Equipment Regulations 1998 (LOLER)
	PUWER 1998	Provision and Use of Work Equipment Regulations 1998 (PUWER)

For any additional information on the standards for the ancillary parts, please contact Conquip Engineering Group.

TALKING TO US IS EASY  
**WE'RE HERE TO HELP**

Call us on 0333 300 3470  
Email us at [sales@cqegroup.com](mailto:sales@cqegroup.com)  
[www.cqegroup.com](http://www.cqegroup.com)

