

USER GUIDE

# COSHH STORE

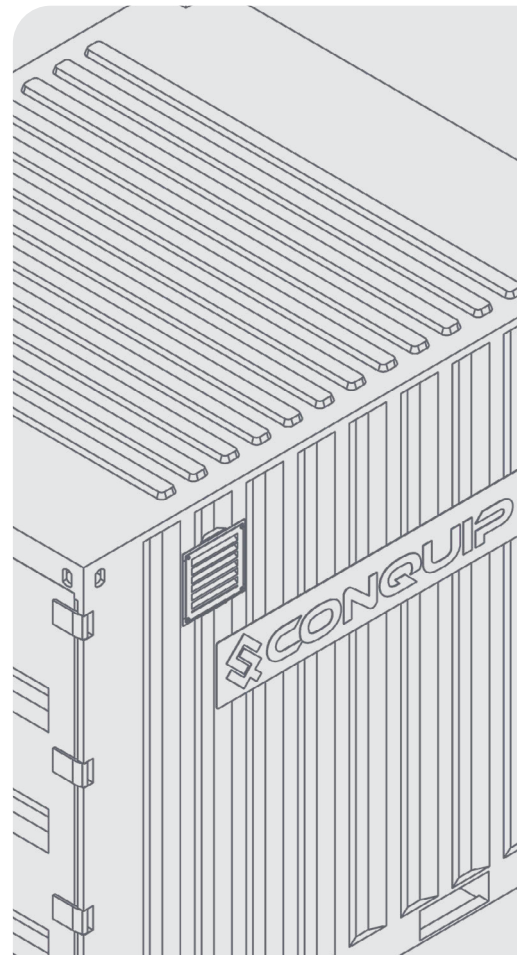

## DISCLAIMER

Do not attempt to handle or operate this equipment before you have received sufficient training. It is imperative that you have read the General Safety Instructions on page 10 and sufficiently familiarised yourself with the Operational Procedures in this document.

Note that this item is compliant only to the standards specified in this User Guide and it is therefore the duty of the responsible person(s) to review and ensure compliance.

# CONTENTS

## PRODUCT INFORMATION

INTRODUCTION	04
SPECIFICATION	05
PARTS DIAGRAM	06

## OPERATIONAL PROCEDURES

IMPORTANT USAGE NOTES	08
LIFTING WITH A FORKLIFT	08
LIFTING WITH A CRANE	09
USAGE INSTRUCTIONS	09

## GENERAL SAFETY INSTRUCTIONS

SAFETY INSTRUCTIONS	10
GENERAL NOTES	11

## LEGAL

TERMS AND CONDITIONS	12
EC DECLARATION OF CONFORMITY	16
STANDARDS AND REGULATIONS APPLICABLE	17

# INTRODUCTION

## OVERVIEW

The Conquip COSHH Store is a walk-in storage container designed for secure storage of chemical and other hazardous or flammable substances.

It has a weather-proof finish and secure, locking doors, preventing unauthorised access and making it ideal for use on a construction site or in a plant yard.

Shelving along one side and across the back of the unit provides suitable storage for smaller items and double doors allow for easy access. Featuring a large 1000 litre spillage sump to prevent hazardous substances causing harm to the environment, the COSHH Store is a best practice solution for storage of 205-litre drums and other smaller containers.

## KEY BENEFITS

- 1000-litre bunded spillage sump with a mesh floor to protect personnel from spillage and ensure minimum contamination of other goods.
- Double doors provide easy access and allow palletised COSHH drums to be placed inside without double handling.
- Lockable doors prevent unauthorised access, providing ultimate security.
- Shelving along one side and the back of the unit provides large storage space for 25-litre and smaller capacity drums.
- Large bund allows for storage of IBCs if required.
- Complete with certified lifting eyes and fork pockets for ease of transportation.
- Best practice COSHH storage option.

# SPECIFICATION

ITEM	PRODUCT CODE
COSHH Store	ST125AF-16000

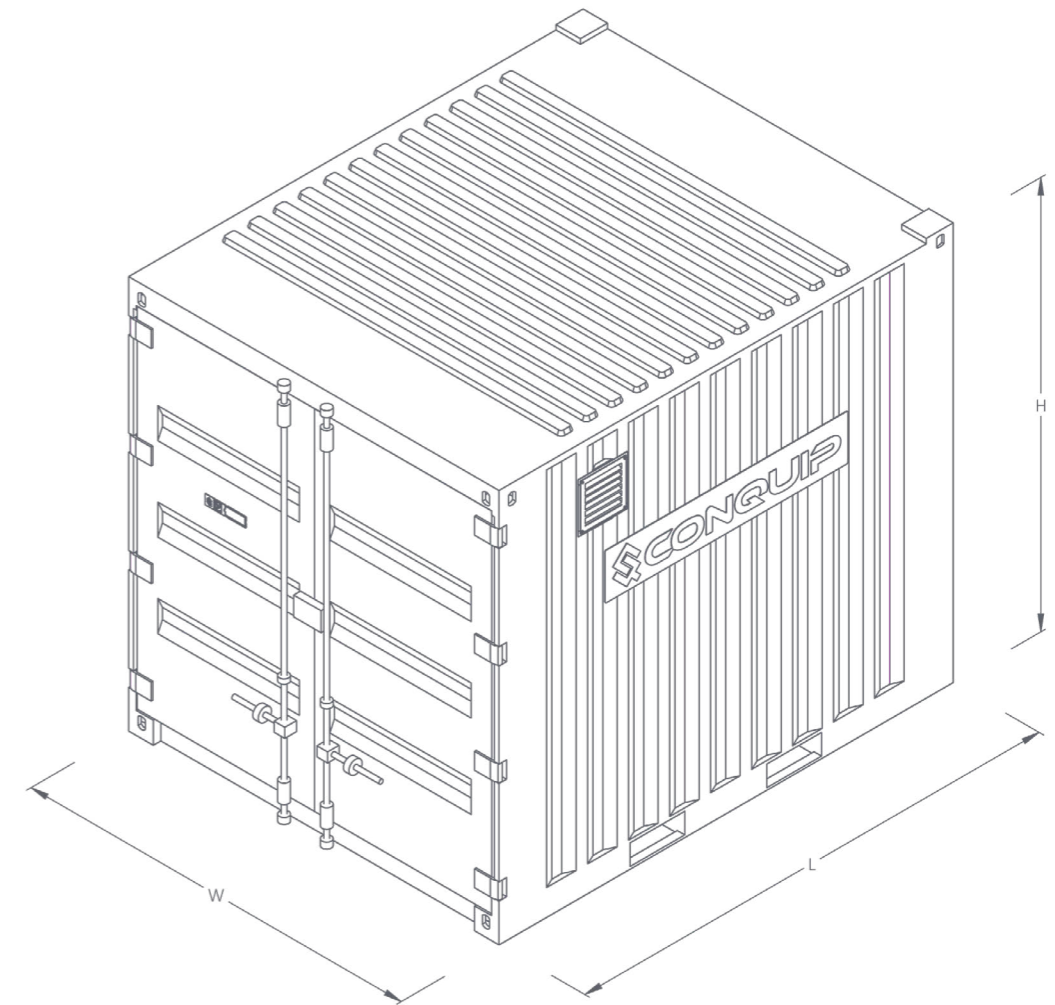

CODE	LENGTH (mm)	WIDTH (mm)	HEIGHT (mm)	WEIGHT (kg)	CAPACITY (litres)	WLL* (per shelf)	WLL* (bund)
ST125AF-16000	3000	2400	2630	2630	1100	700kg	1000kg

\*Working Load Limit

# PARTS DIAGRAM

## COSHH STORE

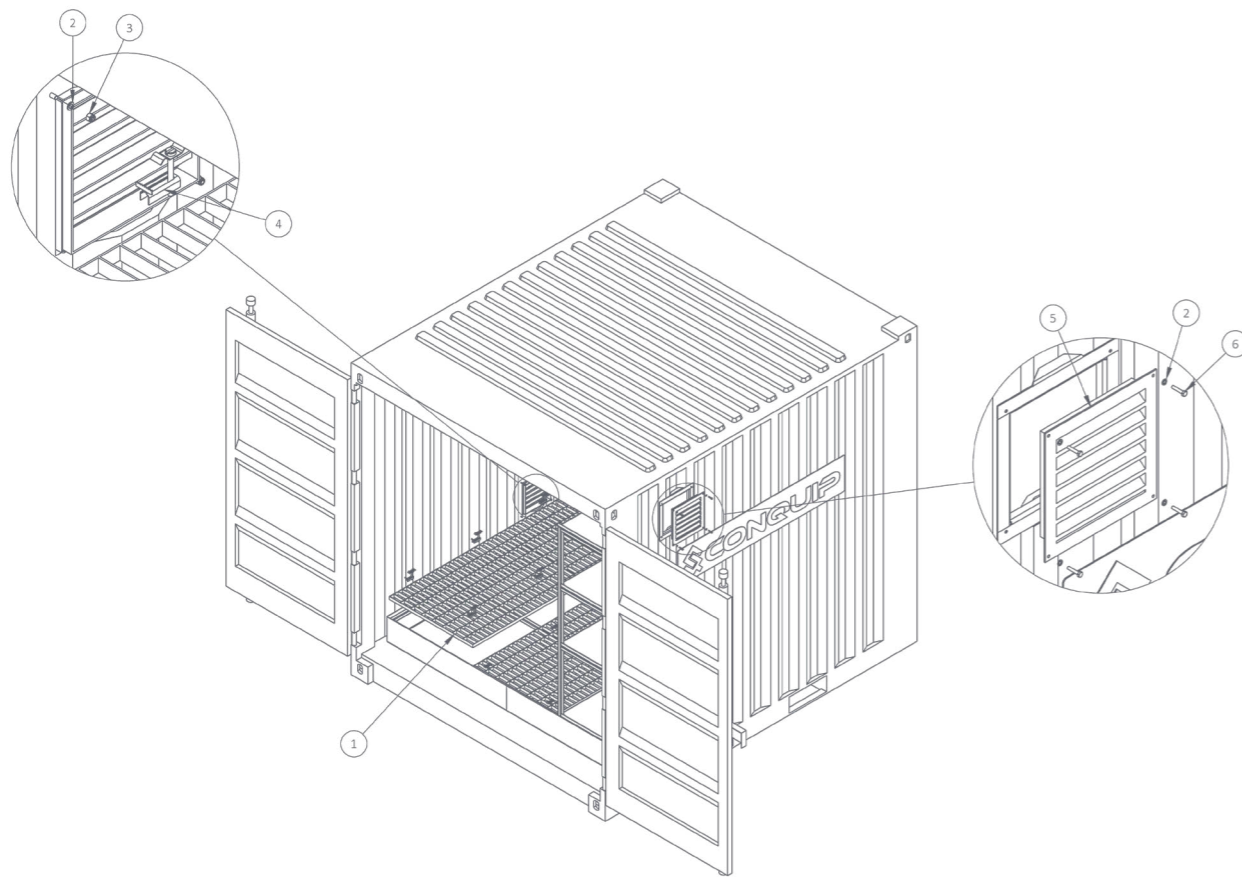

ITEM NUMBER	PART NUMBER	DESCRIPTION	QUANTITY
1	ST125AF-16000-01	Kennedy Grating	2
2	NS800737	M6 Flat Washer	16
3	NS800826	M6 Nyloc Nut	12
4	ZZ980670	Grating Attachment Clamp Fitting	12
5	ZZ990831	Weather Louvre 300mm x 300mm	2
6	NS800996	M6x30 Hex Head Set Screw 8.8	8

NOTE: These parts are for this model, they may differ for previous versions. Please contact Conquip with any queries.

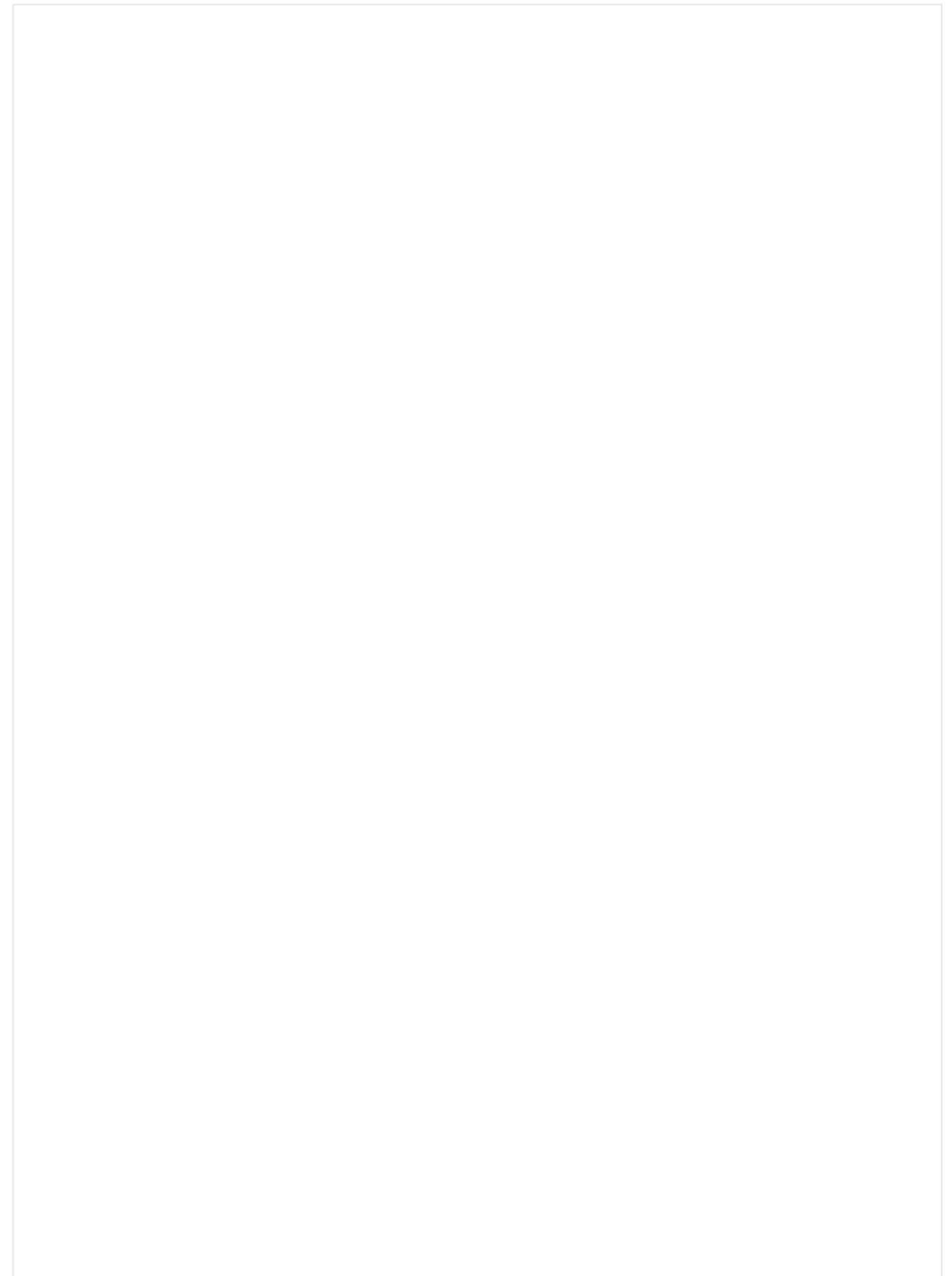

# OPERATIONAL PROCEDURES

## IMPORTANT USAGE NOTES

- The COSHH Store is only designed to be lifted when empty, do not lift if it is being used to store materials.
- Ensure that no container contains more than 1000 litres of liquid.
- Only transport when empty (bund and shelves).
- Check bund regularly for spills. Drain if the bund has fluid in it.
- When loading shelves with large loads, space out suitably to spread the load.

## LIFTING WITH A FORKLIFT

01. To lift the COSHH Store with a forklift, set the machine's forks to the correct width of the fork pockets. Make sure that they are equidistant from the centre.
02. Drive the forklift to the COSHH Store, aligning the forks with the fork pockets.
03. Move the forklift forward until the forks are fully inserted into the fork pockets. The COSHH Store is now ready to lift.
04. Carefully raise the store just off the ground and check for balance and security.
05. Carefully transport the store to its required destination, taking care not to jolt.
06. When in position, the store can be lowered onto firm, level ground.
07. Reverse the forklift back and clear of the store.

## LIFTING WITH A CRANE

01. Attach a suitable four-leg chain sling to the four lifting points.
02. Carefully raise the store just off the ground and check for balance and security.
03. Carefully transport the store to its required destination, taking care not to jolt.
04. When in position, the store can be lowered on to firm, level ground.
05. Detach the store from the lifting chains.

## USAGE INSTRUCTIONS

01. Load as required, using the shelving inside the store.
02. Ensure the doors are shut and securely locked when the store is not in use or being supervised. It is the responsibility of the supervisor to ensure that no harmful chemicals are removed by unauthorised users.
03. If a spillage occurs, it can safely and easily be cleaned up by removing the mesh grating on the floor and washing down. Ensure the mesh is refitted once cleaned.
04. To empty the bund, unlock the grating clamps and use a minimum of two operatives to remove the grating. Place grating to one side and remove spilt waste by pumping it out into a suitable hazardous waste bin.
05. Once all of the waste has been removed from the bund, pick up the grating and place back in position on top of the bund. Secure with the grating clamps.

# GENERAL SAFETY INSTRUCTIONS

The equipment should be properly operated and maintained to keep it in a safe, efficient operating condition. Be sure that all fixings and components are free of mud or other matter that might cause issues hazardous to the operator, serviceman, or other personnel or equipment. Report all malfunctions to those responsible for maintenance, and do not operate the equipment until corrected. Normal service or maintenance performed as required can prevent unexpected and unnecessary downtime.

This operations manual describes general inspections, servicing and operation with the normal safety precautions required for normal servicing and operating conditions. It is not a guide, however, for abnormal conditions or situations, and therefore, servicemen and operators must be safety conscious and alert to recognise potential servicing or operating safety hazards at all times, and take necessary precautions to assure safe servicing and operation of the machine.



**M002**  
Refer to instructions manual



**M004**  
Wear eye protection



**M008**  
Wear safety footwear



**M009**  
Wear protective gloves



**M010**  
Wear protective clothing



**M014**  
Wear head protection



**M015**  
Wear high-visibility clothing

## GENERAL NOTES

- Read this operations manual and learn the operating characteristics and limitations of the equipment. Know what operating clearances the machine requires.
- Read and understand all the safety signs prior to operation.
- If the safety signs are obstructed by dirt or debris, clean them using mild soap and water prior to operation.
- If the safety signs are damaged or illegible, replace them immediately, prior to operation.
- Be aware of operating hazards that weather changes can create on the job. Know proper procedures to follow when a severe rain or electrical storm strikes.
- Never attempt to operate or work on equipment when not feeling physically fit.
- Never wear loose clothing, rings, watches, heavy gloves etc., that might catch and result in injury.
- Know what safety equipment is required and use it. Such equipment may be: hard hat, safety glasses, reflector type vests, protective gloves and safety footwear.

# TERMS & CONDITIONS

## CONQUIP ENGINEERING GROUP STANDARD PRODUCT WARRANTY

### 01. COMMENCEMENT

1.1 This Warranty shall commence on the Commencement Date and shall continue until the earlier of:

- (a) the Expiry Date; or
- (b) the date on which it may be voided in accordance with clause 4.1(b)

when it shall terminate automatically without notice.

### 02. DUTY OF GOOD FAITH

2.1 The Purchaser shall in the exercise of its rights under this Warranty and in the compliance with its obligations under this Warranty be subject to and shall in all respects owe and comply with a duty of good faith to the Warrantor.

### 03. NATURE AND EXTENT OF COVER

3.1 Subject to clause 3.2 the Warrantor agrees and undertakes to the Purchaser that it shall be liable to the Purchaser under and in accordance with the terms of this Warranty in the event that:

- (a) prior to the Expiry Date the Purchaser shall notify a Warranty Claim to the Warrantor; and
- (b) the Equipment or any relevant part of the Equipment shall have become unusable as the result of defective material or defective workmanship prior to the Expiry Date.

3.2 The Warrantor's obligation under clause 3.1 shall be expressly subject to the provisions of clauses 4, 5 and 6 and conditional upon the Purchaser's compliance in full with the provisions of clause 7.

### 04. RESTRICTIONS

4.1 The following restrictions apply to this Warranty:

(a) This Warranty is personal to the Purchaser and neither the legal benefit nor legal burden of this warranty may be assigned or novated or otherwise transferred by the Purchaser to any other party. Any purported assignment, novation or transfer shall not be binding upon the Warrantor.

(b) This Warranty shall be void in the event that the Purchaser:

(i) cannot provide authentic and original documentary evidence that the Purchaser has during the period between the Commencement Date and the Expiry Date complied with the Maintenance and Servicing Requirements; and/or

(ii) has, during the period between the Commencement Date and the Expiry Date, exceeded the Purchaser's Usage Cycle Parameters; and/or

(iii) has, during the period between the Commencement Date and the Expiry Date, exceeded the Purchaser's Use Parameters; and/or

(iv) has carried out, or procured the carrying out by any third party of, any repair to the Equipment or any part of the Equipment which is not an Authorised Repair; and/or

(v) has operated the Equipment after having replaced any part of the Equipment with a part which has not been supplied and fitted by the Warrantor; and/or

(vi) has modified the Equipment in any way prior to use.

### 05. EXCLUSIONS

5.1 The following are excluded from the scope of this Warranty:

(a) Loss of and/ or damage to the Equipment or any part of it resulting from any collision between the Equipment and any other fixed or stationary or mobile object whatsoever, irrespective of whether that collision was or was not caused by the Purchaser; and/or

(b) Loss of and/or damage to any personal property and/or possessions or other equipment not forming part of the Equipment but which is present in or about the Equipment; and/or

(c) loss and/or damage which is covered by any other insurance policy taken out and maintained by the Purchaser or in respect of which the Purchaser has a contractual obligation to do so; and/or

(d) loss and/or damage to the equipment which is consistent with the use by the Purchaser of the Equipment:

(i) in compliance with the Maintenance and Servicing Requirements; and

(ii) in compliance with the Usage Cycle Parameters; and

(iii) in compliance with the Use Parameters; and

(iv) having only carried out Authorised Repairs to the Equipment; and

(v) having all and any replacement parts fitted by the Warrantor; and

(vi) in unmodified form.

## 06. LIMITATION OF LIABILITY

6.1 The Warrantor's liability to the Purchaser shall be limited as follows:

- (a) The Warrantor shall not in any circumstances be liable to the Purchaser for indirect and/or consequential and/or economic loss suffered and/or incurred as the case may be by the Purchaser; and
- (b) The Warrantor shall only be liable to the Purchaser for the reasonable and proper costs reasonably and properly incurred by the Purchaser directly in connection with the repair and/or replacement (at the Warrantor's absolute discretion) of the Equipment or any part of the Equipment; and
- (c) The Warrantor's liability to the Purchaser shall notwithstanding any other provision of this Warranty, not in any circumstances exceed the Purchase Price of the Equipment.

## 07. WARRANTY CLAIMS

7.1 The Purchaser shall in respect of any claim against the Warrantor under this Warranty and within 24 hours of the occurrence of the subject matter of the Warranty Claim:

- (a) Complete in full and submit to the Warrantor a Warranty Claim in the form annexed to Schedule 4;
- (b) Provide date stamped or date identifiable photographs evidencing the claim; and
- (c) Make the Equipment or the relevant part of the Equipment available to the Warrantor for inspection within 48 hours of notification of the relevant Warranty Claim.

## 08. ENTIRE AGREEMENT

8.1 This Warranty constitutes the entire agreement between the parties and supersedes and extinguishes all previous promises, assurances, warranties, representations and understandings between them, whether written or oral, relating to its subject matter.

8.2 Each party agrees that it shall have no remedies in respect of any statement, representation, assurance or warranty (whether made innocently or negligently) that is not set out in this Warranty. Each party agrees that it shall have no claim for innocent or negligent misrepresentation or negligent misstatement based on any statement in this Warranty.

No variation of this Warranty shall be effective unless it is in writing and signed by the parties (or their authorised representatives).

## 09. WAIVER

No failure or delay by a party to exercise any right or remedy provided under this Warranty or by law shall constitute a waiver of that or any other right or remedy, nor shall it prevent or restrict the further exercise of that or any other right or remedy. No single or partial exercise of such right or remedy shall prevent or restrict the further exercise of that or any other right or remedy.

## 10. SEVERANCE

10.1 If any provision or part-provision of this Warranty is or becomes invalid, illegal or unenforceable, it shall be deemed deleted, but that shall not affect the validity and enforceability of the rest of this Warranty.

10.2 If any provision or part-provision of this Warranty is deemed deleted under clause 10.1 the parties shall negotiate in good faith to agree a replacement provision that, to the greatest extent possible, achieves the intended commercial result of the original provision.

## 11. THIRD PARTY RIGHTS

11.1 This Warranty does not give rise to any rights under the Contracts (Rights of Third Parties) Act 1999 to enforce any term of this Warranty.

## 12. GOVERNING LAW

12.1 This Warranty and any dispute or claim (including non-contractual disputes or claims) arising out of or in connection with it or its subject matter or formation shall be governed by and construed in accordance with the law of England and Wales.

## 13. JURISDICTION

13.1 Each party irrevocably agrees that the courts of England and Wales shall have exclusive jurisdiction to settle any dispute or claim (including non-contractual disputes or claims) arising out of or in connection with this Warranty or its subject matter or formation.



# EC DECLARATION OF CONFORMITY

## IN ACCORDANCE WITH EN ISO 17050-1:2004

Declaration: As defined by the Equipment Directive 2006/42/EC and subsequent amendments

We, CONQUIP ENGINEERING GROUP, herewith declare that the following indicated equipment meets the fundamental health and safety requirements concerning the EU guideline(s), due to their design and manufacture.

This declaration will be rendered null and void if the machine is changed without our approval.

**SIGNED:**

**DATED: 2024**

---

Garry Critchley, Chief Executive Officer

PRODUCT CODES	GENERAL DESCRIPTION / DESIGNATION	WORKING LOAD LIMIT
ST125AF-16000	COSHH Store	N/A

ITEM	CODE	DESCRIPTION
<b>EC DIRECTIVE/REGULATION</b>	2006/42/EC	Directive 2006/42/EC- new equipment directive
<b>HARMONISED STANDARDS</b>	BS EN ISO 12100:2010	Safety of equipment General principles for design Risk assessment and risk reduction
<b>OTHER REGULATIONS</b>	LOLER 1998	Lifting Operations and Lifting Equipment Regulations 1998 (LOLER)
	PUWER 1998	Provision and Use of Work Equipment Regulations 1998 (PUWER)

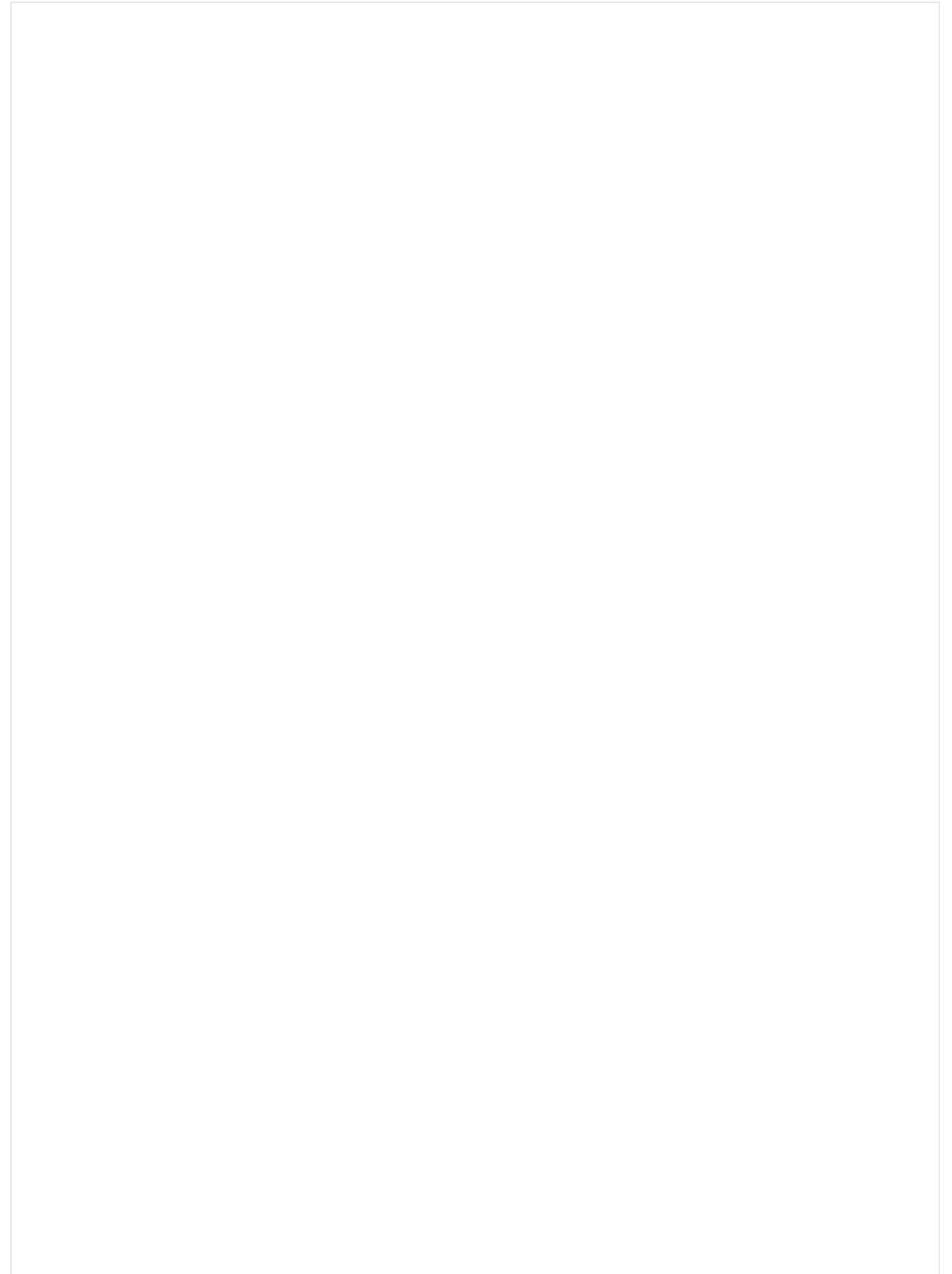
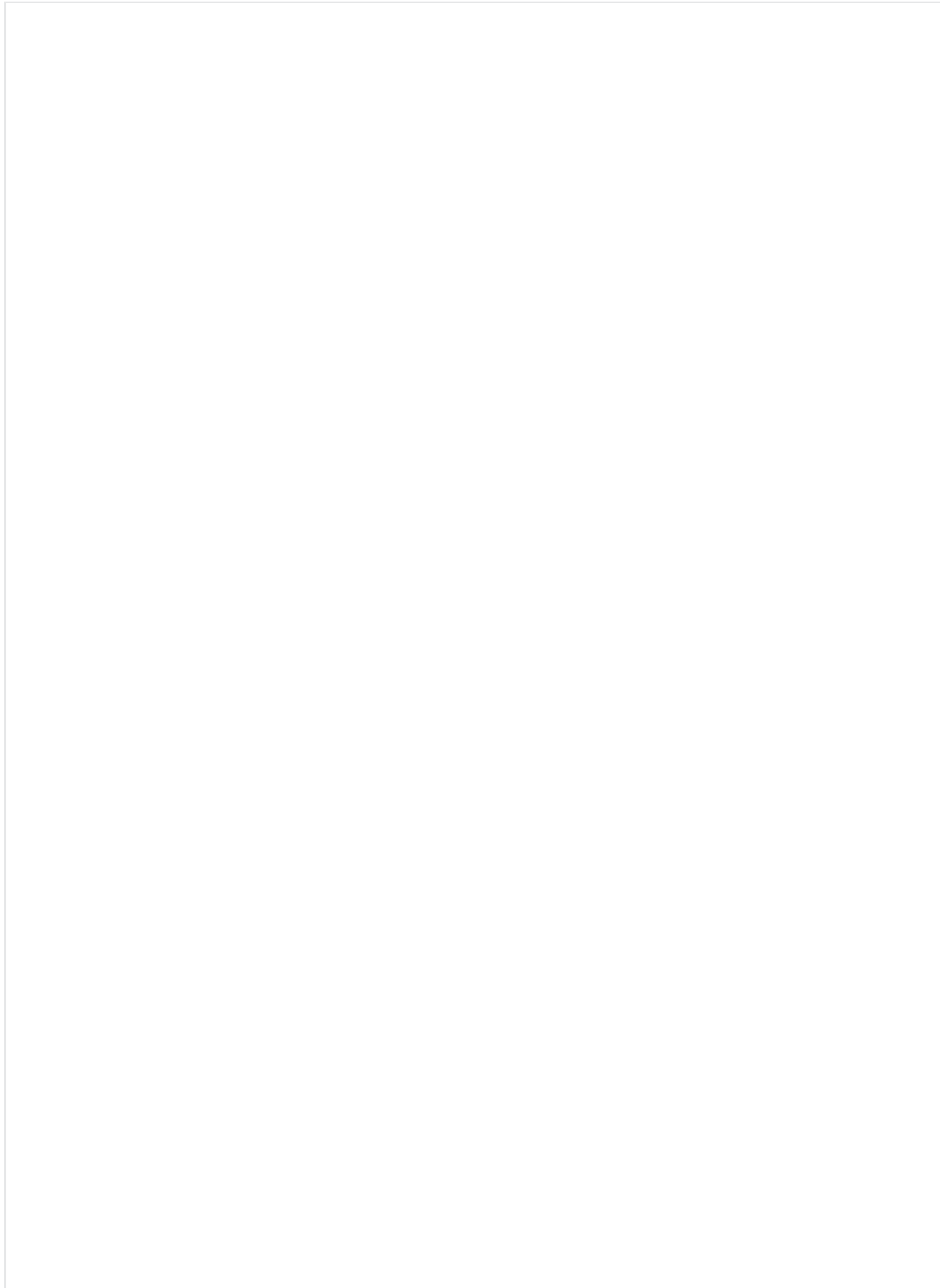

TALKING TO US IS EASY  
**WE'RE HERE TO HELP**

Call us on 0333 300 3470  
Email us at [sales@cqegroup.com](mailto:sales@cqegroup.com)  
[www.cqegroup.com](http://www.cqegroup.com)

