

USER GUIDE

# EXCAVATOR MECHANICAL PIPE LIFTER

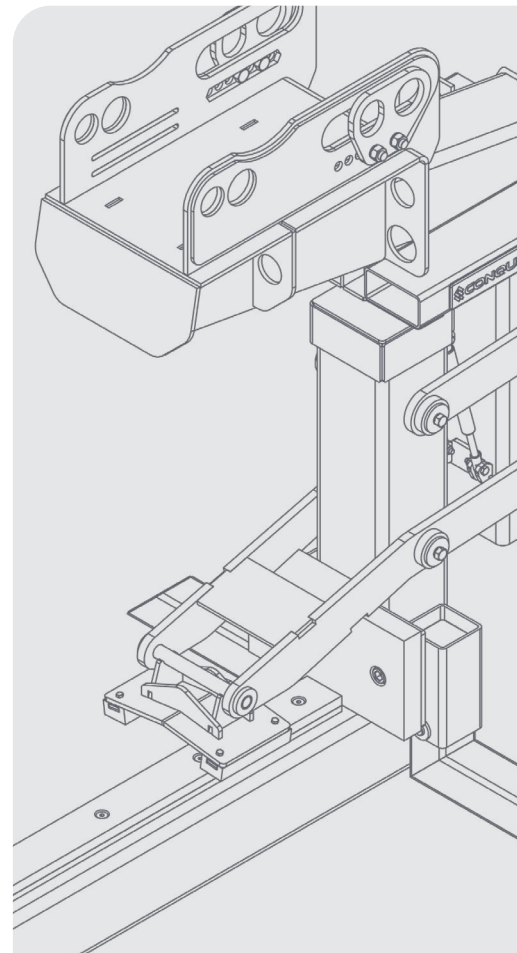

# DISCLAIMER

Do not attempt to handle or operate this equipment before you have received sufficient training. Before use, operatives must have carried out all checks featured on the Visual Inspection Sheet on page 15. It is imperative that you have read the General Safety Instructions on page 16 and sufficiently familiarised yourself with the Operational Procedures in this document.

Note that this item is compliant only to the standards specified in this User Guide and it is therefore the duty of the responsible person(s) to review and ensure compliance.

# CONTENTS

## PRODUCT INFORMATION

INTRODUCTION	04
SPECIFICATION	05
PARTS DIAGRAM	06

## OPERATIONAL PROCEDURES

IMPORTANT USAGE NOTES	12
SAFE PIPE LIFTING	12
SET UP	13
TO LIFT A PIPE	13

## MAINTENANCE & INSPECTION

MAINTENANCE REGIME	14
VISUAL INSPECTION SHEET	15

## GENERAL SAFETY INSTRUCTIONS

SAFETY INSTRUCTIONS	16
GENERAL NOTES	17

## LEGAL

TERMS AND CONDITIONS	18
EC DECLARATION OF CONFORMITY	22
STANDARDS AND REGULATIONS APPLICABLE	23

# INTRODUCTION

## OVERVIEW

The Conquip Excavator Mechanical Pipe Lifter is an excavator attachment used for fast and safe handling of pipe sections. This device can be used for unloading pipes from delivery vehicles, transportation around site and placement in trenches.

The mechanically operated clamp with a grip ensures that the pipe is held securely while being transported. The pipe lifter avoids the need for ground workers to be in the trench during pipe installation and replaces traditional slinging methods for unloading trucks.

## KEY BENEFITS

- Integrated fork pockets for easy transportation short distances around site.
- Adjustable pin centres to suit any quick hitch.
- Integrated rubber production buffers to prevent damage to pipe sections.
- Long clamping arm to prevent damage to pipe sections.
- In-built stand with removable feet enables unit to sit upright for quick connection and release.
- Excavator Mechanical Pipe Lifter 4000 can be supplied with 65 or 80mm pins to suit 13-22T excavators.
- Excavator Mechanical Pipe Lifter 6000 can be supplied with 90, 100 or 110mm pins to suit 30-50T excavators.
- Large lifting capacity of 4000kg or 6000kg working load limit, depending on the model.

# SPECIFICATION

## THE RANGE



PRODUCT CODE	TYPE	WEIGHT (kg)	WLL* (kg)
EA015AD-04000	Excavator Mechanical Pipe Lifter 4000	590	4000
EA015AE-06000	Excavator Mechanical Pipe Lifter 6000	910	6000

\*Working Load Limit

# SPECIFICATION

## EXCAVATOR MECHANICAL PIPE LIFTER 4000

ITEM	PRODUCT CODE
Excavator Mechanical Pipe Lifter 4000	EA015AD-04000

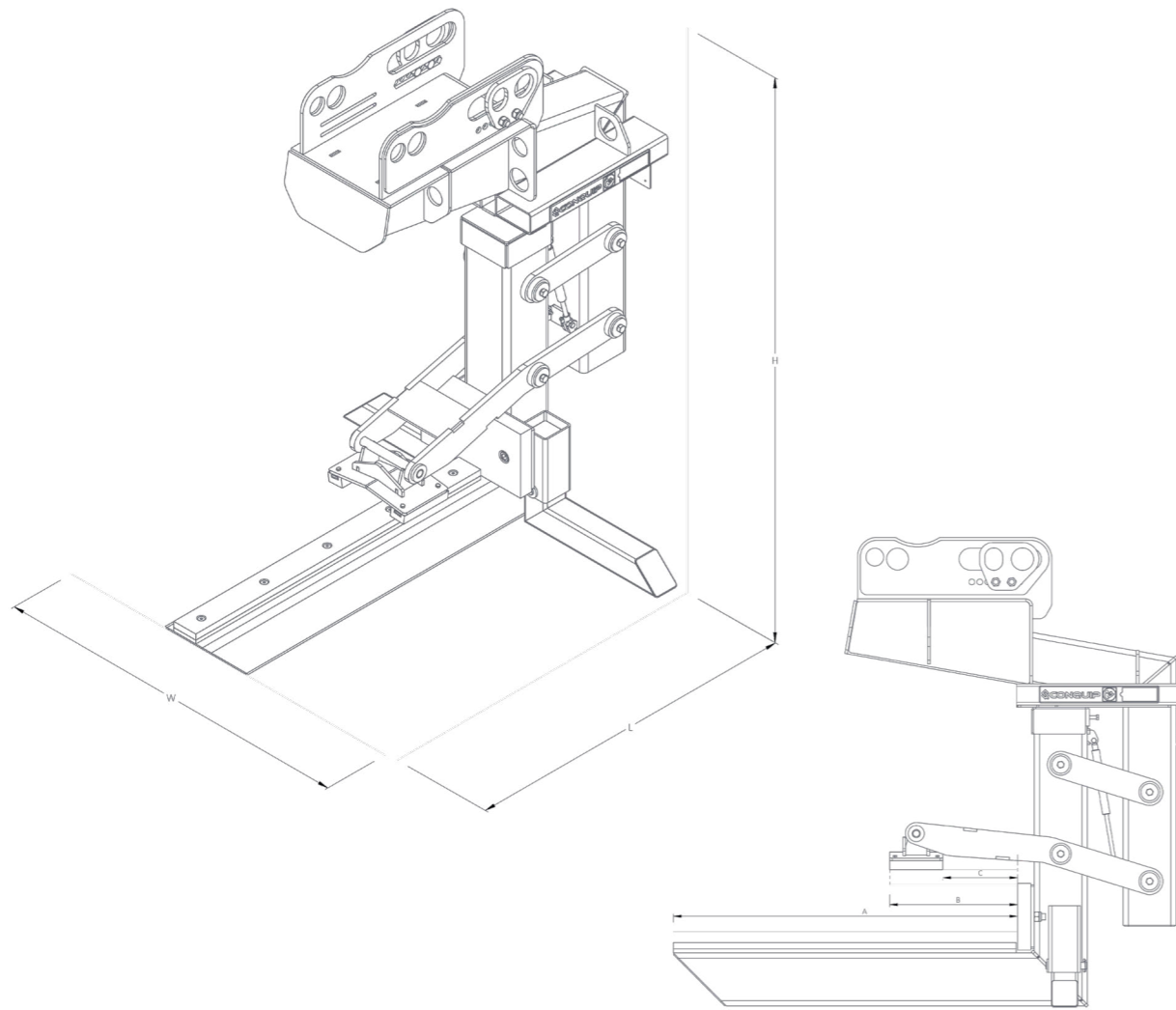

LENGTH (mm)	WIDTH (mm)	HEIGHT (mm)	LOWER BOOM LENGTH (mm)	CLAMPING ARM LENGTH (mm)	CLAMP TO BUFFER LENGTH (mm)
1940	1460	1910	1300	480	280

# SPECIFICATION

## EXCAVATOR MECHANICAL PIPE LIFTER 6000

ITEM	PRODUCT CODE
Excavator Mechanical Pipe Lifter 6000	EA015AE-06000

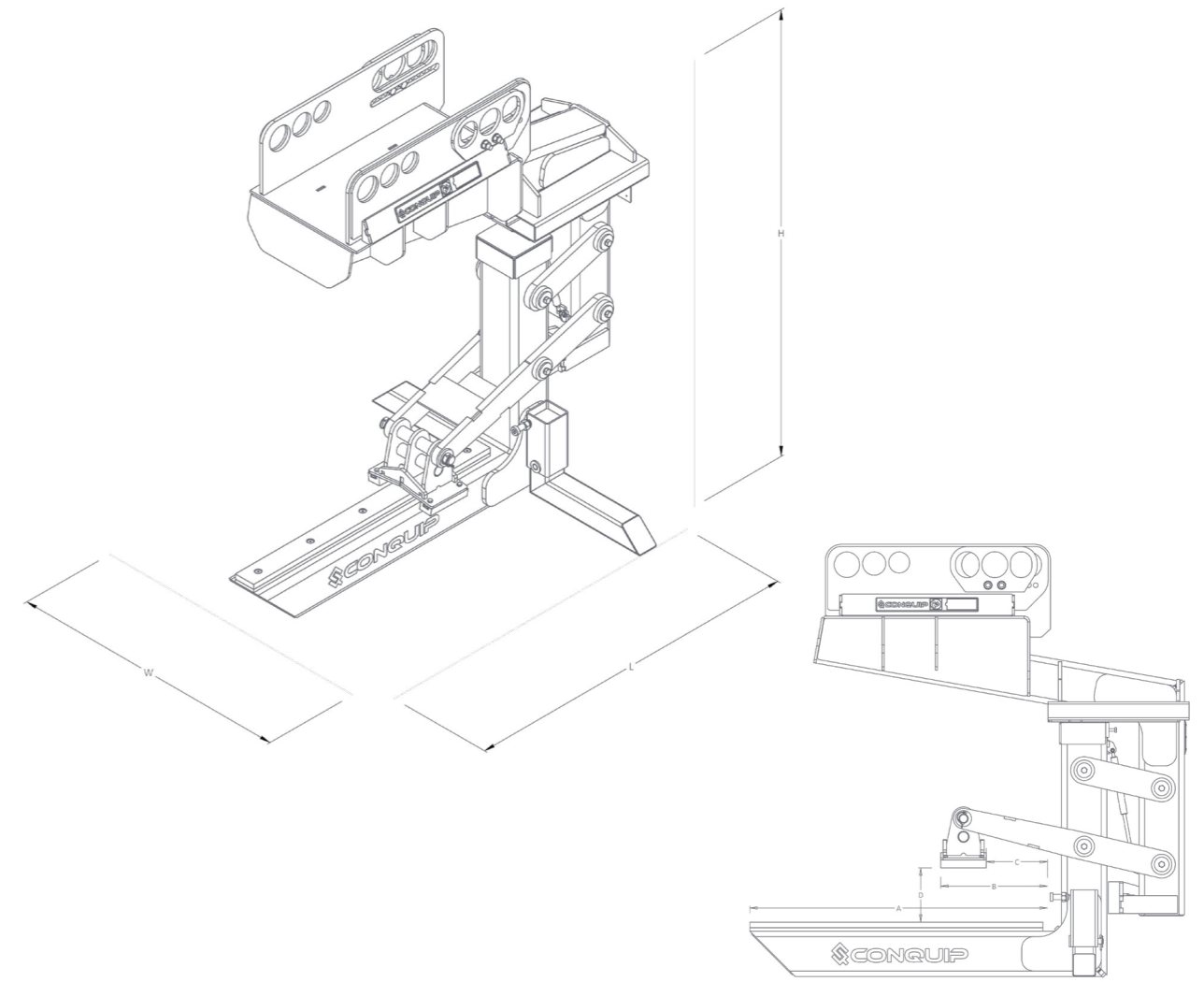

LENGTH (mm)	WIDTH (mm)	HEIGHT (mm)	LOWER BOOM LENGTH (mm)	CLAMPING ARM LENGTH (mm)	CLAMP TO BUFFER LENGTH (mm)
1940	1460	1910	1309	470	270

# PARTS DIAGRAM

## EXCAVATOR MECHANICAL PIPE LIFTER 4000

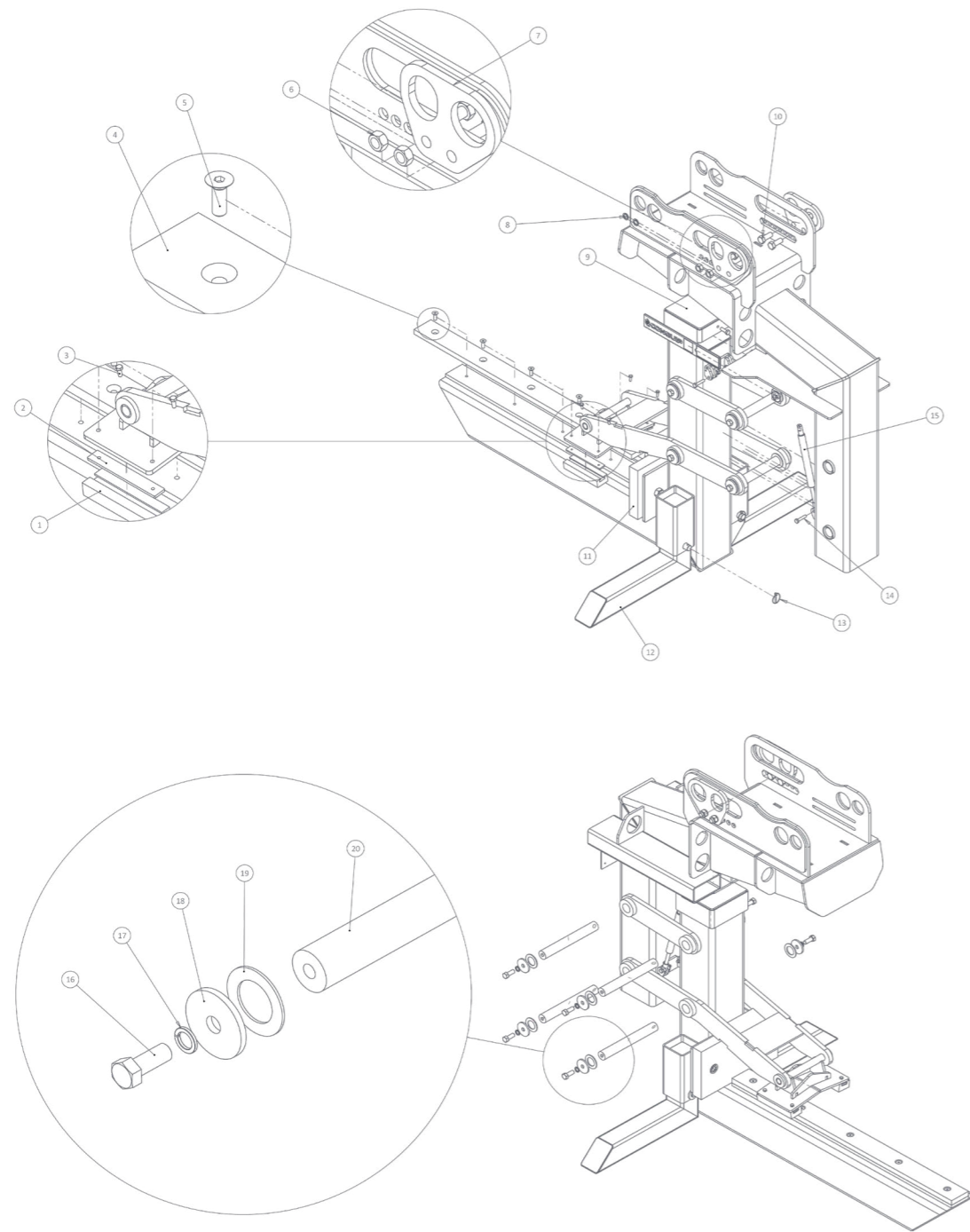

# PARTS DIAGRAM

## EXCAVATOR MECHANICAL PIPE LIFTER 4000

ITEM NUMBER	PART	DESCRIPTION	QUANTITY
1	EA015AD-04000-03-09	Rubber Grip	2
2	EA015AD-04000-03-10	Clamp Plater For Rubber Grip	2
3	NS800160	M8x20 Hex Head Bolt 8.8	4
4	EA015AD-04000-02-06	Support For Horizontal Rubber	1
5	NS800365	M12 x 35 Countersunk Socket Screw	5
6	NS800280	M20 Full Nut	4
7	ZZ130137	Type 2 Adjustment Plate	2
8	NS800886	M20 Spring Washer	4
9	EA015AD-04000-09	Clamp Plate	1
10	NS800878	M20x50 Hex Head Set Screw 8.8	4
11	EA015AD-04000-02-08	Polyurethane Buffer – 450x250x50mm	1
12	EA015AD-04000-04	Feet Assembly	2
13	ZZ990010	Linch Pin 4.5mm	2
14	NS800815	M10x50 Hex Head Set Screw 8.8	4
15	ZZ960113	Gas Strut 1750N	2
16	NS800379	M16x40 Hex Head Bolt 8.8	8
17	NS800249	M16 Spring Washer	8
18	EA015AD-04000-12	Washer	8
19	EA015AD-04000-11	Washer	8
20	EA015AD-04000-10	Pivot Pin	4

NOTE: These parts are for this model, they may differ for previous versions. Please contact Conquip with any queries.

# PARTS DIAGRAM

## EXCAVATOR MECHANICAL PIPE LIFTER 6000

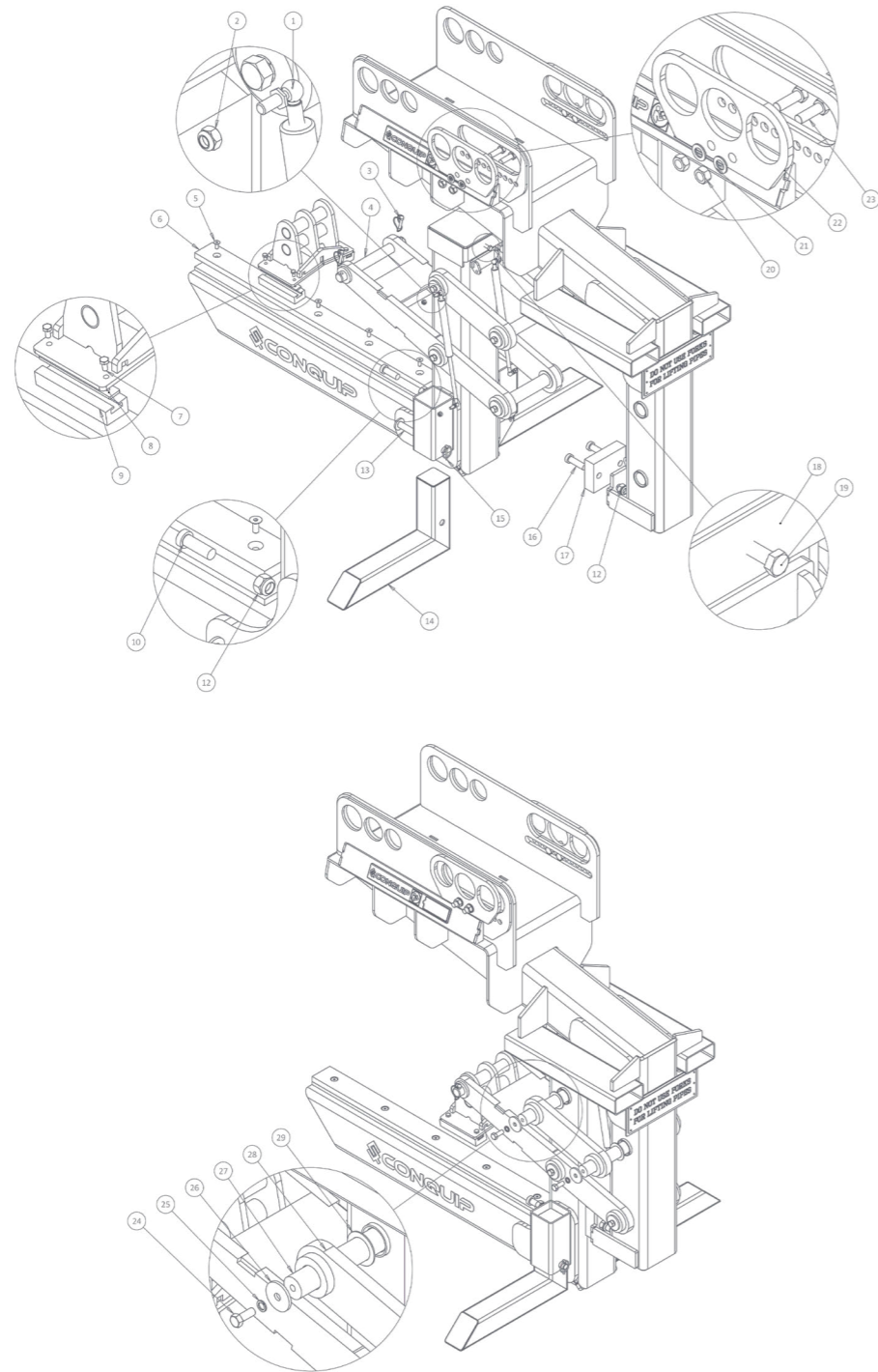

# PARTS DIAGRAM

## EXCAVATOR MECHANICAL PIPE LIFTER 6000

ITEM NUMBER	PART	DESCRIPTION	QUANTITY
1	Gas Strut 2200N	Gas Strut 2200N- Ball Joint Ends	2
2	NS800013	M10 Nyloc Nut	4
3	ZZ960102	10mm Locking Pin	2
4	EA015AE-06000-03-03	Adjustable Pin	1
5	Socket Screw	M12x30 Socket Countersunk Head Screw	5
6	EA015AE-06000-07	Polyurethane Buffer	1
7	Hex Head Screw	M10x20 Hex Head Set Screw 8.8	4
8	EA015AE-06000-03-02-05	Clamp Plate for Rubber Grip	2
9	EA015AE-06000-03-02-06	Rubber Grip	2
10	Cap Screw	M24 x 80 Low Head Cap Screw	2
11	EA015AE-06000-02-08	Rubber End Tile	1
12	NS800122	M24 Nyloc Nut	4
13	EA015AE-06000-06	Pin Assembly	2
14	EA015AE-06000-06	Feet Assembly	2
15	ZZ990009	Linch Pin 6mm x 42mm	2
16	Cap Screw	M24 x 80 Low Head Cap Screw	2
17	EA015AE-06000-01-23	Rubber End Tile	1
18	EA015AE-06000-09	Clamp Plate	1
19	NS800014	M12x35 Hex Head Bolt 8.8	1
20	NS800280	M20 Full Nut	4
21	NS800668	M20 Flat Washer	4
22	ZZ130151	Adjustment Plate	2
23	Hex Head Bolt	M20x60 Hex Head Bolt 8.8	2
24	NS800379	M16x40 Hex Head Bolt 8.8	8
25	NS800249	M16 Spring Washer	8
26	EA015AE-06000-08	Washer	8
27	EA015AE-06000-10	Pivot Pin	4
28	EA015AE-06000-05	Connector Top Bracket	2
29	EA015AE-06000-11	Washer	8

NOTE: These parts are for this model, they may differ for previous versions. Please contact Conquip with any queries.

# OPERATIONAL PROCEDURES

## IMPORTANT USAGE NOTES

- Ensure the work area is firm and level and clear of all obstructions with adequate room around the unit for the operator to work safely.
- Be careful not to apply too much force when pushing pipe sections together to avoid breakage of pipes.
- Check that the quick hitch is securely attached to the excavator arm, following the manufacturer's instructions and giving special attention to any safety features.
- Only lift one pipe section at a time.
- There are a number of crush points on the pipe lifter. Before using, please be aware of where these are and keep hands and feet clear of these areas at all times when in use.
- The excavator operator should never leave the excavator while a pipe is suspended or being gripped by the Excavator Mechanical Pipe Lifter.
- Do not use the in-built stand for pushing or manoeuvring the pipe into place.
- The feet can be removed from the in-built stand to accommodate pipe laying in narrow trenches. The feet must then be replaced before the unit is unhitched after use.
- The 4t Excavator Mechanical Pipe Lifter is designed for pipes with an internal diameter of 350mm or greater.

## SAFE PIPE LIFTING

To determine what length of pipe can be safely lifted by our Excavator Mechanical Pipe Lifter, we work on the pipe being 1.5 times the length of the unit's lower boom.

However, this is dependent on the diameter of the pipe - the smaller the diameter, the longer the pipe that can be lifted. The excavator deration chart must also be considered with regards to the weight of the load that you are lifting.

## SET UP

01. Select the correct size pins for your machine's quick hitch.
02. Fit the front pin to the correct sized hole on the attachment, while the attachment is standing upright on its in-built stand.
03. Adjust the position of the rear pin to suit the quick hitch - follow the quick hitch operating guidelines and set the pins to the maximum centres for the unit.
04. Ensure the quick hitch pins have the retaining bolts correctly fitted.
05. Check for debris in the quick hitch locking mechanism and check the fit of the unit on the quick

hitch. Do not use if not secure.

06. Determine the width of your trench. If it is too narrow to fit the full width of the Excavator Mechanical Pipe Lifter, the feet can be removed from the in-built stand. To do this, remove the linch and retaining pins from the feet, raise the unit off the ground, leaving the feet on the ground.
07. When moving pipes, operators should be aware that the pipes may roll and should have a method prepared for securing the pipes.

## TO LIFT A PIPE

01. When it is safe to proceed, raise the pipe lifter until the tip is just below the crown of the pipe section, then insert the lower boom into the bore of the pipe until it is fully inserted and the rubber buffer at the back of the lifter is touching the pipe.
02. Raise the pipe lifter carefully and keep it level, so that the boom comes in contact with the inside of the pipe.
03. Continue to slowly raise the pipe lifter; the action of the weight of the pipe on the boom will trigger the clamping arm to lower onto the pipe.
04. When the load is fully raised from the ground or delivery vehicle, and clamped and stable, it is safe to proceed and transport the pipe section to its destination.
05. When travelling with a load, keep it in the lowest practicable position to maintain driver visibility. Operators should allow for any rough or sloping ground when assessing the method of operating.
06. Carefully lower the pipe onto the ground or storage location, taking care of edges or other items on hard ground.
07. If laying pipes into a trench, the pipe lifter can be tilted up to 30° to allow the pipe to be lowered and placed accurately.
08. Once lowered to the ground, as the weight of the pipe transfers from the boom to the ground, the clamp will release, allowing the boom of the pipe lifter to be extracted from the pipe.
09. If laying pipework, the rubber buffers can be used to push the pipe sections together.

## AFTER USE

01. Place the Excavator Mechanical Pipe Lifter in a safe area for storage using the in-built stand to keep the unit upright.
02. If the feet have been removed to accommodate pipe laying in narrow trenches, they must be replaced before the unit is unhitched and secured with the retaining and linch pins.

# MAINTENANCE & INSPECTION

## MAINTENANCE REGIME

- It is mandatory that the equipment is thoroughly examined regularly, by a qualified engineer, to ensure compliance with relevant regulations. Conquip recommend carrying out a thorough examination every six months.
- This equipment may incorporate various loose and detachable items including, but not limited to pins, bolt assemblies and adaption plates. Refer to the separate requirements for the safe use of those items.
- When not being used, store the unit in a clean, upright condition and in a safe place where it will be protected from thieves and unauthorised users.
- This equipment must be inspected by the responsible person before each use and then regularly, as determined by your risk assessment or working practice. If you have any concerns about the equipment's condition or suitability, do not use it.

## VISUAL INSPECTION CHECKLIST

INSPECTION ITEMS	RESULTS		COMMENTS
	SATISFACTORY	UNSATISFACTORY	
Serial Number			CQ.....
Product Code			
Working Load Limit (kg)			
Conforms to user guide specification			
Adjuster plate bolts tight			
Excavator pins secured			
Rubber grippers worn or damaged			
Pivot pin bolts tight			
Gas struts leaking			
Clamping arm operational			
Stand leg pins in place / secured			
General visual body inspection			
<b>SIGNATURE</b>			
Name	Position	Qualification	Signature & Date



# GENERAL SAFETY INSTRUCTIONS

The equipment should be properly operated and maintained to keep it in a safe, efficient operating condition. Be sure that all fixings and components are free of mud or other matter that might cause issues hazardous to the operator, serviceman, or other personnel or equipment. Report all malfunctions to those responsible for maintenance, and do not operate the equipment until corrected. Normal service or maintenance performed as required can prevent unexpected and unnecessary downtime.

This operations manual describes general inspections, servicing and operation with the normal safety precautions required for normal servicing and operating conditions. It is not a guide, however, for abnormal conditions or situations, and therefore, servicemen and operators must be safety conscious and alert to recognise potential servicing or operating safety hazards at all times, and take necessary precautions to assure safe servicing and operation of the equipment.



**M002**  
Refer to instructions manual



**M004**  
Wear eye protection



**M008**  
Wear safety footwear



**M009**  
Wear protective gloves



**M010**  
Wear protective clothing



**M014**  
Wear head protection



**M015**  
Wear high-visibility clothing

## GENERAL NOTES

- Read this operations manual and learn the operating characteristics and limitations of the equipment. Know what operating clearances the machine requires.
- Read and understand all the safety signs prior to operation.
- If the safety signs are obstructed by dirt or debris, clean them using mild soap and water prior to operation.
- If the safety signs are damaged or illegible, replace them immediately, prior to operation.
- Be aware of operating hazards that weather changes can create on the job. Know proper procedures to follow when a severe rain or electrical storm strikes.
- Never attempt to operate or work on machinery when not feeling physically fit.
- Never wear loose clothing, rings, watches, heavy gloves etc., that might catch and result in injury.
- Know what safety equipment is required and use it. Such equipment may be: hard hat, safety glasses, reflector type vests, protective gloves and safety footwear.

# TERMS & CONDITIONS

## CONQUIP ENGINEERING GROUP STANDARD PRODUCT WARRANTY

### 01. COMMENCEMENT

1.1 This Warranty shall commence on the Commencement Date and shall continue until the earlier of:

- (a) the Expiry Date; or
- (b) the date on which it may be voided in accordance with clause 4.1(b)

when it shall terminate automatically without notice.

### 02. DUTY OF GOOD FAITH

2.1 The Purchaser shall in the exercise of its rights under this Warranty and in the compliance with its obligations under this Warranty be subject to and shall in all respects owe and comply with a duty of good faith to the Warrantor.

### 03. NATURE AND EXTENT OF COVER

3.1 Subject to clause 3.2 the Warrantor agrees and undertakes to the Purchaser that it shall be liable to the Purchaser under and in accordance with the terms of this Warranty in the event that:

- (a) prior to the Expiry Date the Purchaser shall notify a Warranty Claim to the Warrantor; and
- (b) the Equipment or any relevant part of the Equipment shall have become unusable as the result of defective material or defective workmanship prior to the Expiry Date.

3.2 The Warrantor's obligation under clause 3.1 shall be expressly subject to the provisions of clauses 4, 5 and 6 and conditional upon the Purchaser's compliance in full with the provisions of clause 7.

### 04. RESTRICTIONS

4.1 The following restrictions apply to this Warranty:

(a) This Warranty is personal to the Purchaser and neither the legal benefit nor legal burden of this warranty may be assigned or novated or otherwise transferred by the Purchaser to any other party. Any purported assignment, novation or transfer shall not be binding upon the Warrantor.

(b) This Warranty shall be void in the event that the Purchaser:

(i) cannot provide authentic and original documentary evidence that the Purchaser has during the period between the Commencement Date and the Expiry Date complied with the Maintenance and Servicing Requirements; and/or

(ii) has, during the period between the Commencement Date and the Expiry Date, exceeded the Purchaser's Usage Cycle Parameters; and/or

(iii) has, during the period between the Commencement Date and the Expiry Date, exceeded the Purchaser's Use Parameters; and/or

(iv) has carried out, or procured the carrying out by any third party of, any repair to the Equipment or any part of the Equipment which is not an Authorised Repair; and/or

(v) has operated the Equipment after having replaced any part of the Equipment with a part which has not been supplied and fitted by the Warrantor; and/or

(vi) has modified the Equipment in any way prior to use.

### 05. EXCLUSIONS

5.1 The following are excluded from the scope of this Warranty:

(a) Loss of and/ or damage to the Equipment or any part of it resulting from any collision between the Equipment and any other fixed or stationary or mobile object whatsoever, irrespective of whether that collision was or was not caused by the Purchaser; and/or

(b) Loss of and/or damage to any personal property and/or possessions or other equipment not forming part of the Equipment but which is present in or about the Equipment; and/or

(c) loss and/or damage which is covered by any other insurance policy taken out and maintained by the Purchaser or in respect of which the Purchaser has a contractual obligation to do so; and/or

(d) loss and/or damage to the equipment which is consistent with the use by the Purchaser of the Equipment:

(i) in compliance with the Maintenance and Servicing Requirements; and

(ii) in compliance with the Usage Cycle Parameters; and

(iii) in compliance with the Use Parameters; and

(iv) having only carried out Authorised Repairs to the Equipment; and

(v) having all and any replacement parts fitted by the Warrantor; and

(vi) in unmodified form.

## 06. LIMITATION OF LIABILITY

6.1 The Warrantor's liability to the Purchaser shall be limited as follows:

- (a) The Warrantor shall not in any circumstances be liable to the Purchaser for indirect and/or consequential and/or economic loss suffered and/or incurred as the case may be by the Purchaser; and
- (b) The Warrantor shall only be liable to the Purchaser for the reasonable and proper costs reasonably and properly incurred by the Purchaser directly in connection with the repair and/or replacement (at the Warrantor's absolute discretion) of the Equipment or any part of the Equipment; and
- (c) The Warrantor's liability to the Purchaser shall notwithstanding any other provision of this Warranty, not in any circumstances exceed the Purchase Price of the Equipment.

## 07. WARRANTY CLAIMS

7.1 The Purchaser shall in respect of any claim against the Warrantor under this Warranty and within 24 hours of the occurrence of the subject matter of the Warranty Claim:

- (a) Complete in full and submit to the Warrantor a Warranty Claim in the form annexed to Schedule 4;
- (b) Provide date stamped or date identifiable photographs evidencing the claim; and
- (c) Make the Equipment or the relevant part of the Equipment available to the Warrantor for inspection within 48 hours of notification of the relevant Warranty Claim.

## 08. ENTIRE AGREEMENT

8.1 This Warranty constitutes the entire agreement between the parties and supersedes and extinguishes all previous promises, assurances, warranties, representations and understandings between them, whether written or oral, relating to its subject matter.

8.2 Each party agrees that it shall have no remedies in respect of any statement, representation, assurance or warranty (whether made innocently or negligently) that is not set out in this Warranty. Each party agrees that it shall have no claim for innocent or negligent misrepresentation or negligent misstatement based on any statement in this Warranty.

No variation of this Warranty shall be effective unless it is in writing and signed by the parties (or their authorised representatives).

## 09. WAIVER

No failure or delay by a party to exercise any right or remedy provided under this Warranty or by law shall constitute a waiver of that or any other right or remedy, nor shall it prevent or restrict the further exercise of that or any other right or remedy. No single or partial exercise of such right or remedy shall prevent or restrict the further exercise of that or any other right or remedy.

## 10. SEVERANCE

10.1 If any provision or part-provision of this Warranty is or becomes invalid, illegal or unenforceable, it shall be deemed deleted, but that shall not affect the validity and enforceability of the rest of this Warranty.

10.2 If any provision or part-provision of this Warranty is deemed deleted under clause 10.1 the parties shall negotiate in good faith to agree a replacement provision that, to the greatest extent possible, achieves the intended commercial result of the original provision.

## 11. THIRD PARTY RIGHTS

11.1 This Warranty does not give rise to any rights under the Contracts (Rights of Third Parties) Act 1999 to enforce any term of this Warranty.

## 12. GOVERNING LAW

12.1 This Warranty and any dispute or claim (including non-contractual disputes or claims) arising out of or in connection with it or its subject matter or formation shall be governed by and construed in accordance with the law of England and Wales.

## 13. JURISDICTION

13.1 Each party irrevocably agrees that the courts of England and Wales shall have exclusive jurisdiction to settle any dispute or claim (including non-contractual disputes or claims) arising out of or in connection with this Warranty or its subject matter or formation.

# EC DECLARATION OF CONFORMITY

## IN ACCORDANCE WITH EN ISO 17050-1:2004

Declaration: As defined by the Machinery Directive 2006/42/EC and subsequent amendments

We, CONQUIP ENGINEERING GROUP, herewith declare that the following indicated equipment meets the fundamental health and safety requirements concerning the EU guideline(s), due to their design and manufacture.

This declaration will be rendered null and void if the machine is changed without our approval.

**SIGNED:**

**DATED: 2024**

Garry Critchley, Chief Executive Officer

PRODUCT CODES	GENERAL DESCRIPTION / DESIGNATION	WORKING LOAD LIMIT
EA015AD-04000	Excavator Mechanical Pipe Lifter 4000	4000kg
EA015AE-06000	Excavator Mechanical Pipe Lifter 6000	6000kg

ITEM	CODE	DESCRIPTION
<b>EC DIRECTIVE/REGULATION</b>	2006/42/EC	Directive 2006/42/EC- new machinery directive
<b>HARMONISED STANDARDS</b>	BS EN ISO 12100:2010	Safety of machinery General principles for design Risk assessment and risk reduction
<b>OTHER REGULATIONS</b>	LOLER 1998	Lifting Operations and Lifting Equipment Regulations 1998 (LOLER)
	PUWER 1998	Provision and Use of Work Equipment Regulations 1998 (PUWER)

TALKING TO US IS EASY  
**WE'RE HERE TO HELP**

Call us on 0333 300 3470  
Email us at [sales@cqegroup.com](mailto:sales@cqegroup.com)  
[www.cqegroup.com](http://www.cqegroup.com)

