

User Guide

# Forklift Access Cage

---



## Product Information

# Overview

---

The Conquip Forklift Access Cage is a fork mounted access cage that is used often used to carry out routine maintenance, inspection and stock-taking.

### **Key Benefits**

- Proven and safe method of transporting personnel short distances.
- Internal harness attachment points.
- One full mesh height side for additional safety.
- Manufactured in the UK from quality British and EU steel.

# Product Information

## Specification

Item	Product Code
Forklift Access Cage	FA804AA-00240

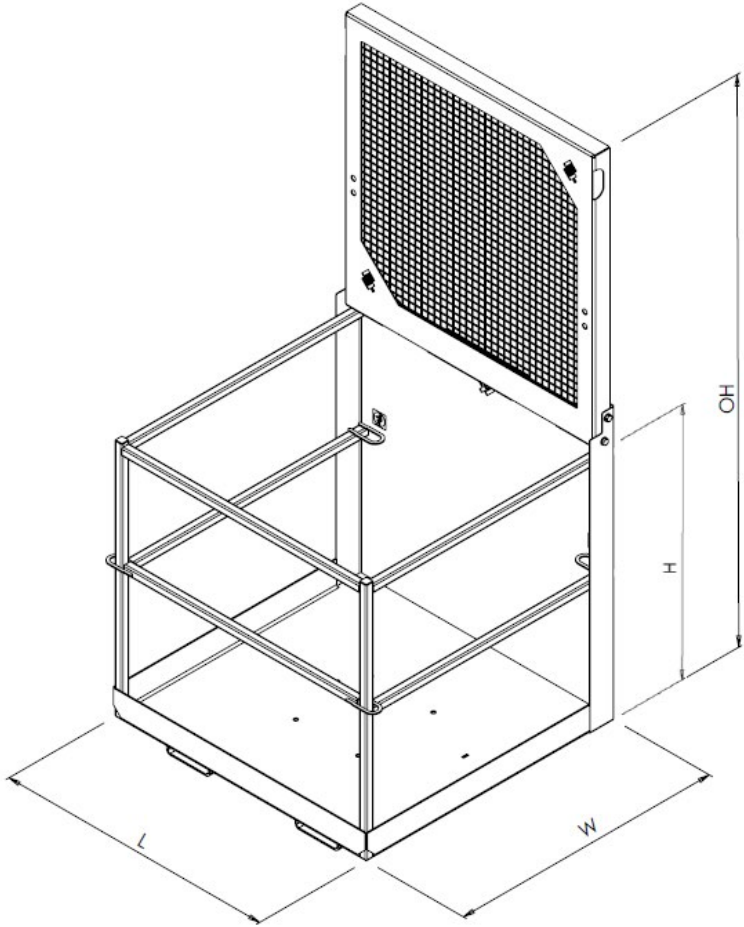

<sup>1</sup>Working Load Limit

Height (Open)	Height (Closed)	Width	Length	Weight	WLL <sup>1</sup>
2055mm	1167mm	1016mm	1093mm	140kg	250kg

# Original Working Instructions

## Usage Instructions

---

### Important Usage Notes

- This cage has been designed for a maximum of two people.
- Do not overload by volume or weight.
- This cage has been designed for working at height, not exiting at height. Do not exit from the cage unless it is positioned on ground level.
- Do not stand on the guardrails.
- Do not use boxes, steps or similar to gain extra height inside the cage.
- Do not place materials on to the platforms guardrails.
- Make sure all tools are tethered to relevant personnel or handrails.
- Do not use in high winds, storms, ice, snow, fog, sleet or other adverse weather conditions.
- Do not operate with other machinery simultaneously.
- Comply with harness manufacturer's usage instructions.

### Usage Instructions

1. Lift the mesh safety side up until fully vertical, and secure in place by ensuring it drops down into the catches.
2. To attach the Forklift Access Cage to a forklift, first release the heel pin by removing the lynch pin and pulling from the attachment. Set the machine's forks to the correct width for the Access Cage's fork pockets. Make sure that they are equidistant from the centre.
3. Drive the telehandler to the Forklift Access Cage aligning the forks with the Forklift Access Cage fork pockets.
4. Double check that all is correctly aligned, then move the telehandler forward until the forks are fully inserted into the fork pockets.
5. Apply the park brake and switch off the forklift engine.
6. Insert the heel pin ensuring it passes behind the heel of the fork, use the lynch pin to lock the heel pin in place. The Forklift Access Cage is now ready for use.
7. Personnel should enter the cage only when fully lowered.

# Original Working Instructions

## Usage Instructions

---

### Usage Instructions Continued

8. Attach a harness and restraint lanyard to the anchorage point. Ensure the length of the lanyard restricts access from the cage.
9. Slide the entry bar up, enter the cage, then allow the bar to drop back into position.
10. Do not allow more than two people to enter the cage.
11. Carefully raise the cage just off the ground and check for balance and security.
12. Carefully transport the cage to its required destination, taking care not to jolt the load.
13. While the cage is elevated the forklift operator must remain at the controls and the forklift must not be capable of movement, including tilt or side shift and chassis or mast levelling. The cage is not suitable for use on variable reach trucks that can lift to a nominal height greater than 6 metres, in accordance with PM28 fourth edition.
14. When you have finished with the cage, lower onto firm, level ground.
15. Having lowered the platform to the ground, exit and close the gate behind you. Do not exit the platform unless at ground level. Do not exit unless the cage is stationary and stable.
16. When you have finished with the cage, take it to its storage position, lower onto firm, level ground and remove from the forklift.

# Original Working Instructions

## Safety Instructions

---

### Basic Safety

A site-specific Risk Assessment, and lift plan where applicable, must be completed by the responsible person before using this equipment to control risks, produce a safe system of work and ensure safety for you, your colleagues and others. Your risk assessment will determine the correct Personal Protective Equipment (PPE) for the task you are doing. You must use it. Conquip recommends that you should wear:

- Suitable clothing
- Gloves
- Hard hat
- Protective footwear (steel toecaps)
- Safety glasses



### Important Safety Notes

- Read these instructions before using this equipment. If there is anything you do not understand or if you have any concerns do not use this equipment. Contact your supervisor or Conquip Engineering Group for advice.
- You must check that you have considered all the safety requirements for the task you are doing and that this equipment is suitable.
- You must protect bystanders and the general public by preventing access to the working area.
- Do not use this equipment if you are tired, unwell or under the influence of alcohol or drugs. If you are taking any medicine or undergoing treatment you should inform your supervisor.

## Usage & Transportation

- Never unevenly load this equipment.
- The weight of the equipment, together with its attachments, must be added to the weight of the load when calculating the total load that will be imposed on the lifting apparatus / operating machine.
- This equipment must be used in conjunction with the load ratings of the lifting apparatus / operating machine. (Refer to the manufacturers' load ratings and original working instructions).
- Make sure you know how to use this equipment and understand all aspects of its operation in case of emergency.
- This equipment weighs more than 25kg. Do not lift or manhandle without machine assistance.
- Do not operate this equipment near overhead power lines.
- Take care in confined spaces, near ceilings or similar hazards. This equipment was designed for vertical lifting. Do not drag, or swing.
- Before operating this equipment, check that you have enough space for you to work safely and make sure that the working area is clear of hazards, obstructions and personnel.
- Before lowering equipment make sure that the landing zone is clear and capable of accepting the size and weight of the load.
- Crush Risk. Keep hands and feet clear of the equipment at all times to avoid injury.
- Do not exceed the maximum Working Load Limit (WLL) shown on the serial plate. Ensure that the WLL on the individual lift points is not exceeded.
- Before lifting, check that the load is secured, balanced and stable. Allow space for the equipment to move if the load shifts.
- Manoeuvre loaded or raised equipment carefully. Travel and turn slowly to avoid unit becoming unstable.

## Personnel

- All personnel must wear relevant personal protective equipment.
- Do not wear loose clothing or jewellery and tie back long hair to avoid becoming tangled or trapped in this equipment. You must make everyone in the work area aware of what you are doing.
- All personnel involved in the lifting operation must be competent to do so and must have been briefed in conjunction with this User Guide available from Conquip Engineering Group, the manufacturer.

## Equipment Maintenance & Cleaning

- It is mandatory that the equipment is thoroughly examined regularly, by a qualified engineer, to ensure compliance with relevant regulation/s. (Conquip recommend to carry out thorough examination every six months).
- This product may incorporate various loose and detachable items of lifting gear. Refer to the separate requirements for the safe use of those items.
- When not being used, store the unit in a clean, upright condition and in a safe place where it will be protected from thieves and unauthorised users.
- This equipment must be inspected by the responsible person before each use and then regularly, as determined by your risk assessment or working practice. If you have any concerns about condition or suitability do not use.

# Disclaimer

---

## Warranty

The products supplied by Conquip Engineering Group are all guaranteed by a 12 month warranty.

Apart from where exceptions apply, Conquip Engineering Group promises to repair or replace any fault which the Company considers to be due to defective material or workmanship within 12 months of the date of sale, at no additional cost.

- Faults arising from unauthorised alterations (see modifications section below for full details).
- Damage caused by abuse, neglect, misuse or falling.
- Damage caused because of failure to follow transportation, storage, loading, cleaning or operating instructions.
- Replacement or repair of components due to fair wear and tear.
- Any consequential damage or wear arising from the use or fitting of additional or non-standard parts.

## Modifications

If any third-party modifications or alterations, involving drilling, welding, cutting or distortion of materials in any form, are to be carried out on the product, Conquip Engineering Group must provide full written approval prior to the work being carried out.

Alterations, modifications, additions or repairs must be carried out by Conquip Engineering Group's recognised distributors, if they are not carrying out the work themselves.

Conquip Engineering Group operate a continuous improvement policy and therefore reserve the right to alter technical specifications and user guide details at any point without notice.

Conquip Engineering Group will not cover or reimburse any transportation and/or shipment costs to and from their premises or their recognised agents, or any material and/or labour costs for repair, replacement or assessment against a warranty claim.

Conquip Engineering Group and/or their directors, employees, insurers or recognised agents will not be held liable for consequential damages, losses or expenses relating to the inability to use the product correctly for its purpose.



# EC Declaration of Conformity

---

## In accordance with EN ISO 17050-1:2004

Declaration: As defined by the Machinery Directive 2006/42/EC and subsequent amendments

We, CONQUIP ENGINEERING GROUP, herewith declare that the following indicated equipment meets the fundamental health and safety requirements concerning the EU guide line(s), due to their design and manufacture.

This declaration will be rendered null and void if the machine is changed without our approval.

**Signed:**



**Dated: 2018**

**Garry Critchley, Managing Director**

<b>Product Code(s):</b>	FA804AA-00240
<b>EC Directive/Regulation:</b>	2006/42/EC, Lifting Operations and Lifting Equipment Regulations 1998 Provision and Use of Work Equipment Regulations 1998
<b>Harmonised Standards:</b>	BS EN ISO 12100:2010
<b>General Description/Designation:</b>	Forklift Access Cage- FA804AA-00240
<b>WLL:</b>	FA804AA-00240 = 250kg



## Important Notes

- This User Guide is for this Conquip product only.
- Any movements of the product must be thoroughly planned before the work commences to identify potential hazards and assess risk.
- All personnel involved in lifting and transportation of this product must have read this User Guide and must be properly briefed.
- You must be competent, alert and medically fit when using this equipment. If you have a medical condition, a mental or physical disability, you must seek advice from a medical professional before using this equipment.

Talking to us is easy

**We're here to help**

Call us on 0845 520 1101

Email us at [sales@cqegroup.com](mailto:sales@cqegroup.com)

[www.cqegroup.com](http://www.cqegroup.com)

**Conquip Engineering Group**

Waterbrook Estate, Alton, Hampshire, GU34 2UD