

User Guide

Formwork Rack



Product Information

Overview

The Conquip Formwork Rack is a stillage for holding and separating stored goods, particularly designed for formwork and concrete shuttering panels. It has been manufactured to suit all types of concrete shuttering, including timber, steel, plastic and structural formwork components.

Key Benefits

- Large capacity for storing formwork panels and other concrete shuttering equipment.
- Can store formwork panels safely and allow efficient access to panels.
- Fitted with rubber stops at top of rack to ensure panels do not slide and are held firmly in place.
- Available in two sizes to accommodate for varying sizes of formwork.
- Manufactured in the UK from British and European steel.
- Can be forklifted into position using standard width fork pockets.

Product Information Specification

Item	Product Code
Formwork Rack	ST127AA-05400
Formwork Rack	ST127AB-05400

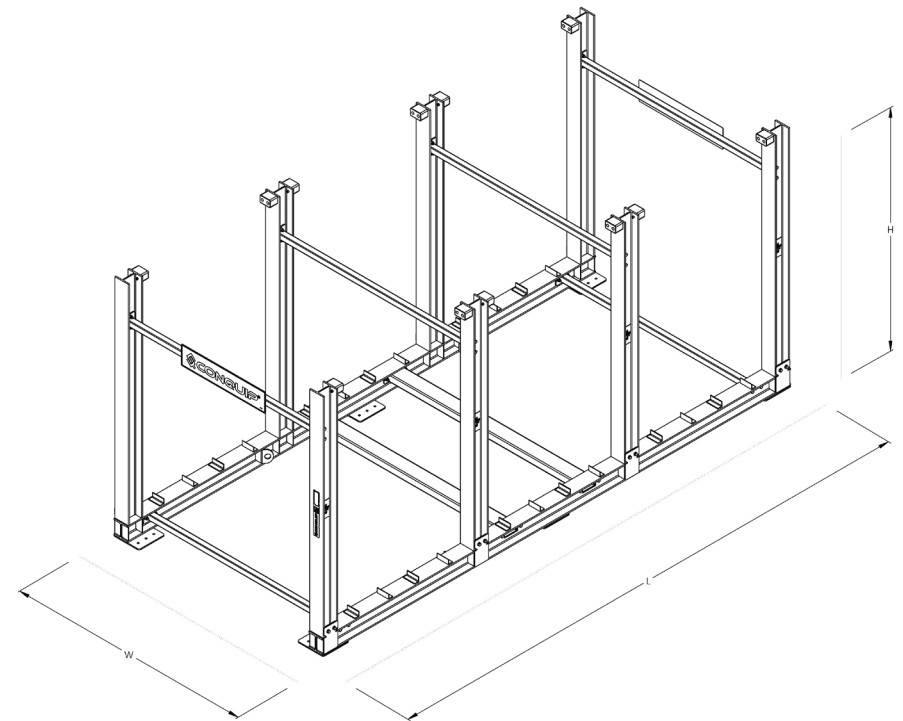

¹Working Load Limit

Product Code	Height	Width	Storage Bay Width	Length	Weight	Lifting Points
ST127AA-05400	2570mm	2420mm	1570mm	5400mm	1590kg	4
ST127AB-05400	2570mm	2420mm	1570mm	5400mm	1000kg	4

Product Information Parts Diagram

Formwork Rack

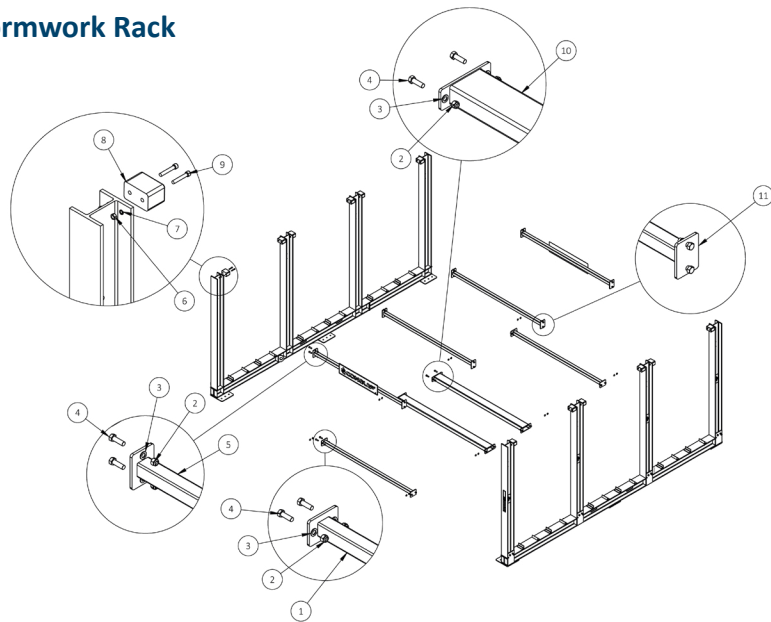

NOTE: These parts are for this model, they may differ for previous versions. Please contact Conquip with any queries.

Item Number	Part Number	Description	Quantity
1	ST127AA-05400-06	Lower Cross Beam Assembly	2
2	NS800121	M16 Nyloc Nut	32
3	NS800347	M16 Flat Washer	32
4	NS800646	M16x50 Hex Head Bolt 8.8	32
5	ST127AA-05400-08	Cross Beam Assembly	2
6	NS800542	M12 Full Nut	24
7	NS800887	M12 Spring Washer	24
8	ZZ990407	Rubber Buffer 120 x 75 x 80	12
9	NS800983	M12 x 70 Socket Cap Screw	24
10	ST127AA-05400-07	Fork Pocket Assembly	2
11	ST127AA-05400-04	Cross Beam Assembly	2

Product Information Parts Diagram

Formwork Rack

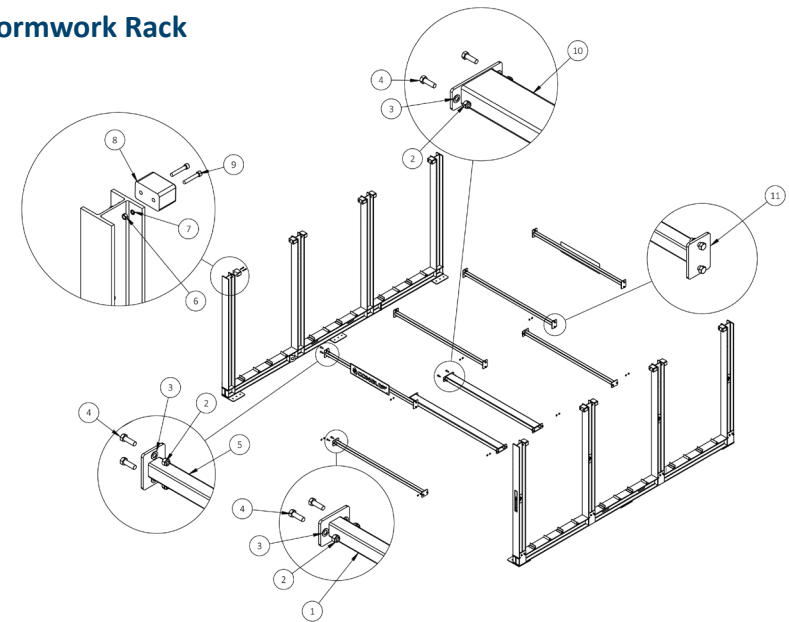

NOTE: These parts are for this model, they may differ for previous versions. Please contact Conquip with any queries.

Item Number	Part Number	Description	Quantity
1	ST127AB-05400-06	Lower Cross Beam Assembly	2
2	NS800121	M16 Nyloc Nut	32
3	NS800347	M16 Flat Washer	32
4	NS800646	M16x50 Hex Head Bolt 8.8	32
5	ST127AB-05400-08	Cross Beam Assembly	2
6	NS800542	M12 Full Nut	24
7	NS800887	M12 Spring Washer	24
8	ZZ990407	Rubber Buffer 120 x 75 x 80	12
9	NS800983	M12 x 70 Socket Cap Screw	24
10	ST127AB-05400-07	Fork Pocket Assembly	2
11	ST127AB-05400-04	Cross Beam Assembly	2

Original Working Instructions

Usage Instructions

Important Usage Notes

- Ensure that the ground is flat and free from obstacles, services or machinery. Make sure the lifting equipment or telehandler is suitably rated to carry the Formwork Rack.
- Depending on the weight, size and angle of the formwork panels, the horizontal loading will change. It is up to the customer to work out the forces of their formwork. Ensure that no more than 7.5kN is applied onto each upright (15kN Total) for the ST127AA-05400 and no more than 4kN is applied onto each upright (8kN Total) for the ST127AB-05400.
- Load rack evenly to prevent overturning. Conquip recommend bolting to the floor to aid stability.
- The Formwork Rack should not be lifted by any means other than the four lifting points or the integral fork pockets.
- Personnel must be cautious around the rack as large panels could be stored that exceed the size of the rack itself.
- Do not allow personnel near the Formwork Rack if you are using heavy machinery to load or unload shuttering and materials from the Formwork Rack.
- The Formwork Rack is only designed to be lifted when empty, DO NOT lift if it is being used to store materials.

Lifting with a Forklift

1. To lift the Formwork Rack with a forklift, set the machine's forks to the correct width for the Formwork Rack's fork pockets. Make sure that they are equidistant from the centre.
2. Drive the forklift to the Formwork Rack aligning the forks with the fork pockets.
3. Move the forklift forward until the forks are fully inserted into the fork pockets. The Formwork Rack is now ready to lift.
4. Carefully raise the rack just off the ground and check for balance and security.
5. Carefully transport the rack to its required destination, taking care not to jolt.
6. When in position, the rack can be lowered onto firm, level ground, free from obstruction.

Original Working Instructions

Usage Instructions

7. Reverse the forklift back and clear of the rack.

Lifting with a Crane

1. Attach a suitable four leg chain sling to the four Formwork Rack's lifting points.
2. Carefully raise the rack just off the ground and check for balance and security.
3. Carefully transport the rack to its required destination, taking care not to jolt.
4. When in position, the rack can be lowered on to firm, level ground, free from obstruction.

Usage Instructions

1. Load the formwork panels in either of the two middle sections of the Formwork Rack initially. Then work out to the sides, ensuring that the frame is evenly loaded. The height and width of the panels stored in the rack are to be assessed by the site.
2. The Formwork Rack can be used either freestanding or bolted down. However:-
 - If free standing, do not store panels leaning away from the centre. Load rack evenly to prevent overturning. Do not overload one side of the rack.
 - If bolted down, panels can be stored in any variation if there is no more than 15kN being applied to an upright for the ST127AA-05400 and 8kN for the ST127AB-05400.
3. When you have finished using the Formwork Rack for storage, unload the materials and equipment carefully.
4. Transport the Formwork Rack to new location using a suitable lifting equipment or telehandler.

Original Working Instructions

Usage Instructions

Maximum Lateral Force

The live load (A) acting on each upright on the formwork rack, as the formwork is placed into the rack, must not surpass the below:

Maximum Lateral Force at A = 7.5kN for ST127AA-05400, 4kN for ST127AB-05400.

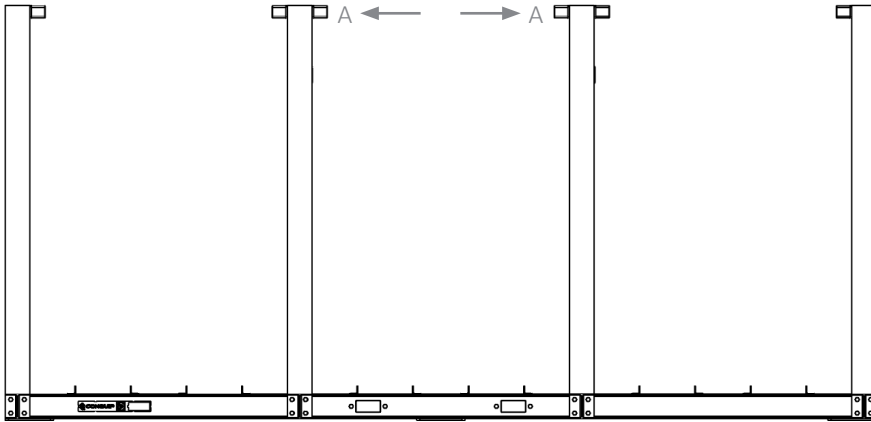

Original Working Instructions

Safety Instructions

Basic Safety

A site-specific Risk Assessment, and lift plan where applicable, must be completed by the responsible person before using this equipment to control risks, produce a safe system of work and ensure safety for you, your colleagues and others. Your risk assessment will determine the correct Personal Protective Equipment (PPE) for the task you are doing. You must use it. Conquip recommends that you should wear:

- Suitable clothing
- Gloves
- Hard hat
- Protective footwear (steel toe caps)
- Safety glasses



Important Safety Notes

- Read these instructions before using this equipment. If there is anything you do not understand or if you have any concerns do not use this equipment. Contact your supervisor or Conquip Engineering Group for advice.
- You must check that you have considered all the safety requirements for the task you are doing and that this equipment is suitable.
- You must protect bystanders and the general public by preventing access to the working area.
- Do not use this equipment if you are tired, unwell or under the influence of alcohol or drugs. If you are taking any medicine or undergoing treatment you should inform your supervisor.

Usage & Transportation

- Never unevenly load this equipment.
- The weight of the equipment, together with its attachments, must be added to the weight of the load when calculating the total load that will be imposed on the lifting apparatus / operating machine.
- This equipment must be used in conjunction with the load ratings of the lifting apparatus / operating machine. (Refer to the manufacturers' load ratings and original working instructions).
- Make sure you know how to use this equipment and understand all aspects of its operation in case of emergency.
- This equipment weighs more than 25kg. Do not lift or manhandle without machine assistance.
- Do not operate this equipment near overhead power lines.
- Take care in confined spaces, near ceilings or similar hazards. This equipment was designed for vertical lifting. Do not drag, or swing.
- Before operating this equipment, check that you have enough space for you to work safely and make sure that the working area is clear of hazards, obstructions and personnel.
- Before lowering equipment make sure that the landing zone is clear and capable of accepting the size and weight of the load.
- Crush Risk. Keep hands and feet clear of the equipment at all times to avoid injury.
- Do not exceed the maximum Working Load Limit (WLL) shown on the serial plate. Ensure that the WLL on the individual lift points is not exceeded.
- Before lifting, check that the load is secured, balanced and stable. Allow space for the equipment to move if the load shifts.
- Manoeuvre loaded or raised equipment carefully. Travel and turn slowly to avoid unit becoming unstable.

Personnel

- All personnel must wear relevant personal protective equipment.
- Do not wear loose clothing or jewellery and tie back long hair to avoid becoming tangled or trapped in this equipment. You must make everyone in the work area aware of what you are doing.
- All personnel involved in the lifting operation must be competent to do so and must have been briefed in conjunction with this User Guide available from Conquip Engineering Group, the manufacturer.

Equipment Maintenance & Cleaning

- It is mandatory that the equipment is thoroughly examined regularly, by a qualified engineer, to ensure compliance with relevant regulation/s. (Conquip recommend to carry out thorough examination every six months).
- This product may incorporate various loose and detachable items of lifting gear. Refer to the separate requirements for the safe use of those items.
- When not being used, store the unit in a clean, upright condition and in a safe place where it will be protected from thieves and unauthorised users.
- This equipment must be inspected by the responsible person before each use and then regularly, as determined by your risk assessment or working practice. If you have any concerns about condition or suitability do not use.

Disclaimer

Warranty

The products supplied by Conquip Engineering Group are all guaranteed by a 12 month warranty.

Apart from where exceptions apply, Conquip Engineering Group promises to repair or replace any fault which the Company considers to be due to defective material or workmanship within 12 months of the date of sale, at no additional cost.

- Faults arising from unauthorised alterations (see modifications section below for full details).
- Damage caused by abuse, neglect, misuse or falling.
- Damage caused because of failure to follow transportation, storage, loading, cleaning or operating instructions.
- Replacement or repair of components due to fair wear and tear.
- Any consequential damage or wear arising from the use or fitting of additional or non-standard parts.

Modifications

If any third-party modifications or alterations, involving drilling, welding, cutting or distortion of materials in any form, are to be carried out on the product, Conquip Engineering Group must provide full written approval prior to the work being carried out.

Alterations, modifications, additions or repairs must be carried out by Conquip Engineering Group's recognised distributors, if they are not carrying out the work themselves.

Conquip Engineering Group operate a continuous improvement policy and therefore reserve the right to alter technical specifications and user guide details at any point without notice.

Conquip Engineering Group will not cover or reimburse any transportation and/or shipment costs to and from their premises or their recognised agents, or any material and/or labour costs for repair, replacement or assessment against a warranty claim.

Conquip Engineering Group and/or their directors, employees, insurers or recognised agents will not be held liable for consequential damages, losses or expenses relating to the inability to use the product correctly for its purpose.

EC Declaration of Conformity

In accordance with EN ISO 17050-1:2004

Declaration: As defined by the Machinery Directive 2006/42/EC and subsequent amendments

We, CONQUIP ENGINEERING GROUP, herewith declare that the following indicated equipment meets the fundamental health and safety requirements concerning the EU guide line(s), due to their design and manufacture.

This declaration will be rendered null and void if the machine is changed without our approval.

Signed:



Dated: 2022

Garry Critchley, Managing Director

Product Code(s):	ST127AA-05400 / ST127AB-05400
EC Directive/ Regulation:	2006/42/EC, Lifting Operations and Lifting Equipment Regulations 1998 Provision and Use of Work Equipment Regulations 1998
Harmonised Standards:	BS EN ISO 12100:2010
General Description/ Designation:	Formwork Rack – ST127AA-05400 / ST127AB-05400
WLL:	ST127AA-05400 / ST127AB-05400 = Self Weight

Important Notes

- This User Guide is for this Conquip product only.
- Any movements of the product must be thoroughly planned before the work commences to identify potential hazards and assess risk.
- All personnel involved in lifting and transportation of this product must have read this User Guide and must be properly briefed.
- You must be competent, alert and medically fit when using this equipment. If you have a medical condition, a mental or physical disability, you must seek advice from a medical professional before using this equipment.

Talking to us is easy

We're here to help

Call us on 0845 520 1101

Email us at sales@cqegroup.com

www.cqegroup.com

Conquip Engineering Group

Waterbrook Estate, Alton, Hampshire, GU34 2UD