

Long Load Trolley



Introduction

The Conquip Long Load Trolley is a support trolley designed to assist the slinging and transportation of heavy and awkward materials, such as formwork and steelwork, from a loading platform into and out of structure and can be used to transport loads around a concrete slab or floor structure.

It allows loads that are longer than the deck of the CantiDeck platform to be safely slung and lifted away without needing to open the doors at the leading edge of a platform.

Key Benefits

- Increases safety and best practice on site when working with CantiDeck loading platforms.
- High Working Load Limit at 1500kg.
- Robust steel framework with removable side extensions for ease of loading.
- Increases the ease of moving heavy and awkward loads around a structure.

Important Notes

- This User Guide is for this Conquip product only.
- Any movements of the product must be thoroughly planned before the work commences to identify potential hazards and assess risk.
- All personnel involved in lifting and transportation of this product must have read this User Guide and must be properly briefed.
- You must be competent, alert and medically fit when using this equipment. If you have a medical condition, a mental or physical disability, you must seek advice from a medical professional before using this equipment.

Long Load Trolley Specification

LONG LOAD TROLLEY - LLST

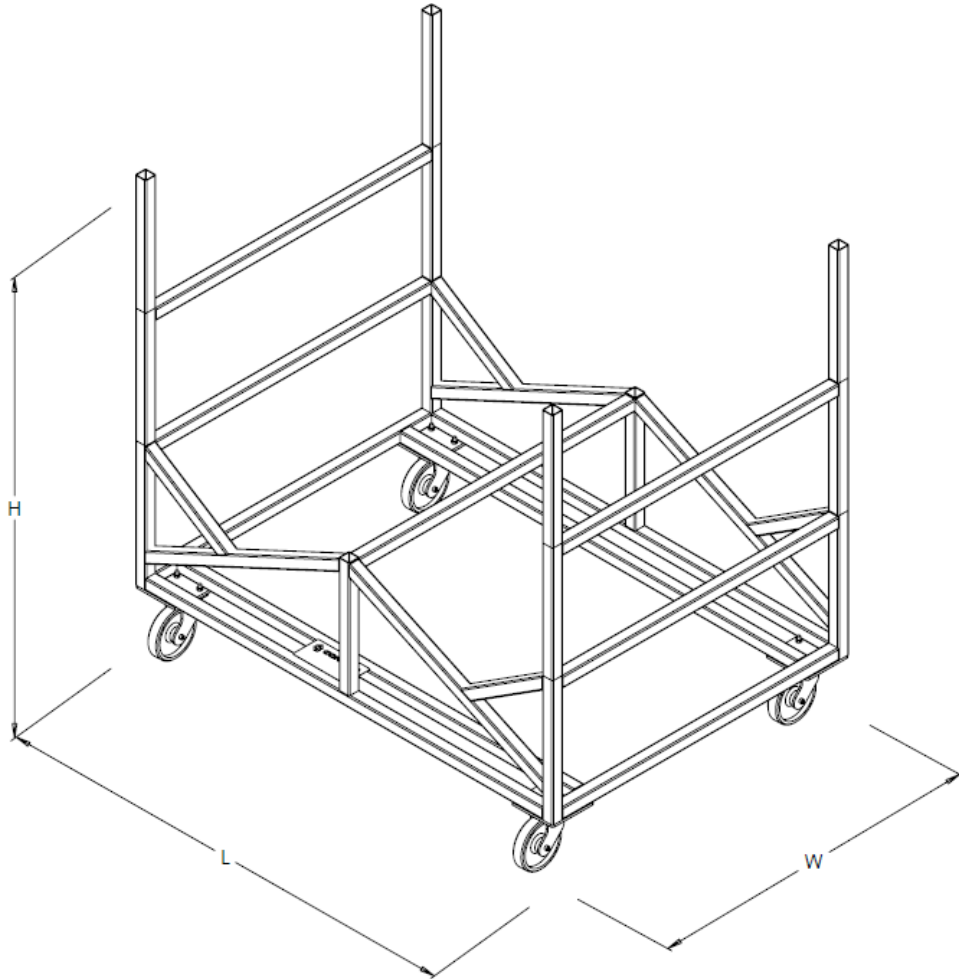

Height	Load Height	Length	Width	WLL ¹	Weight
1960mm	1400mm	2000mm	1420mm	1500kg	160kg

¹ Working Load Limit

Long Load Trolley Specification

LONG LOAD TROLLEY PARTS DIAGRAM - LLST

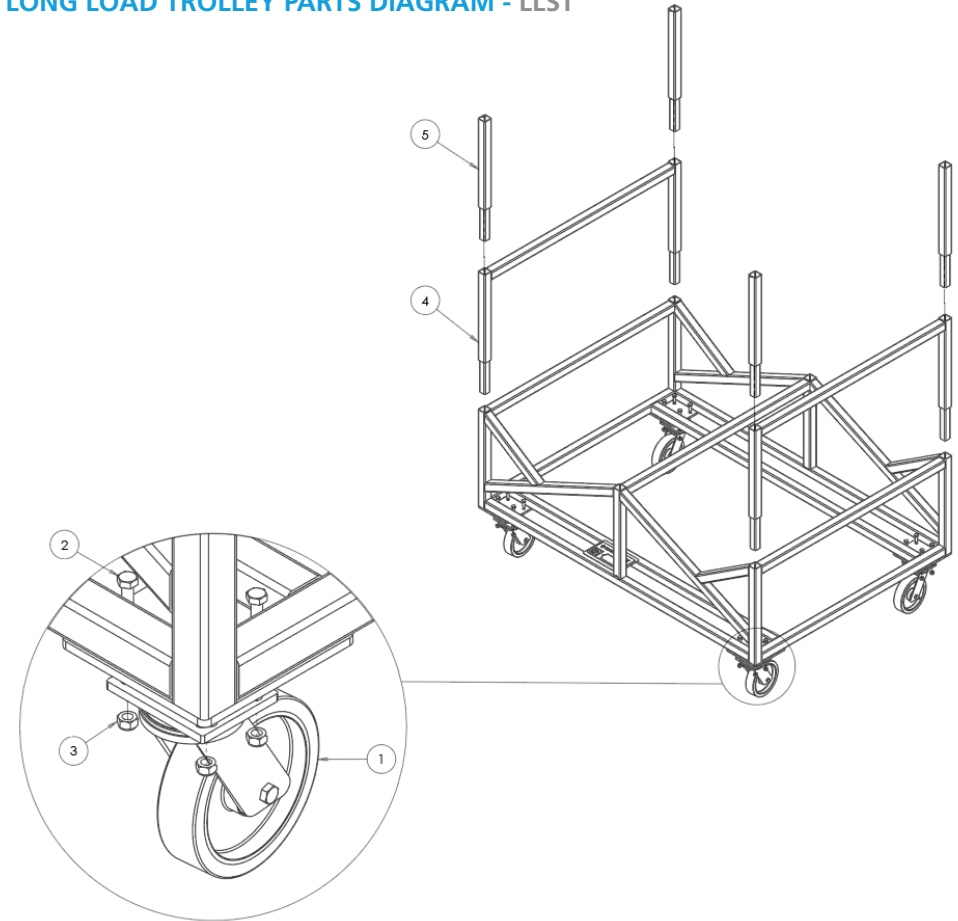

Item Number	Part Number	Description	Quantity
1	ZZ220010	200mm Swivel Castor	4
2	NS800889	M12 x 40 Hex Head Bolt	16
3	NS8000015	M12 Nyloc Nut	16
4	LLST-03	Extension Brace	2
5	LLST-02	Extension Tube	4

NOTE: These parts are for this model, they may differ for previous versions. Please contact Conquip with any queries.

Original Working Instructions

USAGE INSTRUCTIONS

1. Manoeuvre the Long Load Trolley to the load to be transported.
2. If necessary remove the two side extensions from the side of the trolley nearest the load, by pulling them out vertically, to assist loading.
3. Load the materials onto the trolley evenly.
4. If necessary replace the two side extensions, ensuring they are fully inserted into the framework, to prevent the load from slipping.
5. Arrange the load close together on the trolley and securely fasten with a suitable straps.
6. Attach tag lines to the load to aid manoeuvring when lifted off the trolley.
7. Roll the trolley onto the deck.
8. Attach suitable lifting apparatus to the load.
9. Carefully lift the load off the trolley, directing it away from the building with the tag lines.
10. Once the trolley is free of the load it can be rolled back into the structure of the building, or used in the same way to load with materials being crane lifted into the building.

Important Usage Instructions Notes

- Always move the trolley with more than one person when loaded, do not attempt to move the trolley on your own.
- When stationary choke the wheels.
- Do not use on an incline.

Original Working Instructions

BASIC SAFETY

A site-specific **Risk Assessment**, and **lift plan** where applicable, must be completed by the responsible person before using this equipment to control risks, produce a safe system of work and ensure safety for you, your colleagues and others. Your risk assessment will determine the correct Personal Protective Equipment (PPE) for the task you are doing. You **must** use it.

Conquip recommends that you should wear:

- Suitable clothing
- Gloves
- Hard hat
- Protective footwear (steel toecaps)
- Safety glasses



Important Safety Instruction Notes

- Read these instructions before using this equipment. If there is anything you do not understand or if you have any concerns do not use this equipment. Contact your supervisor or Conquip Engineering Group for advice.
- You must check that you have considered all the safety requirements for the task you are doing and that this equipment is suitable.
- You must protect bystanders and the general public by preventing access to the working area.
- Do not use this equipment if you are tired, unwell or under the influence of alcohol or drugs. If you are taking any medicine or undergoing treatment you should inform your supervisor.

Safety Instructions

USAGE & TRANSPORTATION

- Never unevenly load this equipment.
- This equipment must be used in conjunction with the load ratings of the lifting apparatus / operating machine. (Refer to the manufacturers' load ratings and original working instructions).
- Make sure you know how to use this equipment and understand all aspects of its operation in case of emergency.
- This equipment weighs more than 25kg. Do not lift or manhandle without machine assistance.
- Do not operate this equipment near overhead power lines.
- Before operating this equipment, check that you have enough space for you to work safely and make sure that the working area is clear of hazards, obstructions and personnel.
- Crush Risk. Keep hands and feet clear of the equipment at all times to avoid injury.
- Do not exceed the maximum Working Load Limit (WLL) shown on the serial plate. Ensure that the WLL on the individual lift points is not exceeded.
- Before moving, check that the load is secured, balanced and stable. Allow space for the equipment to move if the load shifts.

Safety Instructions

PERSONNEL

- All personnel must wear relevant personal protective equipment.
- **Do not** wear loose clothing or jewellery and tie back long hair to avoid becoming tangled or trapped in this equipment. You must make **everyone** in the work area aware of what you are doing.
- All personnel involved in the lifting operation must be competent to do so and must have been briefed in conjunction with this User Guide available from Conquip Engineering Group, the manufacturer.

EQUIPMENT MAINTENANCE & CLEANING

- It is mandatory that the equipment is thoroughly examined regularly, by a qualified engineer, to ensure compliance with relevant regulation/s. (Conquip recommend to carry out thorough examination every six months).
- This product may incorporate various loose and detachable items of lifting gear. Refer to the separate requirements for the safe use of those items.
- When not being used, store the unit in a clean, upright condition and in a safe place where it will be protected from thieves and unauthorised users.
- This equipment must be inspected by the responsible person before each use and then regularly, as determined by your risk assessment or working practice. If you have any concerns about condition or suitability **do not use**.

Disclaimer

WARRANTY

The products supplied by Conquip Engineering Group are all guaranteed by a 12 month warranty.

Apart from where exceptions apply, Conquip Engineering Group promises to repair or replace any fault which the Company considers to be due to defective material or workmanship within 12 months of the date of sale, at no additional cost.

- Faults arising from unauthorised alterations (see modifications section below for full details).
- Damage caused by abuse, neglect, misuse or falling.
- Damage caused because of failure to follow transportation, storage, loading, cleaning or operating instructions.
- Replacement or repair of components due to fair wear and tear.
- Any consequential damage or wear arising from the use or fitting of additional or non-standard parts.

MODIFICATIONS

If any third-party modifications or alterations, involving drilling, welding, cutting or distortion of materials in any form, are to be carried out on the product, Conquip Engineering Group must provide full written approval prior to the work being carried out.

Alterations, modifications, additions or repairs must be carried out by Conquip Engineering Group's recognised distributors, if they are not carrying out the work themselves.

Conquip Engineering Group operate a continuous improvement policy and therefore reserve the right to alter technical specifications and user guide details at any point without notice.

Conquip Engineering Group will not cover or reimburse any transportation and/or shipment costs to and from their premises or their recognised agents, or any material and/or labour costs for repair, replacement or assessment against a warranty claim. Conquip Engineering Group and/or their directors, employees, insurers or recognised agents will not be held liable for consequential damages, losses or expenses relating to the inability to use the product correctly for its purpose.

[User Guide - Long Load Trolley](#)

EC Declaration of Conformity

IN ACCORDANCE WITH EN ISO 17050-1:2004

Declaration: As defined by the Machinery Directive 2006/42/EC and subsequent amendments

We; CONQUIP ENGINEERING GROUP

Herewith declare that the following indicated equipment meets the fundamental health and safety requirements concerning the EU guide line(s), due to their design and manufacture.

This declaration will be rendered null and void if the machine is changed without our approval.

SIGNED: _____ **DATE:** 2018

Garry Critchley, Managing Director

Product Code(s):	LLST
EC Directive/Regulation:	2006/42/EC, Provision and Use of Work Equipment Regulations 1998
Harmonised Standards:	BS EN ISO 12100:2010
General Description/Designation:	Long Load Trolley - LLST
WLL:	LLST = 1500kg

Conquip Engineering Group

Waterbrook Estate, Alton, Hampshire, GU34 2UD

T: 0845 520 1101

E: sales@cqegroup.com

W: www.cqegroup.com