

User Guide

IBC Lifting Frame



Product Information

Overview

A lifting frame for crane lifting Intermediate Bulk Containers (IBC).

It is designed for a 4-point lift and can easily facilitate moving water and other liquids around site for use in different locations.

Featuring a removable stabilising bar that can be attached to the side of the frame during loading and unloading. This hugely improves the safety of the IBC Lifting Frame by eliminating the risk of the bar causing injury.

Typical uses can include carrying water to the top floor of a concrete slab for spraying down the slab during the curing process, for a wet-curing method.

Key Benefits

- Complete with crane lifting points and fork pockets for easy manoeuvrability.
- Removable stabilising bar allows for easy placement of the toilet into the frame.
- Stabilising bar can be stowed on the side of the frame during loading and unloading.
- Latching chain provides extra security.
- Manufactured in the UK from quality British and EU steel.

Product Information

Specification

Item	Product Code
IBC Lifting Frame	CA148AA-01000

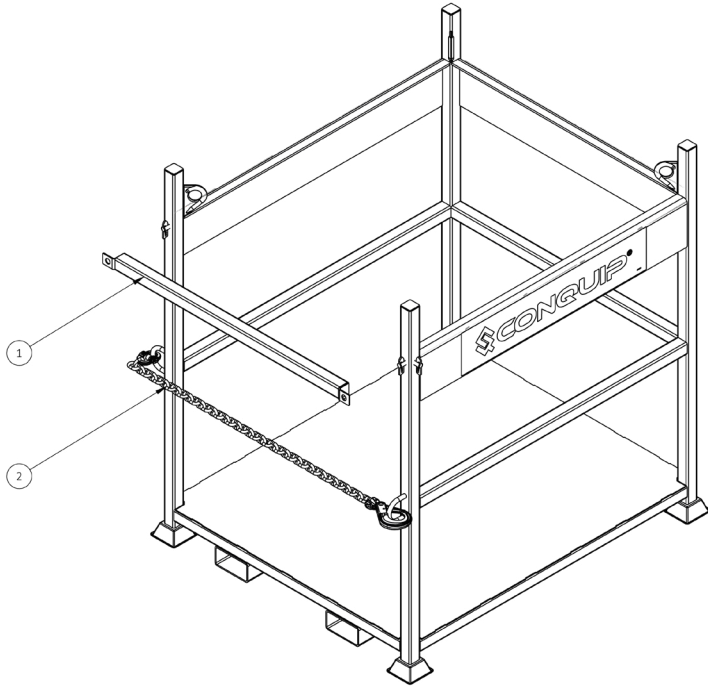

¹Working Load Limit

Product Code	Height	Width	Length	Weight	WLL ¹
CA148AA-01000	1550mm	1270mm	1470mm	250kg	1500kg

Product Code	Internal Height	Internal Width	Internal Length
CA148AA-01000	1210mm	1110mm	1310mm

Product Information

Parts Diagram

IBC Lifting Frame

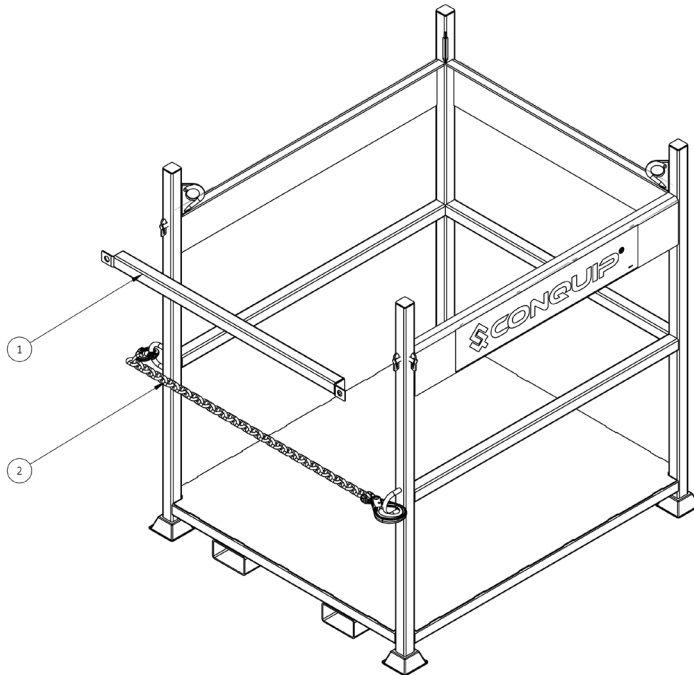

NOTE: These parts are for this model, they may differ for previous versions. Please contact Conquip with any queries.

Item Number	Part Number	Description	Quantity
1	CA148AA-01000-05	Removable Stabilising Bar	1
2	CO1.2-10-1ZA8	Chain Arrangement	1

Original Working Instructions

Usage Instructions

Important Usage Notes

- The IBC Lifting Frame is for lifting and transporting IBCs only. Do not use to raise or transport personnel.

Loading the Lifting Frame

1. To load the IBC Lifting Frame, remove the stabilising bar and attach the side of the frame the using anti-lock fasteners. Unlatch the chain and leave to one side.
2. Load the IBC onto the frame.
3. Replace the stabilising bar, ensuring that the bar is fully engaged with the set screw.
4. Also reconnect the chain across the opening.

Lifting with a Crane

1. Attach the lifting equipment's hook to the IBC Lifting Frame lifting point. Always ensure that the hook's gate is correctly closed and the lifting eye is seated correctly in the hook.
2. Carefully raise the frame just off the ground and check for balance and security.
3. Carefully transport the frame to its required destination, taking care not to jolt the load.
4. When in position, the frame can be lowered on to firm, level ground.
5. Unload the IBC from the frame, by removing the stabilising bar and stowing it on the side of the frame. Lift the IBC free from the frame.
6. Replace the stabilising bar and attach the chain.
7. When you have finished with the lifting frame, detach it from the lifting equipment.

Original Working Instructions

Usage Instructions

Lifting with a Forklift

1. Drive the telehandler to the IBC Lifting Frame aligning the forks with the IBC Lifting Frame fork pockets.
2. Double check that all is correctly aligned, then move the telehandler forward until the forks are fully inserted into the fork pockets.
3. Apply the park brake and switch off the forklift engine.
4. Insert the heel pin ensuring it passes behind the heel of the fork, use the lynch pin to lock the heel pin in place. The IBC Lifting Frame is now ready for use.
5. Carefully raise the frame just off the ground and check for balance and security.
6. Carefully transport the frame to its required destination, taking care not to jolt the load.
7. When in position, the frame can be lowered onto firm, level ground.
8. Remove the heel and lynch pins.
9. Reverse the forklift back and clear of the frame.
10. Replace the heel pins and lynch pins.
11. Unload the IBC from the frame, by removing the stabilising bar and stowing it on the side of the frame. Lift the IBC free from the frame.
12. Replace the stabilising bar and attach the chain.

Original Working Instructions

Safety Instructions

Basic Safety

A site-specific Risk Assessment, and lift plan where applicable, must be completed by the responsible person before using this equipment to control risks, produce a safe system of work and ensure safety for you, your colleagues and others. Your risk assessment will determine the correct Personal Protective Equipment (PPE) for the task you are doing. You must use it. Conquip recommends that you should wear:

- Suitable clothing
- Gloves
- Hard hat
- Protective footwear (steel toecaps)
- Safety glasses



Important Safety Notes

- Read these instructions before using this equipment. If there is anything you do not understand or if you have any concerns do not use this equipment. Contact your supervisor or Conquip Engineering Group for advice.
- You must check that you have considered all the safety requirements for the task you are doing and that this equipment is suitable.
- You must protect bystanders and the general public by preventing access to the working area.
- Do not use this equipment if you are tired, unwell or under the influence of alcohol or drugs. If you are taking any medicine or undergoing treatment you should inform your supervisor.

Usage & Transportation

- Never unevenly load this equipment.
- The weight of the equipment, together with its attachments, must be added to the weight of the load when calculating the total load that will be imposed on the lifting apparatus / operating machine.
- This equipment must be used in conjunction with the load ratings of the lifting apparatus / operating machine. (Refer to the manufacturers' load ratings and original working instructions).
- Make sure you know how to use this equipment and understand all aspects of its operation in case of emergency.
- This equipment weighs more than 25kg. Do not lift or manhandle without machine assistance.
- Do not operate this equipment near overhead power lines.
- Take care in confined spaces, near ceilings or similar hazards. This equipment was designed for vertical lifting. Do not drag, or swing.
- Before operating this equipment, check that you have enough space for you to work safely and make sure that the working area is clear of hazards, obstructions and personnel.
- Before lowering equipment make sure that the landing zone is clear and capable of accepting the size and weight of the load.
- Crush Risk. Keep hands and feet clear of the equipment at all times to avoid injury.
- Do not exceed the maximum Working Load Limit (WLL) shown on the serial plate. Ensure that the WLL on the individual lift points is not exceeded.
- Before lifting, check that the load is secured, balanced and stable. Allow space for the equipment to move if the load shifts.

Personnel

- All personnel must wear relevant personal protective equipment.
- Do not wear loose clothing or jewellery and tie back long hair to avoid becoming tangled or trapped in this equipment. You must make everyone in the work area aware of what you are doing.
- All personnel involved in the lifting operation must be competent to do so and must have been briefed in conjunction with this User Guide available from Conquip Engineering Group, the manufacturer.

Equipment Maintenance & Cleaning

- It is mandatory that the equipment is thoroughly examined regularly, by a qualified engineer, to ensure compliance with relevant regulation/s. (Conquip recommend to carry out thorough examination every six months).
- This product may incorporate various loose and detachable items of lifting gear. Refer to the separate requirements for the safe use of those items.
- When not being used, store the unit in a clean, upright condition and in a safe place where it will be protected from thieves and unauthorised users.
- This equipment must be inspected by the responsible person before each use and then regularly, as determined by your risk assessment or working practice. If you have any concerns about condition or suitability do not use.

Disclaimer

Warranty

The products supplied by Conquip Engineering Group are all guaranteed by a 12 month warranty.

Apart from where exceptions apply, Conquip Engineering Group promises to repair or replace any fault which the Company considers to be due to defective material or workmanship within 12 months of the date of sale, at no additional cost.

- Faults arising from unauthorised alterations (see modifications section below for full details).
- Damage caused by abuse, neglect, misuse or falling.
- Damage caused because of failure to follow transportation, storage, loading, cleaning or operating instructions.
- Replacement or repair of components due to fair wear and tear.
- Any consequential damage or wear arising from the use or fitting of additional or non-standard parts.

Modifications

If any third-party modifications or alterations, involving drilling, welding, cutting or distortion of materials in any form, are to be carried out on the product, Conquip Engineering Group must provide full written approval prior to the work being carried out.

Alterations, modifications, additions or repairs must be carried out by Conquip Engineering Group's recognised distributors, if they are not carrying out the work themselves.

Conquip Engineering Group operate a continuous improvement policy and therefore reserve the right to alter technical specifications and user guide details at any point without notice.

Conquip Engineering Group will not cover or reimburse any transportation and/or shipment costs to and from their premises or their recognised agents, or any material and/or labour costs for repair, replacement or assessment against a warranty claim.

Conquip Engineering Group and/or their directors, employees, insurers or recognised agents will not be held liable for consequential damages, losses or expenses relating to the inability to use the product correctly for its purpose.

Important Notes

- This User Guide is for this Conquip product only.
- Any movements of the product must be thoroughly planned before the work commences to identify potential hazards and assess risk.
- All personnel involved in lifting and transportation of this product must have read this User Guide and must be properly briefed.
- You must be competent, alert and medically fit when using this equipment. If you have a medical condition, a mental or physical disability, you must seek advice from a medical professional before using this equipment.

Talking to us is easy

We're here to help

Call us on 0800 116 076

Email us at sales@conquipgroup.co.nz

www.conquipgroup.co.nz