

USER GUIDE

DIRECT-TO-TRUCK BULKX

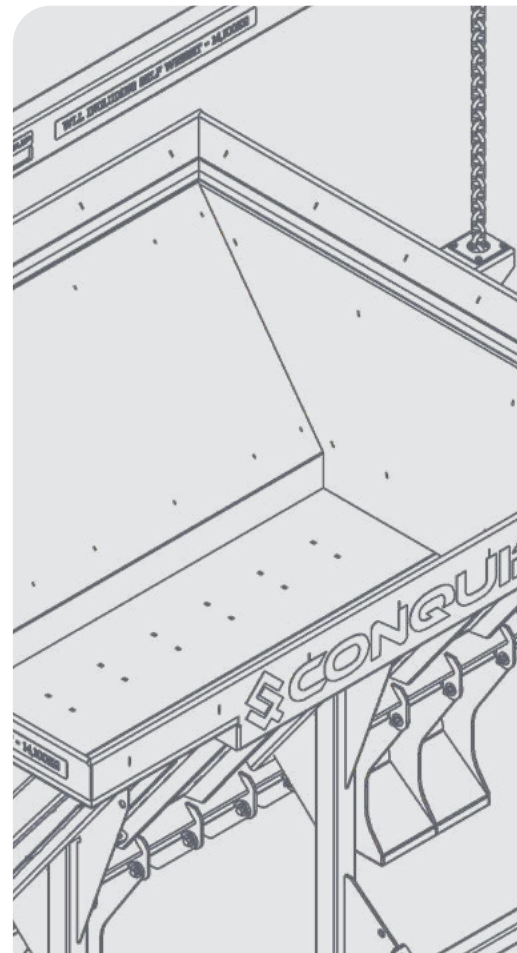

DISCLAIMER

Do not attempt to handle or operate this equipment before you have received sufficient training. Before use, operatives must have carried out all checks featured on the Visual Inspection Sheet on page 15. It is imperative that you have read the General Safety Instructions on page 16 and sufficiently familiarised yourself with the Operational Procedures in this document.

Note that this item is compliant only to the standards specified in this User Guide and it is therefore the duty of the responsible person(s) to review and ensure compliance.

CONTENTS

PRODUCT INFORMATION

INTRODUCTION	04
SPECIFICATION	06

OPERATIONAL PROCEDURES

IMPORTANT USAGE NOTES	08
BASIC OVERVIEW	08
PREOPERATIONAL TEST CYCLE	08
ASSEMBLY INSTRUCTIONS	09
LOADING THE BIN	11
MOVING & EMPTYING PROCEDURE	12

MAINTENANCE & INSPECTION

MAINTENANCE REGIME	14
VISUAL INSPECTION SHEET	15

GENERAL SAFETY INSTRUCTIONS

SAFETY INSTRUCTIONS	16
GENERAL NOTES	17

LEGAL

TERMS AND CONDITIONS	18
EC DESIGN CONFORMITY	22
STANDARDS AND REGULATIONS APPLICABLE	23

INTRODUCTION

OVERVIEW

Built with safety, efficiency and sustainability as priorities, the BulkX range is the ideal solution for the transportation of earth (muck) from an excavation zone.

The [Direct-To-Truck BulkX](#) is perfect for rapid muck away, particularly on inner-city projects where space is restricted, as no gantry or frame is required to land the drop-bottom bin for discharge. Instead, the bin empties directly into the back of a truck once the feet are landed on the sides and the spreader beam is lowered to activate the bottom doors.

Available in sizes from 3,000 to 8,000 litres, the Direct-To-Truck BulkX range eliminates double handling and maximises cycle efficiency, speeding up excavation and reducing the length of a project's dig programme.



KEY BENEFITS

MAXIMISES SITE SPACE

Ideal for sites with a limited footprint, the Direct-To-Truck BulkX does not require a muck bay, saving valuable working space. Trucks can even be loaded outside the site on the side of the road.

ELIMINATES SPOIL DOUBLE HANDLING

The bin is filled at the excavation location and emptied directly into the back of the muck away truck. No need to store spoil in muck bays or stockpiles on-site.

NO GANTRY OR LANDING FRAME

Sites save on the cost for additional steelwork and logistics are improved as the discharge area is not restricted to one location, so there is no downtime if the gantry needs to be repositioned during the project. The load is simply emptied when the operator lands the BulkX feet on the edges of the truck and lowers the spreader beam.

INCREASES PRODUCTIVITY

Using this method for bulk excavation can have a huge impact on reducing the length of dig programmes as the spoil is removed from site in one operation.

IMPROVES SAFETY

No operatives are required in the discharge zone, unlike some alternative methods. Plus, the load is contained within the bin, reducing the chance of loose material falling and injuring site personnel or the general public.

SPECIFICATION

THE RANGE



CODE	TYPE	WEIGHT (kg)	WLL* (kg)	CAPACITY (litres)
CA525-03000	Direct-To-Truck 3000	1350	6000	3000
CA525-04000	Direct-To-Truck 4000	1620	8000	4000
CA525-06000	Direct-To-Truck 6000	2090	12000	6000
CA525-08000	Direct-To-Truck 8000	2330	16000	8000

*Working Load Limit

SPECIFICATION

ITEM	PRODUCT CODE
Direct-To-Truck 3000	CA525-03000
Direct-To-Truck 4000	CA525-04000
Direct-To-Truck 6000	CA525-06000
Direct-To-Truck 8000	CA525-08000

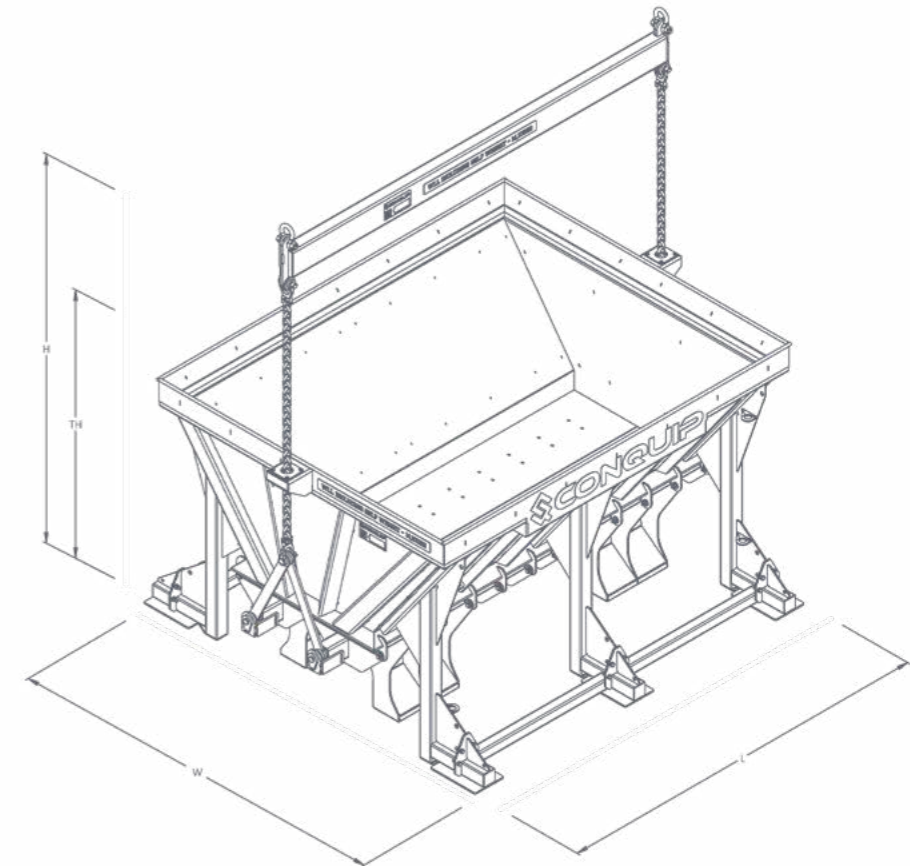

LENGTH (mm)	WIDTH (mm)	LIFTING HEIGHT (mm)	TRANSPORT HEIGHT (mm)
2806	2880	2930	1700
2820	2700	3020	1890
3440	2890	3650	1890
3400	2890	3980	2180

OPERATIONAL PROCEDURES

IMPORTANT USAGE NOTES

- DO NOT overload the bin by volume or by weight. The load should be evenly placed in the bin by weight and volume. If the bin is unevenly loaded when docking with the truck, it could result in damage to the truck.
- Where possible, two taglines with two operators on the ground should guide the bin to the optimum position.
- Approximately only 25% of the load is ever sat on the truck body as the load starts to discharge, the rest is held on the crane hook. If there are any concerns about wear and tear on the truck body, rubber or hardwood can be fitted to the feet of the bin for protection.

BASIC OVERVIEW

BulkX is a system generally comprising of a landing frame in a designated discharge area and one or more large drop bottom bins. This variation of BulkX does not require a landing frame, but instead relies on the back of the truck for discharge, and therefore discharges directly into the back of the truck.

When the 'feet' engage with the truck, the crane operator lowers the lifting chains, prompting the doors to open and the bin to discharge.

PREOPERATIONAL TEST CYCLE

To ensure that both the slinger or signaller and the crane operator are familiar with the correct and safe operation, it is advisable to have at least one test run with the unit empty. This will ensure that both fully understand how the system functions.

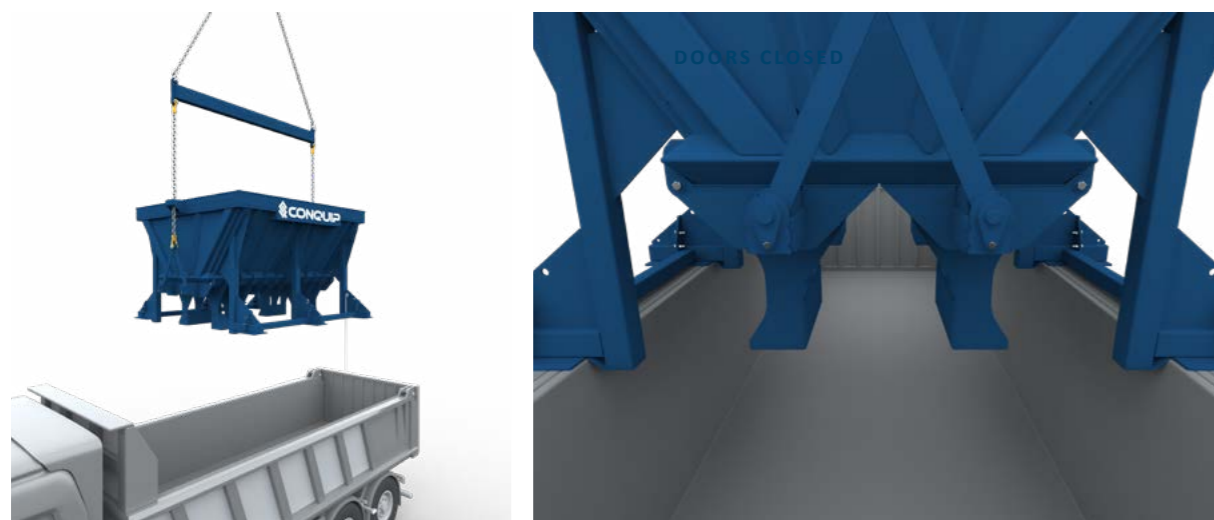

ASSEMBLY INSTRUCTIONS

01. Align the leg extension assembly with the leg extension bracket on the unit.

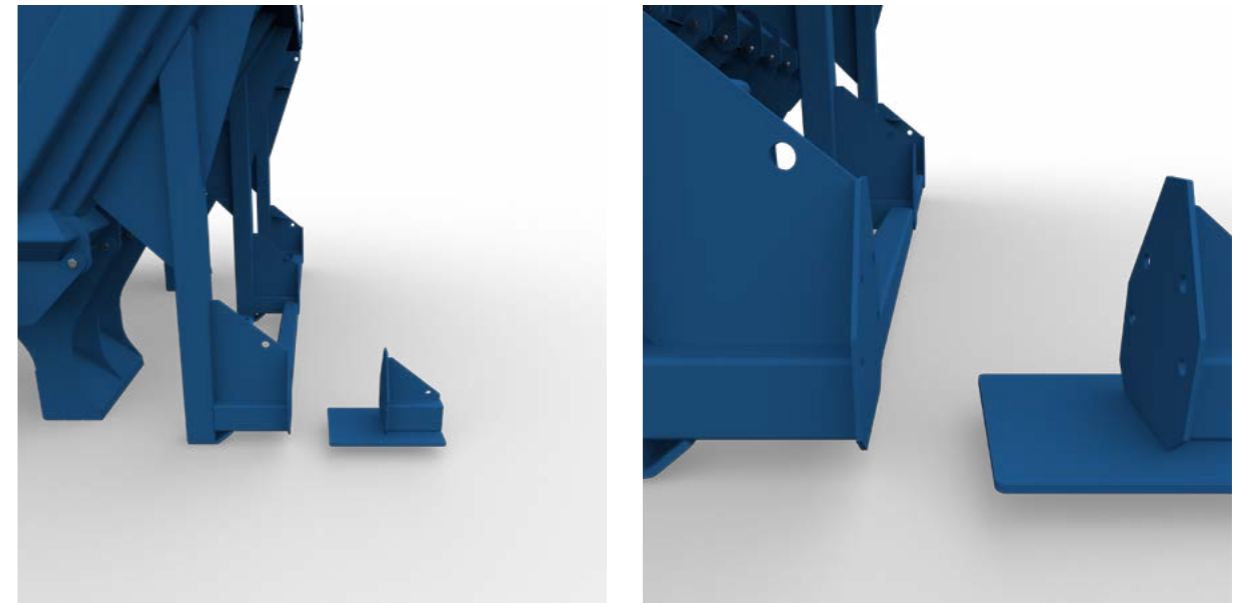

02. Fit one M16 x 60 bolt with a flat washer and insert through one of the aligned holes. Fit another flat washer to the bolt and add a nyloc nut.

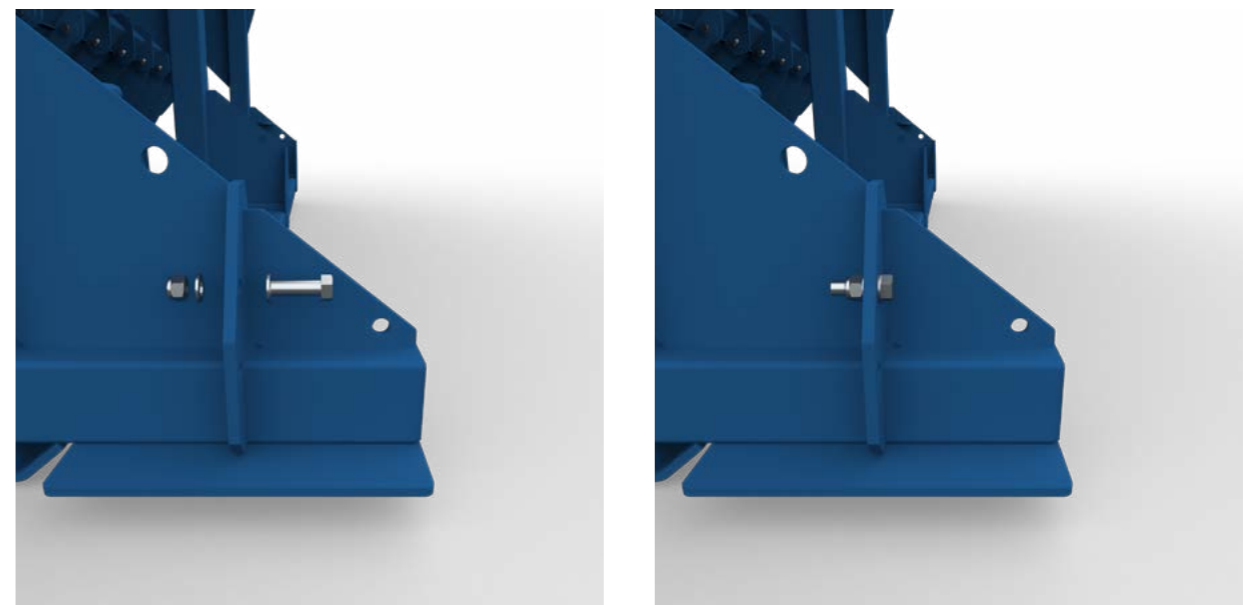

03. Whilst this is loosely fitted, align the next three M16 x 60 bolts in the extension bracket to the leg extension using the flat washers and nuts provided.

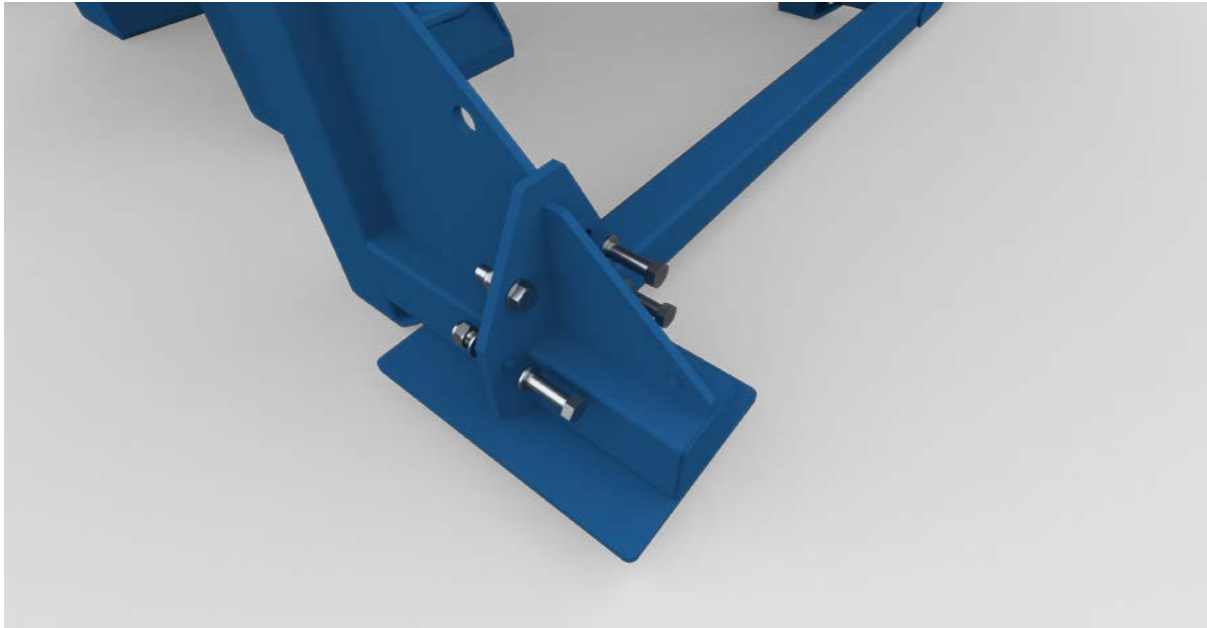

04. Repeat this process for the remaining leg extensions, hand tightening the M16 nuts and bolts.

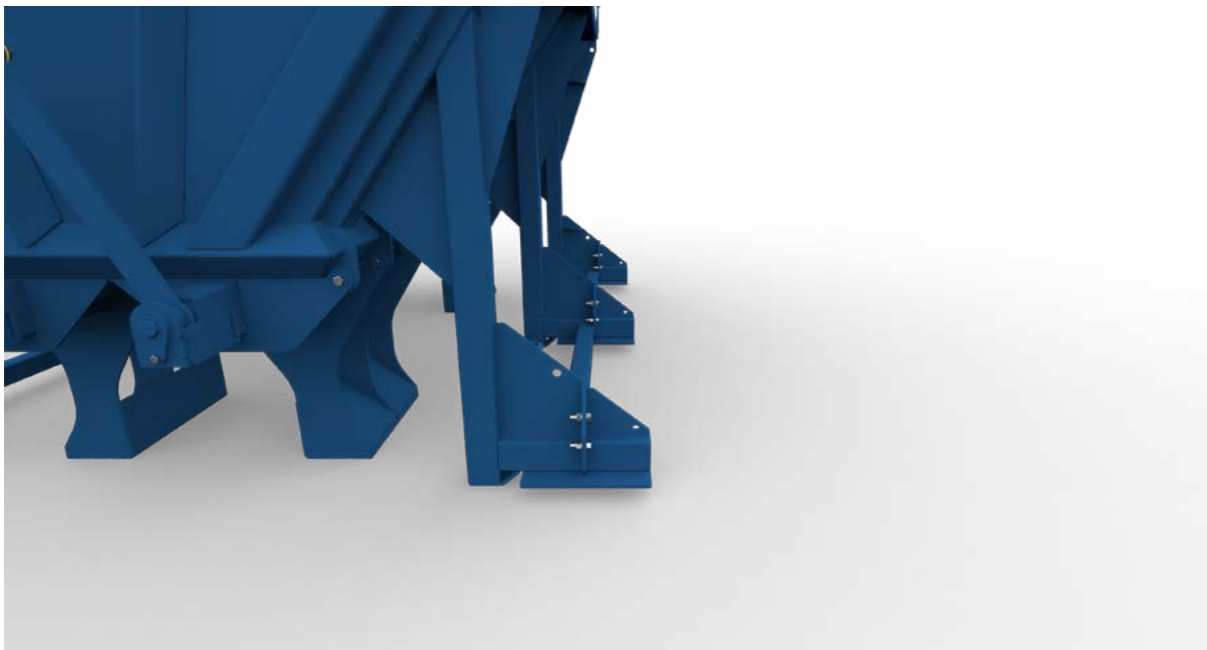

05. Then torque all M16 nuts and bolts to 200Nm. The BulkX bin is now ready to use.

LOADING THE BIN

01. Position the unit on firm level ground, which is able to bear the unit's weight and load.
02. The banksman must ensure the crane driver places the spreader beam to one side of the bin so it can be loaded without obstruction.



03. You can now evenly fill the bin, ensuring the load is no wider, longer or higher than the side walls of the bin.



MOVING & EMPTYING PROCEDURE

- 01. Once loaded, check that no spillage from the loading process has remained on the bin's sides. The bin's frame is purposely designed to be angled to reduce build up of overspill, however, it is advisable to have a stiff broom or similar to remove any remaining spoil on the sides of the bin before lifting.
- 02. Ensure tag lines are attached to the bin before lifting the bin from the fill area.

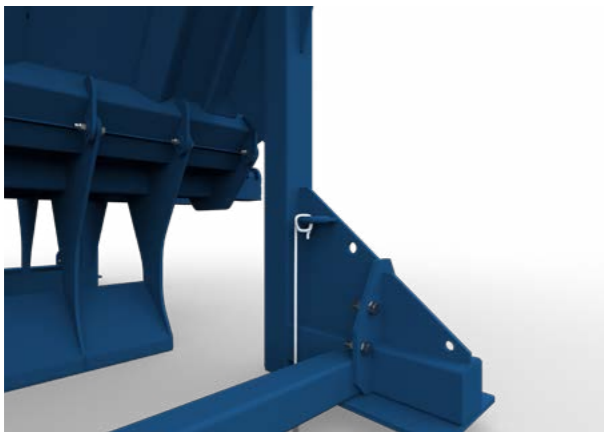

- 03. Clear all personnel from the immediate area, raise the bin just enough to allow sufficient clearance from the ground to check that the load is balanced.
- 04. DO NOT enter the area or allow anyone beneath the suspended load.
- 05. You can now crane lift the bin to the discharge area. Move the bin slowly to prevent it from swinging.
- 06. Lower the bin to allow operatives on the ground to reach the tag lines. Then guide the bin towards the truck.



- 07. Ensure the lifting chains are vertical, then slowly lower the bin so that it can dock with the truck, with the 'feet' of the bin resting evenly on each side of the truck. Ensure the crane operator does not lower the chains to the point where the doors will open.



- 08. Check all four feet of the bin are landed completely on the back of the truck. Then remove everyone from the discharge area and warn those around that the bin is about to be emptied.

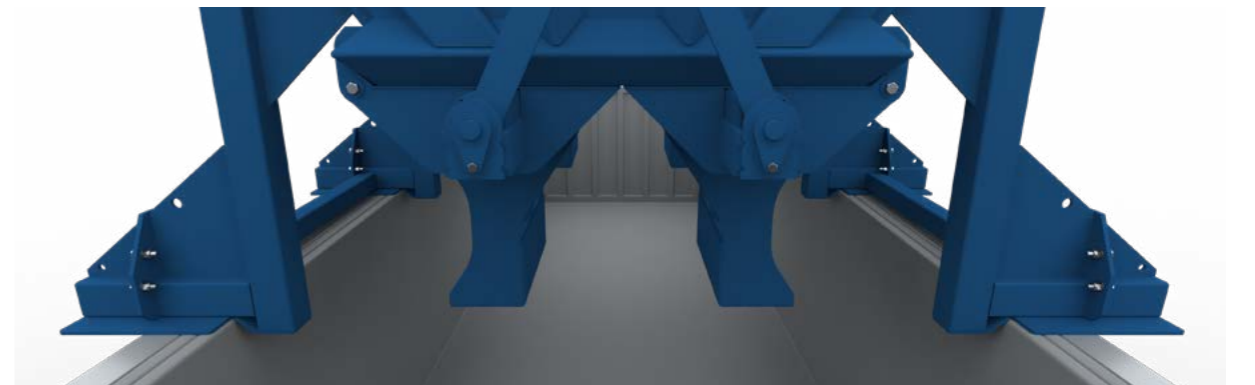

- 09. The crane operator lowers the chains, prompting the doors to open and the bin to discharge into the back of the truck.



- 10. Once empty, the bin can be lifted back to the loading area to refill and begin the process again.

MAINTENANCE & INSPECTION

MAINTENANCE REGIME

- It is mandatory that the equipment is thoroughly examined regularly, by a qualified engineer, to ensure compliance with relevant regulations. Conquip recommend carrying out a thorough examination every six months.
- This equipment may incorporate various loose and detachable items including, but not limited to pins, bolt assemblies and adaption plates. Refer to the separate requirements for the safe use of those items.
- When not being used, store the unit in a clean, upright condition and in a safe place where it will be protected from thieves and unauthorised users.
- This equipment must be inspected by the responsible person before each use and then regularly, as determined by your risk assessment or working practice. If you have any concerns about the equipment's condition or suitability, do not use it.



VISUAL INSPECTION CHECKLIST

INSPECTION ITEMS	RESULTS		COMMENTS
	SATISFACTORY	UNSATISFACTORY	
Serial Number			CQ.....
Product Code			
Working Load Limit (kg)			
Conforms to user guide specification			
(1) Inspect condition of lifting attachments			
(2) Check chain guide for wear or distortion			
(3) Check leg extensions ('feet') for wear or distortion			
(4) Check leg extensions ('feet') are secure			
(5) Check doors for wear or distortion			
Check door operation			
(6) Check door hinge bolts for security			
(7) Check spreader beam for bends or distortion			
General visual inspection of bin body			
SIGNATURE			
Name	Position	Qualification	Signature & Date

GENERAL SAFETY INSTRUCTIONS

The machinery should be properly operated and maintained to keep it in a safe, efficient operating condition. Be sure that all fixings and components are free of mud or other matter that might cause issues hazardous to the operator, serviceman, or other personnel or equipment. Report all malfunctions to those responsible for maintenance, and do not operate the equipment until corrected. Normal service or maintenance performed as required can prevent unexpected and unnecessary downtime.

This operations manual describes general inspections, servicing and operation with the normal safety precautions required for normal servicing and operating conditions. It is not a guide, however, for abnormal conditions or situations, and therefore, servicemen and operators must be safety conscious and alert to recognise potential servicing or operating safety hazards at all times, and take necessary precautions to assure safe servicing and operation of the machine.



M002
Refer to instructions manual



M004
Wear eye protection



M008
Wear safety footwear



M009
Wear protective gloves



M010
Wear protective clothing



M014
Wear head protection



M015
Wear high-visibility clothing

GENERAL NOTES

- Read this operations manual and learn the operating characteristics and limitations of the machinery. Know what operating clearances the machine requires.
- Read and understand all the safety signs prior to operation.
- If the safety signs are obstructed by dirt or debris, clean them using mild soap and water prior to operation.
- If the safety signs are damaged or illegible, replace them immediately, prior to operation.
- Be aware of operating hazards that weather changes can create on the job. Know proper procedures to follow when a severe rain or electrical storm strikes.
- Never attempt to operate or work on machinery when not feeling physically fit.
- Never wear loose clothing, rings, watches, heavy gloves etc., that might catch and result in injury.
- Know what safety equipment is required and use it. Such equipment may be: hard hat, safety glasses, reflector type vests, protective gloves and safety footwear.

TERMS & CONDITIONS

CONQUIP ENGINEERING GROUP STANDARD PRODUCT WARRANTY

01. COMMENCEMENT

1.1 This Warranty shall commence on the Commencement Date and shall continue until the earlier of:

- (a) the Expiry Date; or
- (b) the date on which it may be voided in accordance with clause 4.1(b)

when it shall terminate automatically without notice.

02. DUTY OF GOOD FAITH

2.1 The Purchaser shall in the exercise of its rights under this Warranty and in the compliance with its obligations under this Warranty be subject to and shall in all respects owe and comply with a duty of good faith to the Warrantor.

03. NATURE AND EXTENT OF COVER

3.1 Subject to clause 3.2 the Warrantor agrees and undertakes to the Purchaser that it shall be liable to the Purchaser under and in accordance with the terms of this Warranty in the event that:

- (a) prior to the Expiry Date the Purchaser shall notify a Warranty Claim to the Warrantor; and
- (b) the Equipment or any relevant part of the Equipment shall have become unusable as the result of defective material or defective workmanship prior to the Expiry Date.

3.2 The Warrantor's obligation under clause 3.1 shall be expressly subject to the provisions of clauses 4, 5 and 6 and conditional upon the Purchaser's compliance in full with the provisions of clause 7.

04. RESTRICTIONS

4.1 The following restrictions apply to this Warranty:

(a) This Warranty is personal to the Purchaser and neither the legal benefit nor legal burden of this warranty may be assigned or novated or otherwise transferred by the Purchaser to any other party. Any purported assignment, novation or transfer shall not be binding upon the Warrantor.

(b) This Warranty shall be void in the event that the Purchaser:

(i) cannot provide authentic and original documentary evidence that the Purchaser has during the period between the Commencement Date and the Expiry Date complied with the Maintenance and Servicing Requirements; and/or

(ii) has, during the period between the Commencement Date and the Expiry Date, exceeded the Purchaser's Usage Cycle Parameters; and/or

(iii) has, during the period between the Commencement Date and the Expiry Date, exceeded the Purchaser's Use Parameters; and/or

(iv) has carried out, or procured the carrying out by any third party of, any repair to the Equipment or any part of the Equipment which is not an Authorised Repair; and/or

(v) has operated the Equipment after having replaced any part of the Equipment with a part which has not been supplied and fitted by the Warrantor; and/or

(vi) has modified the Equipment in any way prior to use.

05. EXCLUSIONS

5.1 The following are excluded from the scope of this Warranty:

(a) Loss of and/ or damage to the Equipment or any part of it resulting from any collision between the Equipment and any other fixed or stationary or mobile object whatsoever, irrespective of whether that collision was or was not caused by the Purchaser; and/or

(b) Loss of and/or damage to any personal property and/or possessions or other equipment not forming part of the Equipment but which is present in or about the Equipment; and/or

(c) loss and/or damage which is covered by any other insurance policy taken out and maintained by the Purchaser or in respect of which the Purchaser has a contractual obligation to do so; and/or

(d) loss and/or damage to the equipment which is consistent with the use by the Purchaser of the Equipment:

(i) in compliance with the Maintenance and Servicing Requirements; and

(ii) in compliance with the Usage Cycle Parameters; and

(iii) in compliance with the Use Parameters; and

(iv) having only carried out Authorised Repairs to the Equipment; and

(v) having all and any replacement parts fitted by the Warrantor; and

(vi) in unmodified form.

06. LIMITATION OF LIABILITY

6.1 The Warrantor's liability to the Purchaser shall be limited as follows:

- (a) The Warrantor shall not in any circumstances be liable to the Purchaser for indirect and/or consequential and/or economic loss suffered and/or incurred as the case may be by the Purchaser; and
- (b) The Warrantor shall only be liable to the Purchaser for the reasonable and proper costs reasonably and properly incurred by the Purchaser directly in connection with the repair and/or replacement (at the Warrantor's absolute discretion) of the Equipment or any part of the Equipment; and
- (c) The Warrantor's liability to the Purchaser shall notwithstanding any other provision of this Warranty, not in any circumstances exceed the Purchase Price of the Equipment.

07. WARRANTY CLAIMS

7.1 The Purchaser shall in respect of any claim against the Warrantor under this Warranty and within 24 hours of the occurrence of the subject matter of the Warranty Claim:

- (a) Complete in full and submit to the Warrantor a Warranty Claim in the form annexed to Schedule 4;
- (b) Provide date stamped or date identifiable photographs evidencing the claim; and
- (c) Make the Equipment or the relevant part of the Equipment available to the Warrantor for inspection within 48 hours of notification of the relevant Warranty Claim.

08. ENTIRE AGREEMENT

8.1 This Warranty constitutes the entire agreement between the parties and supersedes and extinguishes all previous promises, assurances, warranties, representations and understandings between them, whether written or oral, relating to its subject matter.

8.2 Each party agrees that it shall have no remedies in respect of any statement, representation, assurance or warranty (whether made innocently or negligently) that is not set out in this Warranty. Each party agrees that it shall have no claim for innocent or negligent misrepresentation or negligent misstatement based on any statement in this Warranty.

No variation of this Warranty shall be effective unless it is in writing and signed by the parties (or their authorised representatives).

09. WAIVER

No failure or delay by a party to exercise any right or remedy provided under this Warranty or by law shall constitute a waiver of that or any other right or remedy, nor shall it prevent or restrict the further exercise of that or any other right or remedy. No single or partial exercise of such right or remedy shall prevent or restrict the further exercise of that or any other right or remedy.

10. SEVERANCE

10.1 If any provision or part-provision of this Warranty is or becomes invalid, illegal or unenforceable, it shall be deemed deleted, but that shall not affect the validity and enforceability of the rest of this Warranty.

10.2 If any provision or part-provision of this Warranty is deemed deleted under clause 10.1 the parties shall negotiate in good faith to agree a replacement provision that, to the greatest extent possible, achieves the intended commercial result of the original provision.

11. THIRD PARTY RIGHTS

11.1 This Warranty does not give rise to any rights under the Contracts (Rights of Third Parties) Act 1999 to enforce any term of this Warranty.

12. GOVERNING LAW

12.1 This Warranty and any dispute or claim (including non-contractual disputes or claims) arising out of or in connection with it or its subject matter or formation shall be governed by and construed in accordance with the law of England and Wales.

13. JURISDICTION

13.1 Each party irrevocably agrees that the courts of England and Wales shall have exclusive jurisdiction to settle any dispute or claim (including non-contractual disputes or claims) arising out of or in connection with this Warranty or its subject matter or formation.

DESIGN CONFORMITY (EC & UK)

- (01) This certificate meets the requirements of the Machinery Directive 2023/42/EC of the European Parliament and Council.
- (02) This certificate meets the requirements of the Supply of Machinery (Safety) Regulations 2008.

DETAILS

NAME & ADDRESS OF MANUFACTURER:
Conquip Engineering Group Ltd, Unit 4, Waterbrook Estate, Alton, Hampshire. GU34 2UD
NAME & ADDRESS OF PERSON TO COMPILE TECHNICAL FILE:
Name: Daniel Critchley Address: Conquip Engineering Group, Unit 4, Waterbrook Estate, Alton, Hampshire. GU34 2UD
NAME & ADDRESS OF AUTHORISED REPRESENTATIVE IF ONE HAS BEEN MANDATED BY THE MANUFACTURER:
N/A
NAME, ADDRESS, AND IDENTIFICATION NUMBER OF THE NOTIFIED BODY (01) OR APPROVED BODY (02), WHERE APPLICABLE:
N/A

EQUIPMENT DESCRIPTION

PRODUCT CODES	GENERAL DESCRIPTION / DESIGNATION	WORKING LOAD LIMIT
CA525-03000	Direct-To-Truck 3000	6000kg
CA525-04000	Direct-To-Truck 4000	8000kg
CA525-06000	Direct-To-Truck 6000	12000kg
CA525-08000	Direct-To-Truck 8000	16000kg

HARMONISED STANDARDS & REGULATIONS

ITEM	CODE	DESCRIPTION
EC DIRECTIVE / REGULATION	2023/42/EC	Directive 2023/42/EC- new machinery directive
HARMONISED STANDARDS	BS EN ISO 12100:2010	Safety of machinery General principles for design Risk assessment and risk reduction
	BS EN 1993-1-1: 2005	Eurocode 3. Design of steel structures General rules and rules for buildings
OTHER REGULATIONS	LOLER 1998	Lifting Operations and Lifting Equipment Regulations 1998 (LOLER)
	PUWER 1998	Provision and Use of Work Equipment Regulations 1998 (PUWER)

DECLARATION

PLACE OF DECLARATION:
Alton
DATE OF DECLARATION:
March 2026

I declare that the above equipment meets the Essential Health and Safety requirements of the
 (01) Machinery Directive 2023/42/EC of the European Parliament and Council.
 (02) Supply of Machinery (Safety) Regulations 2008 and Section 6 of the Health and Safety at Work Etc. Act 1974.

NAME:	POSITION:	SIGNATURE:
Daniel Critchley	Chief Executive Officer	

TALKING TO US IS EASY
WE'RE HERE TO HELP

Call us on (02) 8844 4590
Email us at sales@conquipgroup.com.au
www.cqegroup.com/au

