

User Guide

Fork Extensions

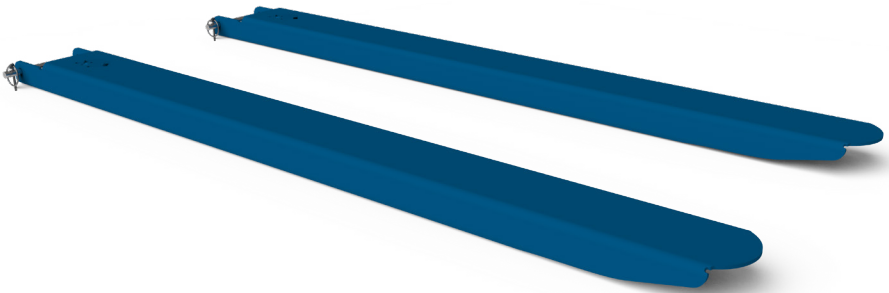

Product Information

Overview

The Conquip Fork Extensions provide a simple and effective solution for the need to stabilise long and awkward loads. The fork extensions increase the versatility of your forklift or telehandler, and fit standard sized forks.

Key Benefits

- Easy and simple to fit to forklift using heel pins.
- Other bespoke sizes can be available.
- Manufactured in the UK from quality British and EU steel.

Product Information

Specification

Item	Product Code
Fork Extensions 1500	FA808-01500
Fork Extensions 1800	FA808-01800
Fork Extensions 2400	FA808-02400

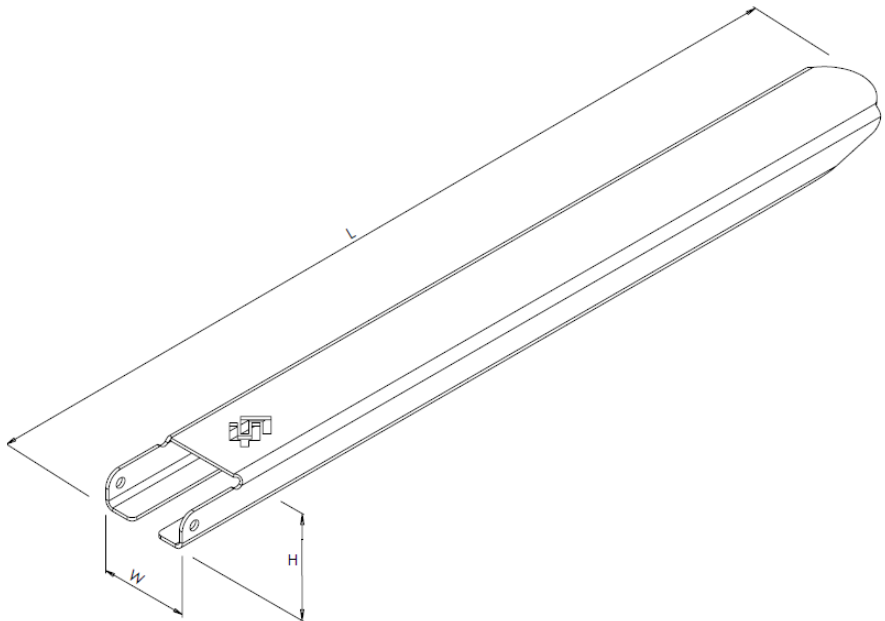

¹Working Load Limit

Product Code	Height	Width	Length	Weight (Per Fork)	WLL ¹ (Per Pair)	Fork Pocket
FA808-01500	72mm	160mm	1500mm	24kg	1000kg	148 x 60mm
FA808-01800	72mm	160mm	1800mm	28kg	1000kg	148 x 60mm
FA808-02400	72mm	160mm	2400mm	38kg	1000kg	148 x 60mm

Product Information

Parts Diagram

Fork Extensions

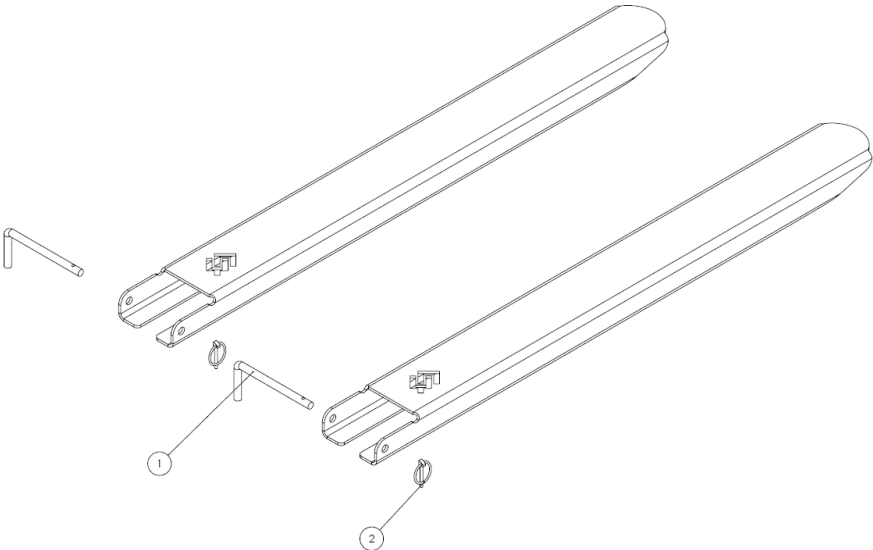

NOTE: These parts are for this model, they may differ for previous versions. Please contact Conquip with any queries.

Item Number	Part Number	Description	Quantity
1	ZZ990000	16mm Heel Pin	2
2	ZZ990009	6mm Linch Pin	2

Original Working Instructions

Usage Instructions

Important Usage Notes

- The Working Load Limit is NOT 1000kg for each Fork Extension, it is for the pair.
- DO NOT use this equipment to carry, transport or raise personnel.
- The Fork Extensions are retained on the forklift's forks by heel pins. The pins must be used and correctly fitted. If one or more are damaged, incomplete or missing do not use the equipment or any form of alternative. Contact Conquip Engineering Group for a replacement.
- The lifting capacity of the unit is governed by its extended length and by the load's centre of gravity. Ensure that the Fork Extensions are fully inserted into the load to ensure that the Fork Extensions are not overloaded.
- The Fork Extensions makes the forklift a longer vehicle and will require a larger area when turning. Also, when turning, the tip of the extensions will travel at a greater speed than normal. Excess weight on the tip of the extensions will make the forklift less stable and liable (in extreme cases) to tip forward. Where possible, drive forward up hill and backward downhill.

Using with a Forklift

1. To attach the Fork Extensions to a forklift, first release the heel pin by removing the lynch pin and pulling from the attachment. Set the machine's forks to the correct width for the Fork Extensions fork pockets. Make sure that they are equidistant from the centre.
2. Drive the forklift to the Fork Extensions aligning the forks with the Fork Extensions fork pockets.
3. Double check that all is correctly aligned, then move the forklift forward until the forks are fully inserted into the fork pockets.
4. Apply the park brake and switch off the forklift engine.
5. Insert the heel pin ensuring it passes behind the heel of the fork, use the lynch pin to lock the heel pin in place. The Fork Extensions are now ready for use.
6. Lifting, manoeuvring and lowering a load should be performed in the same way as with a standard fork length.
7. With the forklift extensions free of any load, lower it to the ground. Disconnect the heel pins. Drive the forklift back and clear then replace the heel pins and lynch pins.

Original Working Instructions

Safety Instructions

Basic Safety

A site-specific Risk Assessment, and lift plan where applicable, must be completed by the responsible person before using this equipment to control risks, produce a safe system of work and ensure safety for you, your colleagues and others. Your risk assessment will determine the correct Personal Protective Equipment (PPE) for the task you are doing. You must use it. Conquip recommends that you should wear:

- Suitable clothing
- Gloves
- Hard hat
- Protective footwear (steel toecaps)
- Safety glasses



Important Safety Notes

- Read these instructions before using this equipment. If there is anything you do not understand or if you have any concerns do not use this equipment. Contact your supervisor or Conquip Engineering Group for advice.
- You must check that you have considered all the safety requirements for the task you are doing and that this equipment is suitable.
- You must protect bystanders and the general public by preventing access to the working area.
- Do not use this equipment if you are tired, unwell or under the influence of alcohol or drugs. If you are taking any medicine or undergoing treatment you should inform your supervisor.

Usage & Transportation

- Never unevenly load this equipment.
- The weight of the equipment, together with its attachments, must be added to the weight of the load when calculating the total load that will be imposed on the lifting apparatus / operating machine.
- This equipment must be used in conjunction with the load ratings of the lifting apparatus / operating machine. (Refer to the manufacturers' load ratings and original working instructions).
- Make sure you know how to use this equipment and understand all aspects of its operation in case of emergency.
- This equipment weighs more than 20kg. Do not lift or manhandle without machine assistance.
- Do not operate this equipment near overhead power lines.
- Take care in confined spaces, near ceilings or similar hazards. This equipment was designed for vertical lifting. Do not drag, or swing.
- Before operating this equipment, check that you have enough space for you to work safely and make sure that the working area is clear of hazards, obstructions and personnel.
- Before lowering equipment make sure that the landing zone is clear and capable of accepting the size and weight of the load.
- Crush Risk. Keep hands and feet clear of the equipment at all times to avoid injury.
- Do not exceed the maximum Working Load Limit (WLL) shown on the serial plate. Ensure that the WLL on the individual lift points is not exceeded.
- Before lifting, check that the load is secured, balanced and stable. Allow space for the equipment to move if the load shifts.
- Manoeuvre loaded or raised equipment carefully. Travel and turn slowly to avoid unit becoming unstable.

Personnel

- All personnel must wear relevant personal protective equipment.
- Do not wear loose clothing or jewellery and tie back long hair to avoid becoming tangled or trapped in this equipment. You must make everyone in the work area aware of what you are doing.
- All personnel involved in the lifting operation must be competent to do so and must have been briefed in conjunction with this User Guide available from Conquip Engineering Group, the manufacturer.

Equipment Maintenance & Cleaning

- It is mandatory that the equipment is thoroughly examined regularly, by a qualified engineer, to ensure compliance with relevant regulation/s. (Conquip recommend to carry out thorough examination every six months).
- This product may incorporate various loose and detachable items of lifting gear. Refer to the separate requirements for the safe use of those items.
- When not being used, store the unit in a clean, upright condition and in a safe place where it will be protected from thieves and unauthorised users.
- This equipment must be inspected by the responsible person before each use and then regularly, as determined by your risk assessment or working practice. If you have any concerns about condition or suitability do not use.

Disclaimer

Warranty

The products supplied by Conquip Engineering Group are all guaranteed by a 12 month warranty.

Apart from where exceptions apply, Conquip Engineering Group promises to repair or replace any fault which the Company considers to be due to defective material or workmanship within 12 months of the date of sale, at no additional cost.

- Faults arising from unauthorised alterations (see modifications section below for full details).
- Damage caused by abuse, neglect, misuse or falling.
- Damage caused because of failure to follow transportation, storage, loading, cleaning or operating instructions.
- Replacement or repair of components due to fair wear and tear.
- Any consequential damage or wear arising from the use or fitting of additional or non-standard parts.

Modifications

If any third-party modifications or alterations, involving drilling, welding, cutting or distortion of materials in any form, are to be carried out on the product, Conquip Engineering Group must provide full written approval prior to the work being carried out.

Alterations, modifications, additions or repairs must be carried out by Conquip Engineering Group's recognised distributors, if they are not carrying out the work themselves.

Conquip Engineering Group operate a continuous improvement policy and therefore reserve the right to alter technical specifications and user guide details at any point without notice.

Conquip Engineering Group will not cover or reimburse any transportation and/or shipment costs to and from their premises or their recognised agents, or any material and/or labour costs for repair, replacement or assessment against a warranty claim.

Conquip Engineering Group and/or their directors, employees, insurers or recognised agents will not be held liable for consequential damages, losses or expenses relating to the inability to use the product correctly for its purpose.

Important Notes

- This User Guide is for this Conquip product only.
- Any movements of the product must be thoroughly planned before the work commences to identify potential hazards and assess risk.
- All personnel involved in lifting and transportation of this product must have read this User Guide and must be properly briefed.
- You must be competent, alert and medically fit when using this equipment. If you have a medical condition, a mental or physical disability, you must seek advice from a medical professional before using this equipment.

Talking to us is easy

We're here to help

Call us on (02) 8844 4590

Email us at sales@conquipgroup.com.au

www.conquipgroup.com.au