

User Guide

# Kerb Lifter



## Product Information

### **Overview**

---

The Conquip Kerb Lifter is an automatic load and release kerb lifter, designed for safe handling of kerbs, steps and other preformed sections. It can be machine lifted by crane or other suitable lifting apparatus, by a central lifting point, or manually lifted by the handles.

### **Key Benefits**

- Easily adjusted by means of a locating pin.
- Automatic load and release mechanism for quick and easy material movement.
- Manufactured in the UK from quality British and EU steel.

# Product Information

## Specification

Item	Product Code
Kerb Lifting	MH701AA-00600

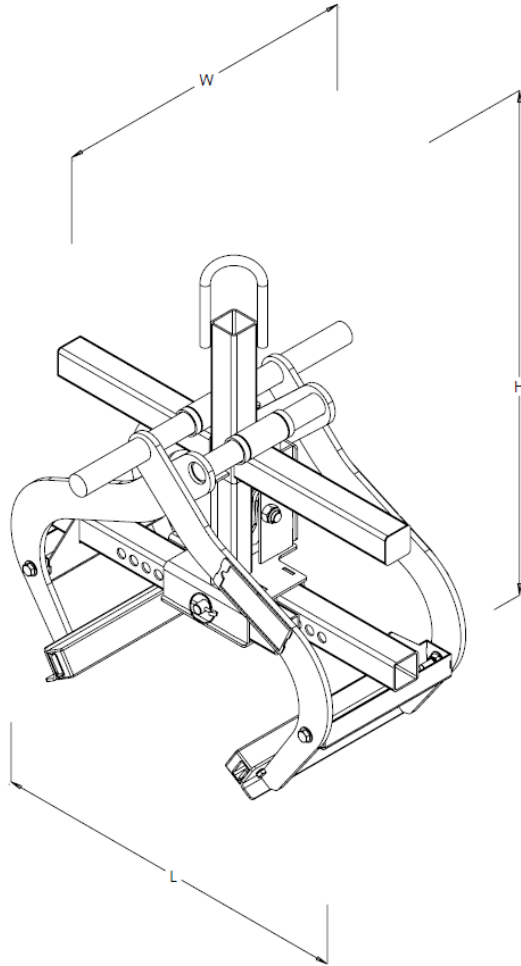

<sup>1</sup>Working Load Limit

Height (Extended)	Height (At Rest)	Width	Length	Weight	WLL <sup>1</sup>	Grip Range
775mm	600mm	550mm	675mm	34kg	600kg	50- 600mm

# Product Information

## Parts Diagram

### Kerb Lifter

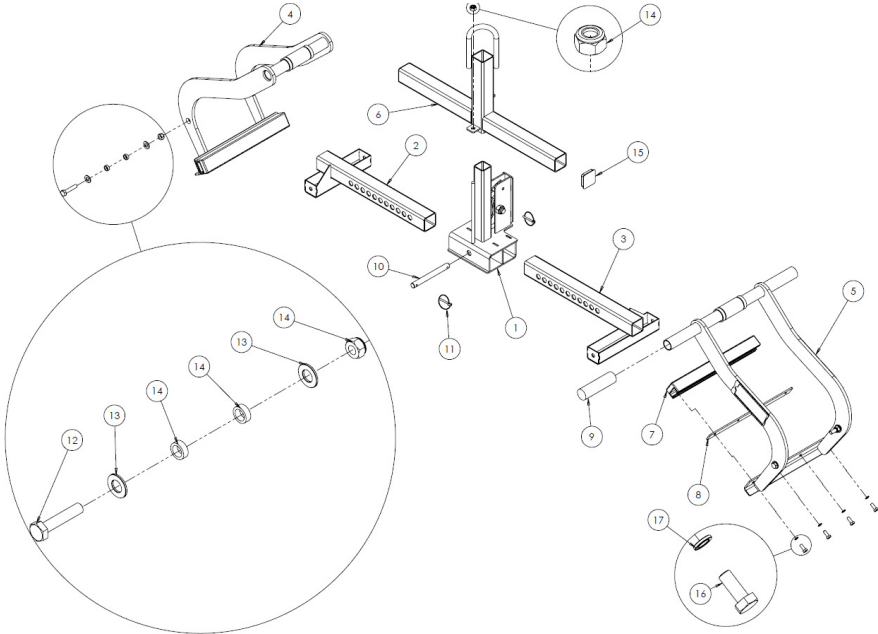

# Product Information

## Parts Diagram

---

### Kerb Lifter

NOTE: These parts are for this model, they may differ for previous versions. Please contact Conquip with any queries.

Item Number	Part Number	Description	Quantity
1		Lifting T Piece	1
2		Gripper Width Adjuster	1
3		Gripper Width Adjuster Small	1
4		Short Arm Handle	1
5		Long Arm Handle	1
6		Lifting T Piece	1
7		Rubber Buffer	2
8		Rubber Grip Mounting Plate	2
9		Rubber Handle	2
10		Locating Pin	1
11	ZZ990009	Linch Pin 5.5mm	2
12	NS800828	M10 x 50 Socket Head Set Screw	4
13	NS800262	M10 Washer	8
14		Arm Spacer	8
15		Plastic End Cap	2
16	NS800160	M8 x 20 Hex Head Set Screw	8
17	NS800378	M8 Spring Washer	8

# Original Working Instructions

## Usage Instructions

---

### Important Usage Notes

- Carry out a manual handling assessment before use.
- Do not lift if not comfortable with load weight.
- The Kerb Lifter relies upon a 'crushing' force to grip the load prior to and during the lift. You should inspect each load prior to lifting to ensure its suitability and prevent load damage.
- Do not allow hands or feet to come between or below the lifter and the load.
- Do not attempt to adjust or manhandle a load whilst it is in a raised position.
- The lifters grips should not be in contact with the ground. When lifting blocks, the lifter's grips should be no higher than 1/3 up the block.
- Always try to lift the material end on rather than the sides.
- The load's length must not be greater than the lifter's arms.
- Do not drag the load; this equipment is for lifting the load clear of the ground.
- Ensure the Kerb Lifter is kept at a sensible height and is guided by a slinger/signaller at all times to avoid personnel injury.
- Ensure the destination of the kerbs/load is stable and firm, and can take the load of the materials and the Kerb Lifter.
- Do not try and attempt to lift multiple kerbs at one time.

### Preparing the Kerb Lifter

1. Take the Kerb Lifter to the material and adjust the grip faces to suit the length of the load.
2. Adjustment is achieved by removing the linch pin and locating pin and sliding the grip faces together or apart, as required, as close to the length of the materials as possible.
3. Replace locating pin and linch pin.

# Original Working Instructions

## Usage Instructions

---

### Crane Lifting

1. Attach a suitably rated lifting chain to the crane or other suitable lifting apparatus.
2. Attach the chain to the lifting point at the top of the Kerb Lifter. Always ensure that the hook's gate is correctly closed.
3. Raise the lifter and position over the load, checking that it is centrally aligned before lowering.
4. Lower the lifter and position the grip faces against each end of the material.
5. Carefully raise the load just off the ground and check for balance and security.
6. Carefully transport the load to its required destination, taking care not to jolt the load.
7. When in position, lower the load until in contact with the ground. The lifter's grips will automatically release and allow you to raise the Kerb Lifter clear of the load.
8. You can now proceed to the next load, or lower the Kerb Lifter to the ground and unattach from the lifting chain and lifting apparatus.
9. An unloaded lifter will alter between grip and release each time it receives a jolt.
10. This may cause the jaws to be out of sync when you next attempt to 'grab a load'.
11. If this is the case, lower the empty Kerb Lifter to the ground to alter to the release position before reloading.

# Original Working Instructions

## Safety Instructions

---

### Basic Safety

A site-specific Risk Assessment, and lift plan where applicable, must be completed by the responsible person before using this equipment to control risks, produce a safe system of work and ensure safety for you, your colleagues and others. Your risk assessment will determine the correct Personal Protective Equipment (PPE) for the task you are doing. You must use it. Conquip recommends that you should wear:

- Suitable clothing
- Gloves
- Hard hat
- Protective footwear (steel toecaps)
- Safety glasses



### Important Safety Notes

- Read these instructions before using this equipment. If there is anything you do not understand or if you have any concerns do not use this equipment. Contact your supervisor or Conquip Engineering Group for advice.
- You must check that you have considered all the safety requirements for the task you are doing and that this equipment is suitable.
- You must protect bystanders and the general public by preventing access to the working area.
- Do not use this equipment if you are tired, unwell or under the influence of alcohol or drugs. If you are taking any medicine or undergoing treatment you should inform your supervisor.



## Usage & Transportation

- Never unevenly load this equipment.
- The weight of the equipment, together with its attachments, must be added to the weight of the load when calculating the total load that will be imposed on the lifting apparatus / operating machine.
- This equipment must be used in conjunction with the load ratings of the lifting apparatus / operating machine. (Refer to the manufacturers' load ratings and original working instructions).
- Make sure you know how to use this equipment and understand all aspects of its operation in case of emergency.
- This equipment weighs more than 25kg. Do not lift or manhandle without machine assistance.
- Do not operate this equipment near overhead power lines.
- Take care in confined spaces, near ceilings or similar hazards. This equipment was designed for vertical lifting. Do not drag, or swing.
- Before operating this equipment, check that you have enough space for you to work safely and make sure that the working area is clear of hazards, obstructions and personnel.
- Before lowering equipment make sure that the landing zone is clear and capable of accepting the size and weight of the load.
- Crush Risk. Keep hands and feet clear of the equipment at all times to avoid injury.
- Do not exceed the maximum Working Load Limit (WLL) shown on the serial plate. Ensure that the WLL on the individual lift points is not exceeded.
- Before lifting, check that the load is secured, balanced and stable. Allow space for the equipment to move if the load shifts.

## Personnel

- All personnel must wear relevant personal protective equipment.
- Do not wear loose clothing or jewellery and tie back long hair to avoid becoming tangled or trapped in this equipment. You must make everyone in the work area aware of what you are doing.
- All personnel involved in the lifting operation must be competent to do so and must have been briefed in conjunction with this User Guide available from Conquip Engineering Group, the manufacturer.

## Equipment Maintenance & Cleaning

- It is mandatory that the equipment is thoroughly examined regularly, by a qualified engineer, to ensure compliance with relevant regulation/s. (Conquip recommend to carry out thorough examination every six months).
- This product may incorporate various loose and detachable items of lifting gear. Refer to the separate requirements for the safe use of those items.
- When not being used, store the unit in a clean, upright condition and in a safe place where it will be protected from thieves and unauthorised users.
- This equipment must be inspected by the responsible person before each use and then regularly, as determined by your risk assessment or working practice. If you have any concerns about condition or suitability do not use.

# Disclaimer

---

## Warranty

The products supplied by Conquip Engineering Group are all guaranteed by a 12 month warranty.

Apart from where exceptions apply, Conquip Engineering Group promises to repair or replace any fault which the Company considers to be due to defective material or workmanship within 12 months of the date of sale, at no additional cost.

- Faults arising from unauthorised alterations (see modifications section below for full details).
- Damage caused by abuse, neglect, misuse or falling.
- Damage caused because of failure to follow transportation, storage, loading, cleaning or operating instructions.
- Replacement or repair of components due to fair wear and tear.
- Any consequential damage or wear arising from the use or fitting of additional or non-standard parts.

## Modifications

If any third-party modifications or alterations, involving drilling, welding, cutting or distortion of materials in any form, are to be carried out on the product, Conquip Engineering Group must provide full written approval prior to the work being carried out.

Alterations, modifications, additions or repairs must be carried out by Conquip Engineering Group's recognised distributors, if they are not carrying out the work themselves.

Conquip Engineering Group operate a continuous improvement policy and therefore reserve the right to alter technical specifications and user guide details at any point without notice.

Conquip Engineering Group will not cover or reimburse any transportation and/or shipment costs to and from their premises or their recognised agents, or any material and/or labour costs for repair, replacement or assessment against a warranty claim.

Conquip Engineering Group and/or their directors, employees, insurers or recognised agents will not be held liable for consequential damages, losses or expenses relating to the inability to use the product correctly for its purpose.



## Important Notes

- This User Guide is for this Conquip product only.
- Any movements of the product must be thoroughly planned before the work commences to identify potential hazards and assess risk.
- All personnel involved in lifting and transportation of this product must have read this User Guide and must be properly briefed.
- You must be competent, alert and medically fit when using this equipment. If you have a medical condition, a mental or physical disability, you must seek advice from a medical professional before using this equipment.

Talking to us is easy

**We're here to help**

Call us on (02) 8844 4590

Email us at [sales@conquipgroup.com.au](mailto:sales@conquipgroup.com.au)

[www.conquipgroup.com.au](http://www.conquipgroup.com.au)