

User Guide

Block Grab Forklift Adaptor

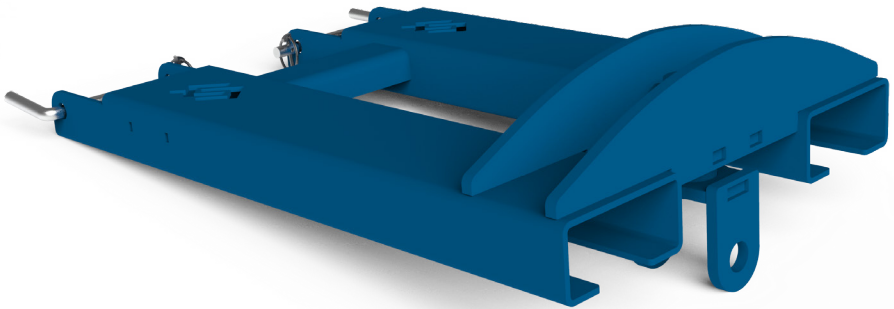

Product Information

Overview

The Conquip Block Grab Forklift Adaptor is a quick and easy method of adapting a Conquip Block Grab to be used with a forklift or telehandler to lift blocks and bricks.

Key Benefits

- Ideal for moving palletised blocks and bricks short distances around site.
- Reduces swing on the Block Grab.
- Easy to fit to a forklift using heel pins.

Product Information

Specification

Item	Product Code
Block Grab Forklift Adaptor	FA105AA-02000

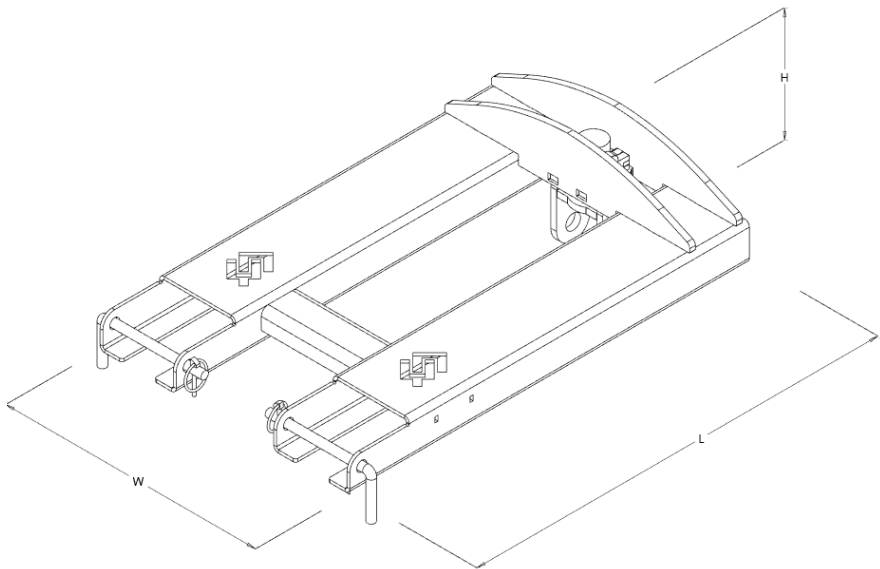

¹Working Load Limit

Height	Width	Length	Weight	WLL ¹
250mm	525mm	840mm	40kg	2000kg

Product Information

Parts Diagram

Block Grab Forklift Adaptor

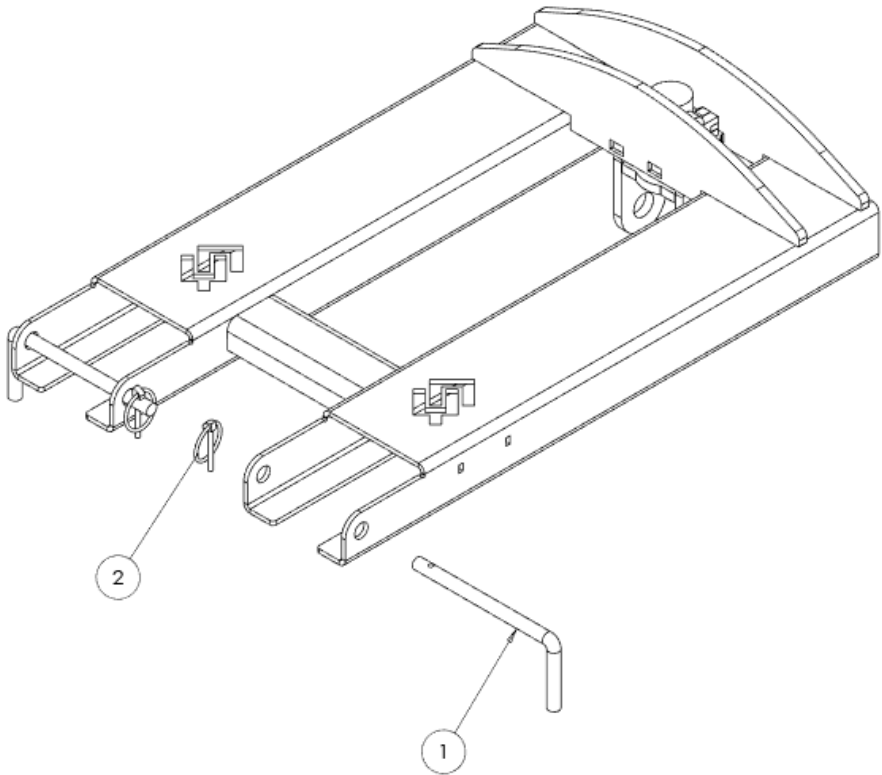

NOTE: These parts are for this model, they may differ for previous versions. Please contact Conquip with any queries.

Item Number	Part Number	Description	Quantity
1	ZZ990000	Heel Pin 16mm	2
2	ZZ990009	Linch Pin 6mm	2

Original Working Instructions

Usage Instructions

Important Usage Notes

- The Block Grab Forklift Adaptor is supplied with two heel pins, one for each fork pocket. These must both be fitted correctly before use. If one or more are damaged, incomplete or missing do not use the equipment, do not use alternatives- contact Conquip for a replacement.
- This equipment is designed to lift the load clear of the ground. Do not drag the load.

Using with a Forklift

1. To attach the Block Grab Forklift Adaptor to a forklift, first release the heel pin by removing the linch pin and pulling from the attachment. Set the machine's forks to the correct width for the Block Grab Forklift Adaptor fork pockets. Make sure that they are equidistant from the centre.
2. Drive the telehandler to the Block Grab Forklift Adaptor aligning the forks with the fork pockets.
3. Move the telehandler forward until the forks are fully inserted into the fork pockets.
4. Apply the park brake and switch off the forklift engine.
5. Insert the heel pin ensuring it passes behind the heel of the fork, use the linch pin to lock the heel pin in place. The Block Grab Forklift Adaptor is now ready to attach to the Block Grab.
6. Remove the Block Grab's lift point if fitted.
7. Raise and position the hook over the Block Grab's lifting point, ensuring that it is centrally aligned before lowering.
8. Lower into position and using the Block Grab's lifting pin. Secure in place with linch pin.
9. Carefully raise the Block Grab just off the ground and check for balance and security. Do not allow hands or feet to come between or below the grab.
10. Carefully transport the Block Grab to the blocks or bricks that are to be lifted.
11. Refer to the Conquip Block Grab User Guide to adjust and use the Block Grab correctly.

Original Working Instructions

Usage Instructions

Using with a Forklift Continued

12. Once the Block Grab Forklift Adaptor and Block Grab are no longer required and free of any load, lower the Block Grab to the ground.
13. Release the Block Grab from the lifting point on the forklift adaptor and reverse the forklift with adaptor still attached clear of the Block Grab.
14. Lower the Block Grab Forklift Adaptor to the ground.
15. Remove the heel pins and linch pins.
16. Reverse the forklift back and clear of the forklift adaptor.
17. Replace the heel pins and linch pins.

Forklift Adaptor Connected to Block Grab

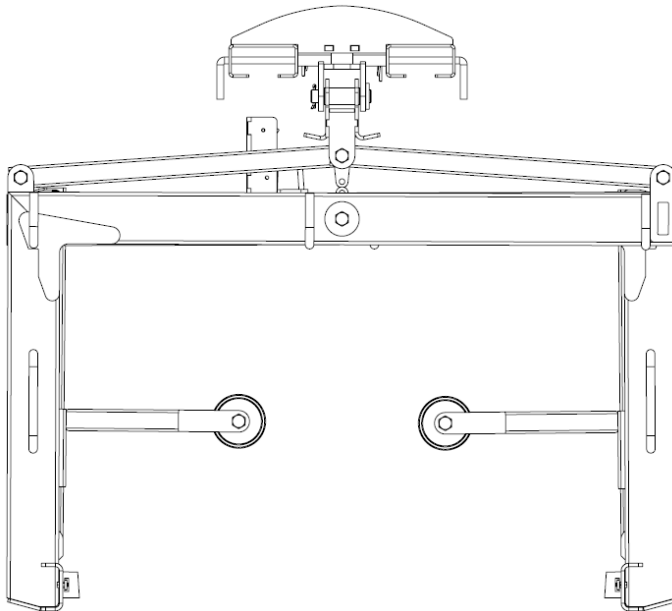

Original Working Instructions

Safety Instructions

Basic Safety

A site-specific Risk Assessment, and lift plan where applicable, must be completed by the responsible person before using this equipment to control risks, produce a safe system of work and ensure safety for you, your colleagues and others. Your risk assessment will determine the correct Personal Protective Equipment (PPE) for the task you are doing. You must use it. Conquip recommends that you should wear:

- Suitable clothing
- Gloves
- Hard hat
- Protective footwear (steel toecaps)
- Safety glasses



Important Safety Notes

- Read these instructions before using this equipment. If there is anything you do not understand or if you have any concerns do not use this equipment. Contact your supervisor or Conquip Engineering Group for advice.
- You must check that you have considered all the safety requirements for the task you are doing and that this equipment is suitable.
- You must protect bystanders and the general public by preventing access to the working area.
- Do not use this equipment if you are tired, unwell or under the influence of alcohol or drugs. If you are taking any medicine or undergoing treatment you should inform your supervisor.

Usage & Transportation

- Never unevenly load this equipment.
- The weight of the equipment, together with its attachments, must be added to the weight of the load when calculating the total load that will be imposed on the lifting apparatus / operating machine.
- This equipment must be used in conjunction with the load ratings of the lifting apparatus / operating machine. (Refer to the manufacturers' load ratings and original working instructions).
- Make sure you know how to use this equipment and understand all aspects of its operation in case of emergency.
- This equipment weighs more than 25kg. Do not lift or manhandle without machine assistance.
- Do not operate this equipment near overhead power lines.
- Take care in confined spaces, near ceilings or similar hazards. This equipment was designed for vertical lifting. Do not drag, or swing.
- Before operating this equipment, check that you have enough space for you to work safely and make sure that the working area is clear of hazards, obstructions and personnel.
- Before lowering equipment make sure that the landing zone is clear and capable of accepting the size and weight of the load.
- Crush Risk. Keep hands and feet clear of the equipment at all times to avoid injury.
- Do not exceed the maximum Working Load Limit (WLL) shown on the serial plate. Ensure that the WLL on the individual lift points is not exceeded.
- Before lifting, check that the load is secured, balanced and stable. Allow space for the equipment to move if the load shifts.
- Manoeuvre loaded or raised equipment carefully. Travel and turn slowly to avoid unit becoming unstable.

Personnel

- All personnel must wear relevant personal protective equipment.
- Do not wear loose clothing or jewellery and tie back long hair to avoid becoming tangled or trapped in this equipment. You must make everyone in the work area aware of what you are doing.
- All personnel involved in the lifting operation must be competent to do so and must have been briefed in conjunction with this User Guide available from Conquip Engineering Group, the manufacturer.

Equipment Maintenance & Cleaning

- It is mandatory that the equipment is thoroughly examined regularly, by a qualified engineer, to ensure compliance with relevant regulation/s. (Conquip recommend to carry out thorough examination every six months).
- This product may incorporate various loose and detachable items of lifting gear. Refer to the separate requirements for the safe use of those items.
- When not being used, store the unit in a clean, upright condition and in a safe place where it will be protected from thieves and unauthorised users.
- This equipment must be inspected by the responsible person before each use and then regularly, as determined by your risk assessment or working practice. If you have any concerns about condition or suitability do not use.

Disclaimer

Warranty

The products supplied by Conquip Engineering Group are all guaranteed by a 12 month warranty.

Apart from where exceptions apply, Conquip Engineering Group promises to repair or replace any fault which the Company considers to be due to defective material or workmanship within 12 months of the date of sale, at no additional cost.

- Faults arising from unauthorised alterations (see modifications section below for full details).
- Damage caused by abuse, neglect, misuse or falling.
- Damage caused because of failure to follow transportation, storage, loading, cleaning or operating instructions.
- Replacement or repair of components due to fair wear and tear.
- Any consequential damage or wear arising from the use or fitting of additional or non-standard parts.

Modifications

If any third-party modifications or alterations, involving drilling, welding, cutting or distortion of materials in any form, are to be carried out on the product, Conquip Engineering Group must provide full written approval prior to the work being carried out.

Alterations, modifications, additions or repairs must be carried out by Conquip Engineering Group's recognised distributors, if they are not carrying out the work themselves.

Conquip Engineering Group operate a continuous improvement policy and therefore reserve the right to alter technical specifications and user guide details at any point without notice.

Conquip Engineering Group will not cover or reimburse any transportation and/or shipment costs to and from their premises or their recognised agents, or any material and/or labour costs for repair, replacement or assessment against a warranty claim.

Conquip Engineering Group and/or their directors, employees, insurers or recognised agents will not be held liable for consequential damages, losses or expenses relating to the inability to use the product correctly for its purpose.

Important Notes

- This User Guide is for this Conquip product only.
- Any movements of the product must be thoroughly planned before the work commences to identify potential hazards and assess risk.
- All personnel involved in lifting and transportation of this product must have read this User Guide and must be properly briefed.
- You must be competent, alert and medically fit when using this equipment. If you have a medical condition, a mental or physical disability, you must seek advice from a medical professional before using this equipment.

Talking to us is easy

We're here to help

Call us on (02) 8844 4590

Email us at sales@conquipgroup.com.au

www.conquipgroup.com.au